



# County of Calaveras Department of Planning

---

**Bret Sampson ~ Planning Director**  
Phone (209) 754-6394 Fax (209) 754-6540  
**Website: <https://planning.calaverasgov.us>**

---

Date: March 19, 2025  
To: Planning Commission  
From: Madeleine Flandreau, Senior Planner  
Subject: Addendum to Staff Report  
2024-013 CUP for Jeremy and Lynette Smith-Covey dba 4 Horse Ranch

The purpose of this addendum is to provide the Commission with supplemental documentation for the 4 Horse Ranch CUP based on the Commission's request during the March 13, 2025, hearing. Please find in Attachment 1 to this addendum the amended draft Planning Commission Resolution 2025-004 which includes: the site plan in Exhibit A, the Mitigated Monitoring and Reporting Program in Exhibit B, the Mitigated Negative Declaration which includes the project description in Exhibit C, and the Final Waste Management Plan which has been approved by the Environmental Management Agency in Exhibit D. Attachment 2 to this addendum includes the applicant's draft Manure Management Plan. The Best Management Practices included in the Final Waste Management are taken from staff recommendations and *Horse Manure Management (A guide for Bay Area Horse Keepers)* Bay Area RCDs and *Horse Keeping: A Guide to Land Management for Clean Water. Bay Area RCDs* which are included as Attachments 3 and 4, respectively, to this addendum.

Based on the above documents, staff concludes that Mitigation Measure AQ-1 should remain unmodified and that no further mitigation need to be applied to this project and recommend the approval of the project as originally presented.

Attachment 1 –  
Draft Amended Planning Commission Resolution  
No. 2025-004

**COUNTY OF CALAVERAS, STATE OF CALIFORNIA  
PLANNING COMMISSION**

**RESOLUTION NO. 2025-004**

**>>A RESOLUTION ADOPTING THE MITIGATED NEGATIVE DECLARATION AND APPROVING CONDITIONAL USE PERMIT 2024-013 FOR LYNETTE AND JEREMY COVEY-SMITH DBA 4 HORSE RANCH TO OPERATE A PRIVATE EQUESTRIAN FACILITY IN THE RURAL RESIDENTIAL ZONE**

---

WHEREAS, the Planning Department of the County of Calaveras received an application from Jeremy and Lynette Covey-Smith requesting approval of a Conditional Use Permit to permit an existing private equestrian facility for up to 40 horses on a 20-acre Rural Residential parcel; and

WHEREAS, the Covey-Smith's complete application was received prior to the enactment of the current version of the Calaveras County Zoning Code (Title 17) enacted on August 15, 2024; and

WHEREAS, the Planning Commission considered the project request pursuant to the 2019 Calaveras County General Plan, the former version of the Zoning Code, and the procedures of the Planning Commission; and

WHEREAS, the proposed project is located on real property in the unincorporated portions of the County of Calaveras, more particularly described as APN 048-009-052 and located at 2911 Patriot Way in Burson, in Section 21, T04N, R10E, MDM; and

WHEREAS, an Initial Study and Negative Declaration was prepared and available for public review for 30 days, pursuant to the requirements of the California Environmental Quality Act, which adequately addressed the potentially significant impacts associated with the proposed project but inadvertently omitted one mitigation measure; and

WHEREAS, a revised Initial Study and Mitigated Negative Declaration was prepared and made available for public review for 30 days, pursuant to the requirements of the California Environmental Quality Act, which described the same potentially significant impacts but added the missing mitigation measure. The Mitigated Negative Declaration and Mitigation Monitoring and Reporting Program are attached and incorporated by reference as Exhibits B and C to the Resolution; and

WHEREAS, these CEQA documents were sent to applicable California Native American tribes as required by AB 52, and no requests to consult with the County were received; and

WHEREAS, all documents contained in the staff report and any addendum to the staff report, and all documents submitted by any party or member of the public for purposes of this hearing prior to its conclusion shall be incorporated by reference herein; and

WHEREAS, during a noticed public hearing on March 13<sup>th</sup>, 2025, the Planning Commission considered all of the information presented to it, including its staff report, CEQA documentation, information presented by the project proponent and public testimony presented at the meeting;

WHEREAS, having considered all such testimony on March 13<sup>th</sup>, 2025, the Planning Commission unanimously agreed to continue the item to the March 27<sup>th</sup>, 2025, for the purpose of amending the resolution and including the Manure Management Plan.

BE IT THEREFORE RESOLVED, that the Planning Commission adopts the Mitigated Negative Declaration and approves Conditional Use Permit 2024-013, based on the following findings:

### **CEQA Findings**

1. Based on the whole record, there is no substantial evidence that the project as designed and conditioned will have a significant effect on the environment. A Mitigated Negative Declaration has been prepared in accordance with the California Environmental Quality Act (CEQA). The Mitigated Negative Declaration reflects the independent judgment and analysis of the preparer.

**Evidence:** Pursuant to CEQA guidelines, County staff prepared an Initial Study and Negative Declaration (ISND), which was distributed for a 30-day review and comment period from September 11, 2024, to October 11, 2024. Two letters were received by staff from MyValleySprings.com, one from Colleen Platt and one from Joyce Techel. Comments included concerns regarding impacts to neighbors which were brought up during an enforcement-related appeal hearing with the Administrative Hearing Board, specifically the number of horses being kept on site. Concerns were also raised regarding the baseline in the ISND as being the existing business use of the property at the time the CUP permit was applied for.

As the subject parcel was already developed with the equestrian facility at the time the CUP application arose, with fenced pastures and an arena, the CEQA baseline is the conditions in place when the environmental analysis commenced—which included a developed parcel with fenced pastures and an arena. The applicant is not proposing to expand the use or develop more structures on the property. The project's operation would not change the condition of the Project site with respect to biological resources or habitat types. As all structures are already existing and the subject parcel is already disturbed, it is unlikely that special-status species would be present on the site and/or that habitat for federally- or State-protected that could be

occupying the site birds would be further disturbed. In addition, no ground-disturbing activities are proposed that would have the potential to unearth cultural or historical resources.

Subsequently, the ISND was revised to a Mitigated Negative Declaration (ISMND) in order to change the condition of approval to implement the Manure Management Plan to a mitigation measure to mitigate potentially significant odor impacts. This was done after realizing that the proposed Manure Management Plan was not an existing legal requirement—just a proposed condition of project approval. The Mitigation Measure is incorporated into the conditions of approval for the Project which reduces the potential impact to less than significant. Staff recirculated the document from January 3, 2025, to February 3, 2025. Four comment letters were received during the comment period. Comment letters were received from three neighbors including Jason Freeman, Stacie Bosch, and Stuart Bosch. All three comment letters did not address the adequacy of the CEQA Initial Study/Negative Declaration, and therefore, no response is necessary. A comment letter was from Colleen Platt with MyValleySprings.com and included concerns regarding the number of horses and obstruction of the access road. Comments and responses can be found at the end of the Final ISMND in Attachment 4.

2. The proposed use is consistent with the county's general plan, any applicable community or special plan, and the provisions of the applicable version of Title 17.

**Evidence:** The applicant is requesting approval of a CUP under Chapter 17.82 of the former Calaveras County Zoning Code for the operation of a private equestrian facility as defined in Section 17.06.0787 of that Code, for up to 40 horses on a Rural Residential (RR) parcel. The facility will conduct equine education and therapy sessions for at risk youth and will be operated by the landowners and 1-6 volunteers/employees and will only be available for their private invited clients or guests and not open to the general public. The facility proposes up to four lessons per day in husbandry, training, on-site preparation for off-site riding, and roping clinics for at-risk youth. Approximately two to five teenaged clients will be on-site daily, with adult volunteers/employees acting as chaperones. The applicant is also proposing to hold up to three birthday parties per year for up to 25 people. A private equestrian facility is an enumerated conditional use in the RR zone.

The parcel is designated by the County General Plan as Working Lands (WL), and although it is located within the Burson Community Plan area, there are no adopted goals or policies for this area. The RR zoning of the subject parcel is consistent with the WL land use designation. As proposed, the project is consistent with applicable goals and policies of the County General Plan including Goal LU 5.4, which encourages attraction of new compatible business and industry to the county; LU 5.5 which aims to revitalize existing community centers by encouraging a mixed-use concentration of retail, entertainment, arts, housing and services to support job and economic growth; and LU 5.6, which is to provide for a business-friendly environment with clear and efficient planning, permitting, and building

guidelines and regulations. There are no General Plan implementation measures that apply to the review of discretionary projects that are specifically applicable to this project.

3. The subject property is adequate in land area to accommodate the proposed project, its required parking area, access, landscaping, and site improvements.

**Evidence:** The subject parcel is 20 acres in size and is accessed by an existing private road- Patriot Way- via State Route 12. A parking area designated for clients is located in the southern portion of the parcel, and no site improvements are required or proposed. Calaveras County Animal Services, citing UC Davis' February 2023 Minimum Standards of Horse Care in the State of California, which it uses in its own evaluation of alleged cruelty to horses, stated that a 20-acre parcel can potentially support up to 40 horses if all standards are met, but the location of this parcel in an RR zone, how it is situated with respect to neighboring residential properties, and the use mobile paddocks on only a portion of parcel at any one time are such that 1) a Final Waste Management Plan to mitigate odor and nuisance conditions related to the potential accumulation of manure shall be required, and 2) no more than thirty (30) horses of any age shall be kept on the property at any one time. Should conditions change in the future, an amendment to the conditional use permit can be applied for to seek an increase in the number of on-site horses. Landscaping and site improvement requirements are not triggered by this application. Exhibit A to this resolution, which is attached and incorporated by reference, is a site plan reflects the status of the property at the time the application was submitted and does not reflect changes that will occur due to the conditions and mitigation measures set forth in the resolution.

4. The proposed land use is compatible with neighboring land use and zoning.

**Evidence:** The Planning Department has received multiple complaints regarding the proposed use from several of the adjacent landowners and understands that the proposed use has had nuisance impacts when operating as an unpermitted facility with no mandatory conditions in place. With approval of this CUP, the Project will be conditioned to restrict operations in order to reduce those impacts. Conditions include: restrictions on the number of vehicle trips, establishing a designated parking area for clients to park to ensure that the easement needed to access surrounding parcels remains safe and unimpeded, restrictions to allow only 5 clients and up to 6 employees/volunteers on-site per day, and up to 3 birthday parties (for a maximum of 25 invitees) per year, as well as requiring a manure management plan. Although the applicant is requesting to board up to 40 horses, Mitigation Measure AQ-1 states that "odor complaints received by the County will result in an inspection of the site to ensure compliance with the Final Waste Management Plan. If the County determines that the site is in "non-compliance" with the Final Waste Management Plan, the County can revoke CUP 2024-013. The Final Waste Management Plan, attached hereto and incorporated by reference as Exhibit D is designed not only to mitigate potential odor impacts to less than

significant but also nuisance impacts related to runoff, flies, and dust from horse manure.

5. The public and private roads providing access to the subject property meet necessary standards to provide safe and adequate access or have been amended by conditions of project approval to satisfy the access requirements.

**Evidence:** The site is accessed by Patriot Way, a gravel road accessed via State Route 12. A condition of approval recommended by Caltrans will be included on the CUP, requiring installation of the limit line and stop sign at the intersection of Patriot Way and State Route 12. The Public Works Department did not have concerns or comments relative to access, roads standards, or potential circulation impacts as a result of Project implementation. Conditions recommended by Calaveras Consolidated Fire Protection District will require that the easement must remain unobstructed with a 20' width fire lane at all times.

6. Conditions of project approval are necessary for protection of the public health, safety and welfare, and to reduce or eliminate potential environmental effects.

**Evidence:** Imposed conditions are based on review of public comments and comments made by local and state agencies and departments responsible for access, water, wastewater, public health, safety and general welfare. A review of these comments and recommendations suggested that conditions of approval are necessary to protect the health, safety, and welfare of the general public. The project does not create any hazardous roadways, reduce response times, or impact existing emergency services provided in the area.

BE IT FURTHER RESOLVED, that the Planning Commission approves Conditional Use Permit 2024-013 based on the following conditions:

## **I GENERAL CONDITIONS**

- I-1 This Conditional Use Permit will expire if not validated or extended on December 31, 2026.

## **II PLANNING CONDITIONS/MITIGATION MEASURES**

- II-1 Within five (5) calendar days from the date of approval, the applicant shall pay all applicable County Administrative fees (\$50) and State Department of Fish and Wildlife fees (\$2,968.75) to the County Recorder's Office to facilitate the filing of the Notice of Determination.
- II-2 This approval is for a Conditional Use Permit (CUP) to operate a private equestrian facility for up to 30 horses at 2911 Patriot Way in Burson. The Project shall be in conformance with the scope of project as found in the Mitigated Negative Declaration attach in Exhibit C with regard to number of vehicle trips, number of clients and employees/volunteers on-site, and number of client birthday parties per year.

- II-3 The Project shall at all times be in conformance with the project plans in Exhibit A, which is incorporated by reference herein, all conditions of approval contained herein, the mitigation monitoring and reporting program designed for this project, and the Final Waste Management Plan. It should be noted that the site plan does not reflect changes that will occur due to the conditions and mitigation measures set forth in the resolution. An application to modify the Conditional Use Permit shall be approved before the use of the site or any of its structures are expanded outside of the conditions imposed herein.
- II-4 The applicant shall at all times conform to the UC Davis' February 2023 Minimum Standards for Horse Care in the State of California.
- II-5 Amplified music shall not be permitted in association with any equestrian facility operations or birthday parties.
- II-6 The maximum number of on the ground equines shall be 30 at all times.
- II-7 The applicant shall comply with the Mitigation Monitoring and Reporting Program for Project No. 2024-013, attached hereto and incorporated by reference as Exhibit B.
- II-8 This Conditional Use Permit is subject to all applicable county ordinances, regulations or plans whether or not such requirements are specified as a condition of project.

### **III CALAVERAS CONSOLIDATED FIRE PROTECTION DISTRICT**

- III-1 Roadways must be a minimum 20' in width, must maintain an all-weather base with a minimum 40,000 lb. base at 90% compaction.
- III-2 A hammerhead or turnaround is required with a minimum turning radius of 80 feet.
- III-3 All gates must be a minimum of 20' in width and Knox access is required.
- III-4 A final fire inspection is required prior to validation of the permit.

### **IV CALTRANS**

- IV-1 A limit line (stop bar) and stop sign must be installed on the Patriot Way (private driveway) for southbound traffic before entering State Route (SR) 12. A layout of the existing driveway indicating where the limit line and stop sign are going to be located must be provided to Caltrans. In addition to the limit line and stop sign location, the layout must include the State Right-of-Way (ROW) line in order to determine if the limit line and stop sign going to be install within the State ROW or within the adjacent parcel. If the limit line and stop sign is going to be installed

within the State ROW, then an encroachment permit is required. If the limit line and stop sign is going to be installed within the adjacent privately owned parcel, then the County will coordinate with Caltrans for implementation of this condition. The applicant will be required to receive written permission from the landowner to install limit line and stop sign on their parcel.

Approved by the Planning Commission of the County of Calaveras, at a regular meeting of the Planning Commission held on March 27<sup>th</sup>, 2025, on a motion by Commissioner \_\_\_\_\_ and seconded by Commissioner \_\_\_\_\_.

AYES:  
NOES:  
ABSTAIN:  
ABSENT:  
VACANT:

\_\_\_\_\_  
Chair, Planning Commission

ATTEST:

\_\_\_\_\_  
Madeleine Flandreau  
Senior Planner

The project files are available for public review in the Planning Department, County of Calaveras, Government Center, 891 Mountain Ranch Road, San Andreas, CA. 95249, between the hours of 8:00 a.m. and 4:00 p.m.



**Exhibit B – Mitigation Monitoring and Reporting Program**

<b>Mitigation Measure</b>	<b>Timing</b>	<b>Responsibility</b>	<b>Verification</b>
<p><b>AQ-1: The applicants shall prepare and submit for review and approval a Final Waste Management Plan to the County’s Environmental Management Department prior to implementation of CUP 2024-013. Odor complaints received by the County will result in an inspection of the site to ensure compliance with the Final Waste Management Plan. If the County determines that the site is in “non-compliance” with the Final Waste Management Plan, the County could revoke CUP 2024-013.</b></p>	<p><b>At approval and to be implemented continuously during operations throughout the life of the project.</b></p>	<p><b>Owner</b></p>	<p><b>Planning</b></p>

## Exhibit C – Mitigated Negative Declaration

### CALAVERAS COUNTY PLANNING DEPARTMENT

891 Mountain Ranch Road, San Andreas, CA 95249  
(209) 754-6394

### MITIGATED NEGATIVE DECLARATION

**PROJECT NUMBER:** 2024-013

**PROJECT TITLE:** Conditional Use Permit for Lynette and Jeremy Smith-Covey  
dba 4 Horse Ranch

**APPLICANT/LANDOWNER:** Lynette and Jeremy Smith-Covey  
2911 Patriot Way  
Burson, CA 95252

**PROJECT DESCRIPTION:** The applicant is requesting approval of a Conditional Use Permit (CUP) to permit a previously existing unpermitted private equestrian facility for up to 30 horses on a Rural Residential parcel. The facility is a registered nonprofit for equine education and therapy sessions for at risk youth and will be operated by the landowners and 1-6 volunteers/employees and will only be available for their private invited clients or guests and not open to the general public. The facility proposes up to four lessons per day in husbandry, training, preparation for off-site riding, and roping clinics for at-risk youth. Approximately two to five teenaged clients will be on site daily, with adult volunteers/employees acting as chaperones. The applicant is also proposing to hold up to three birthday parties per year for up to 25 people. The horses are kept in paddocks with moveable fencing for periodic rotations. No development is proposed at this time.

**PROJECT LOCATION:** The parcel is located at 2911 Patriot Way, Burson, CA, APN 048-009-052 in a portion of Section 21, T04N, R10E, MDB&M

**GENERAL PLAN LAND USE DESIGNATION:** Working Lands

**ZONING DESIGNATION:** Rural Residential (RR)

#### FINDING FOR MITIGATED NEGATIVE DECLARATION:

1. Revisions in the project plans or proposals made by, or agreed to by, the applicant before the proposed Mitigated Negative Declaration and Initial Study are released for public review would avoid the effects or mitigate the effects to a point where clearly no significant effect on the environment would occur.
2. On the basis of the whole record including the Initial Study and comments received, there is not substantial evidence in the public record that the project may cause a

significant effect upon the environment and the Mitigated Negative Declaration reflects the Lead Agency's independent judgment and analysis.

**EVIDENCE:**

Pursuant to California Environmental Quality Act (CEQA) guidelines, County staff provided review and concurrence with the Initial Study evaluating the potential environmental effects of the project. The Initial Study identified potentially significant adverse effects under Air Quality. A mitigation measure was incorporated into the Initial Study, which mitigated the potentially significant impacts to less than significant and a Mitigated Negative Declaration was prepared. The Initial Study/Mitigated Negative Declaration (ISMND) was distributed for a 30-day review and comment period between January 4, 2025, and February 3, 2025. Three comment letters were received from neighbors in opposition to the project, and did not address the adequacy of the CEQA Initial Study and Mitigated Negative Declaration. One comment letter was received from Colleen Platt with MyValleySprings.com with concerns regarding the potential for obstruction of the easement, as well as proper care of equines. The County's responses can be found attached to the ISMND. A Mitigation Monitoring and Reporting Program (MMRP) has been prepared to ensure compliance during project implementation. A condition of approval has been imposed on the project that requires conformance with the MMRP.

**MITIGATION MEASURES FROM ENVIRONMENTAL DOCUMENT:**

<b>MITIGATION MEASURE AQ-1</b>
The applicants shall prepare and submit for review and approval a Final Waste Management Plan to the County's Environmental Management Department prior to implementation of CUP 2024-013. Odor complaints received by the County will result in an inspection of the site to ensure compliance with the Final Waste Management Plan. If the County determines that the site is in "non-compliance" with the Final Waste Management Plan, the County could revoke CUP 2024-013.



**PREPARED BY:** \_\_\_\_\_  
Madeleine Flandreau, Senior Planner

**APPROVED BY PLANNING COMMISSION**

\_\_\_\_\_  
**Chairperson** \_\_\_\_\_  
**Date**

## Exhibit D- Manure Management Plan



# Calaveras County Planning Department

---

**Bret Sampson – Planning Director**  
Phone (209) 754-6394 Fax (209) 754-6540  
[www.planning.calaverascounty.gov](http://www.planning.calaverascounty.gov)

---

March 19, 2025

## Final Waste Management Plan

The following contains Manure “Best Management Practices” that shall be implemented to ensure that odor, insect, and water quality impacts are addressed for the 4horse Conditional Use Permit. The Best Management Practices are taken from staff recommendations or:

*Horse Manure Management (A guide for Bay Area Horse Keepers). Bay Area RCDs.*

*Horse Keeping: A Guide to Land Management for Clean Water. Bay Area RCDs.*

Both of these documents are included as attachments to the Staff Report Addendum.

### Collection

- Manure shall be cleaned from stalls and paddocks once a day.
- Stalls and paddocks should be kept clean and dry.
- Usable bedding should be used in stalls after daily cleaning of manure.

### Temporary Storage

- All manure shall be kept within a covered area no less than 100 feet from any property line.
- Storage areas must be designed to safely contain the total volume of manure anticipated to be generated within the storage period.
- Stored manure shall be moved to a composting area once a month.
- Surface run-off should be prevented from entering the storage area from the surrounding land.
- Clean surface water, including roof run-off, should not be commingled with manure-contaminated water.

### Utilization and Disposal

- Composting: Windrows or piles shall be no more than 7 to 8 feet in height. Windrows or piles shall be turned at least once a month. Windrows or piles shall be no less than 100 feet from any property line. Windrows or piles shall be covered during rain events.
- Land Application: Manure may be spread in pasture areas up to one inch in depth.
- Off-site Disposal: Off-site disposal of compost or manure is allowed at a certified land fill and or a commercial composting site. The California Integrated Waste Management

Board (CIWMB) provides a list of commercial composting sites that accepts manure and bedding. This information is available on the CIWMB website ([www.ciwmb.ca.gov](http://www.ciwmb.ca.gov)) Conveyance of compost or manure to a third party for profit and or free of charge is allowed. The CIWMB also maintains a website for the California Materials Exchange ([www.ciwmb.ca.gov/calmax](http://www.ciwmb.ca.gov/calmax)) which links those looking for organic materials with stable providing manure.

### **Environmental Considerations**

- **Drainage:** Install straw waddle strips on the downward slopes of all paddock and stall areas. Ensure that fence lines contain vegetative strips.
- **Run-off prevention:** Construct berms or barriers to contain run-off from reaching waterways.
- **Leachate Control:** Ensure leachate is not seeping from manure piles and prevent from reaching waterways.

### **Health Considerations**

- **Parasite Control:** Remove manure from areas where animals are confined (stalls, paddocks) within 24 hours to prevent larvae development. Remove manure from pastures regularly. Composting manure in windrows can kill parasite eggs and larvae through the heat generated during decomposition.
- **Pathogen Reduction:** Do not spread uncomposted manure. Use strategies including composting which can reach high temperatures to kill pathogens and parasites in addition to lime application that is safe to use around horses and the environment.
- **Proper Handling:** Use appropriate Personal Protective Equipment (PPE) when participating in manure management practices.

Attachment 2-  
Applicant's Draft Manure Management Plan

4 Horse ranch land and animal management program,

4 Horse Ranch has less than 50 horses on premises. We have a few dogs. We have a few chickens and a few goats. We have had a couple cows and have plans to have them again.

We have 20 acres. We have pens for the horses. Both portable and fixed. We have some panels and some tee post and wire style fencing.

We use a tractor to scrape heavy manure out of the pens. We have a few manure piles around the area strategically located far from neighboring wells. These piles are turned regularly to create dirt. Also, they are spread out instead of remaining in a pile as the dirt starts to mature. Eventually they are a wonderful dirt mix that grows healthy plant life. We use this mix to fortify any areas we feel need built up. It has helped our trees and grasses and helped minimize fox tails and other unsavory weeds in our grassy areas. Also we get great zucchini and tomatoes in our garden.

After scraping the pasture we spread lime. This is for deodorizing as well as further elimination of mites and other pests.

We have built a few berms to prevent heavy water flow and erosion into the neighbors property. We like to build pastures back up preventing heavy erosion over time. We like to keep grass on every fence line to help prevent any water run from carrying manure even in a heavy rain.

Our piles are very beneficial to our land. We do offer compost pick up in the front area when asked.

We have chickens that free range to help break up manure and remove pest larva. We use beneficial bugs often called fly predators. We purchase these bugs every 6 weeks and spread them anywhere there might be fly larva. We also purchase lady bugs and praying mantises.

Every pasture has fly blocks. This is a free feed block a lot like a salt lick that allows the horses to lick or chew away boredom. The ingredients passes through the manure breaking life cycles of the fly and worms while not harming the chickens.

The chickens are provided with a diatomaceous earth dust bath. This dust is used on walk ways also so it helps control harmful mites and worms as well.

The paddocks can occasionally get a little wet from manure and urine when concentrated in one spot. Horse stall pellets these are cedar or pine and are used in these areas to help with dust, smell and repel bugs.

Attachment 3-  
Horse Manure Management (A guide for Bay  
Area Horse Keepers)

# ***HORSE MANURE MANAGEMENT***

*A Guide for Bay Area Horse Keepers*



## **Purpose of this Guide**

Proper manure management is an important concern for every horse keeper. Appropriate storage, handling, recycling or disposing of horse manure protects water quality and keeps both horses and people healthy and happy. Good manure management is essential for horses to be accepted as friendly residential neighbors in increasingly crowded suburban settings. Almost forty-five percent of horses nationwide are said to be housed on private residential property. This publication has been developed to provide you with the basic guidelines for best manure management practices and to minimize environmental impacts from your horses or your horse keeping operation. Furthermore, it provides examples of what others are doing to dispose of their manure in the Bay Area, including information based on demonstrations funded under this study.

The reader is encouraged to read the manual "Horse Keeping: A Guide to Land Management for Clean Water," that is being adopted by horse keepers throughout the Bay Area as an effective management tool in a Nonpoint Source Pollution (NPS) control program. Further reading on manure management topics and a glossary of terms are listed in the reference section at the end of this publication.

## **ACKNOWLEDGEMENTS**

### **Description of Bay Area Manure Management Program**

The Council of Bay Area Resource Conservation Districts (CBARCD) developed a partnership with equestrian organizations, the USDA Natural Resources Conservation Service (NRCS), Region 2 of the State Water Resources Control Board (SWRCB), and four Resource Conservation Districts (RCDs) in Alameda, Marin, San Mateo and Southern Sonoma counties, to address horse keeping and potential water quality problems that might be attributed to horses. Funding was secured through the regional board using federal Clean Water Act funds. The goal of the program is to minimize or eliminate potential non-point source pollution from horses that may enter Bay Area creeks and streams while improving and protecting water quality through best management practices. The first phase of the project, which concludes in December 2003, looked at conservation practices that apply to equestrian facilities and resulted in a manual on best management practices for horse keepers. The second phase of the project has specifically addressed on-site manure management at equestrian facilities. During both phases, educational materials were produced and workshops and hands-on demonstrations were carried out. This transfer of appropriate information, practices, and technology to horse keepers helps achieve the overall goal of fostering long term stewardship of our many and varied natural resources in the Bay Area.

### **Lead Author**

Marc Buchanan, PhD  
Buchanan Associates, Scotts Valley, CA

### **Contributing Editors**

Jeff Creque, Golden Bear Land and Water  
Adda Quinn, EnviroHorse and San Mateo RCD Equine Committee  
Tristy Schewe, Marin Resource Conservation District  
Jason Sweeney, Southern Sonoma County Resource Conservation District

### **Core Work Group**

Mike Ednoff  
Krissa Lebacqz  
San Mateo Resource Conservation District

Amy Evans  
Alameda County Resource Conservation District

Melissa McCoy  
Tristy Schewe  
Marin Resource Conservation District

Chris Delaney  
Jason Sweeney  
Southern Sonoma County Resource Conservation District

Dave Nicholson  
Marin County Stormwater Pollution Prevention Program

Funding for all publications in this series was provided in part by the U.S. Environmental Protection Agency pursuant to Assistance Agreement No. C9-989697-00-0 and any amendments thereto which has been awarded to the State Water Resources Control Board for the implementation of California's Nonpoint Source Pollution Control Program. The contents of this document do not necessarily reflect the views and policies of the USEPA or the SWRCB, nor does mention of trade names or commercial products constitute endorsement or recommendation for use.

### **Defining NonPoint Source Pollution**

Nonpoint source (NPS) pollution is defined as the accumulation of small pollution sources (like manure piles or paddocks) and single pollution events that as a whole cause significant degradation to water quality. The term nonpoint contrasts with point sources of pollution that originate from a discharge, such as from a sewage plant or factory. Nonpoint source pollution is not as definable and includes runoff from roads, parking lots, and other paved surfaces and urban areas. Rural runoff from farms, stables, and ranches may also contribute to nonpoint source pollution and needs to be controlled. In the 1986 EPA Report to Congress, the nation's remaining water quality problems were largely attributable to pollution from non-point sources including runoff from soil erosion, nutrients, and chemicals (CAST 1992). The initial approach being undertaken nationally by the government is to seek voluntary compliance to eliminate nonpoint sources of pollution, while requiring permitting and utilizing enforcement actions for the large and significant sources. In 1999, EPA reported that while many water bodies have been cleaned up substantially, 40% of the Nation's waterways assessed by states still did not meet water quality goals for fishing, swimming or both ([www.epa.gov/owm/finafost.htm](http://www.epa.gov/owm/finafost.htm)). The program to eliminate NPS pollution is being promoted through education that encourages voluntary participation and stewardship in improving water quality. This publication has been created as part of that educational effort.

## Table of Contents

Purpose of this Guide  
Acknowledgement

---

<b>1. Horses and Manure</b>	<b>7</b>
<b>2. Manure Management Options</b>	<b>8</b>
2.1 Guidelines for Handling and Temporary Storage of Manure	8
Manure Storage	8
Minimize Runoff	9
Setbacks and Buffer Strips	10
2.2 Pasture Management	10
Pasture Buffer Guideline	11
2.3 Land Application	11
Land Application Guidelines	11
2.4 Off-site Disposal and Recycling	13
<b>3. Composting Manure</b>	<b>14</b>
3.1 On-site Composting	14
A Manure Pile Does Not Constitute Composting!	14
Composting Solves Problems and Increases Value	14
3.2 Basic Composting Theory and Practice	15
Compost Requires Management	15
Dealing with Woody Bedding Materials	15
Hands-On Experimentation for the Novice Composter	17
Five-Gallon Bucket Test	17
Does Your Manure Bedding Mix Require Additional Water?	17
What Compost Method is Best for You?	18
3.3 Size of Operation Determines Site and Technology	20
Compost Technologies and Management	22
Managing the Compost Process	23
Monitor Compost Temperatures	24
When is That Compost Done?	25
Laboratory Analysis of Compost	25
3.4 Composting Economics	25
3.5 Composting Summary	26
<b>4. On-Site Composting Case Studies</b>	<b>27</b>
4.1 Case Study #1	27
4.2 Case Study #2	29

## Table of Contents

---

4.3a	Case Study #3	30
4.3b	Case Study #3	32
4.4	Case Study #4	33
<b>5.</b>	<b>Glossary</b>	<b>35</b>
<b>6.</b>	<b>References</b>	<b>36</b>
<b>7.</b>	<b>Sources For Further Technical Assistance</b>	<b>38</b>

### Tables and Figures

Table 1.	Average nitrogen, phosphorus, and potassium content (NPK) of horse manure and manure with bedding	7
Table 2.	Average amount of storage required for manure	9
Table 3.	Average manure application and land base area requirements for pasture crops	12
Table 4.	Separation distance from streams, rivers, and lakes for land spreading of manure	13
Figure 1.	The aerobic compost process	16
Figure 2.	Example of idealized compost site details	21
Figure 3.	Cross-section of an idealized detention basin	22
Figure 4.	General design for horse manure compost bin	23

## 1. HORSES AND MANURE

University researchers have determined that, on average, a 1,000 pound (lb) horse can generate 8-10 tons of manure a year, accumulating at the rate of approximately 0.75 cubic feet per day. This equates to roughly 12-15 cubic yards of manure annually. Daily manure may consist of 30 lbs of feces plus 20 lbs of urine. Manure contains plant nutrients, soluble and insoluble organic compounds, and microorganisms. Additionally, at an average of 1 cubic foot per day, bedding can add up to 13.5 cubic yards of waste materials annually to the manure. Manure and used bedding must be properly handled, stored, and disposed or recycled.

Manure has a long history of use as a soil amendment and alone can be a valuable source of nutrients for plant growth. The composition of this waste material varies depending on the type and quantity of bedding used, age and function of the animal, type of feed, and how the manure is stored. Use of bedding, such as softwood shavings, sawdust, straw, or other organic materials will tend to reduce the total nutrient content per ton. Conversely, the addition of large amounts of wasted hay or other feed will increase the nutrient content of the manure and bedding. Table 1 gives an average nitrogen, phosphorus, and potassium (NPK) content of horse manure alone and with bedding. Horse manure also contains many other plant macro- (e.g. calcium and magnesium) and micro- (e.g. copper and zinc) nutrients.

**Table 1.** Average nitrogen, phosphorus, and potassium content (NPK) of horse manure and manure with bedding (dry weight basis)

NUTRIENT	MANURE	WITH BEDDING
	%	LBS./ TON OF MATERIAL
Nitrogen (N)	0.95	11.0
Phosphorus (P)	0.30	2.20
Potassium (K)	1.50	1.30

As shown, horse manure can be a good fertilizer. Horse manure is underutilized as a soil amendment. It can build soil organic reserves, resulting in improved water-holding capacity, increased water infiltration rates, and improved structural stability. Manure can decrease the energy needed for tillage, increase root penetration and the ability of a seedling to sprout, stimulate growth of beneficial soil microbial populations, and increase the number of beneficial organisms such as earthworms. Horse manure is prized by home gardeners and commercial nurseries because it is less dense than other types of animal manure. It is dry with a high carbon to nitrogen, or C:N ratio. It composts well alone or as an amendment with wet cattle or poultry manure. It has low odor potential, and decomposes rapidly, especially if it is not mixed with large quantities of bedding.

*For more information and web sites on horse manure as a soil amendment, please refer to list of references supplied in this guide or contact your local RCD, NRCS, or other technical information provider also listed in this guide.*

## 2. MANURE MANAGEMENT OPTIONS

In many locations in the San Francisco Bay Area, horses are confined in small paddocks due to limited land areas available for full-time pastures. Therefore, manure and bedding are removed regularly and may potentially accumulate in large piles, rather than being naturally spread in random patterns over a pasture. Manure piles poorly placed in proximity to road ditches, other drainage swales, and creeks or streams can pose risk to water quality.

The following guidelines, along with additional information and reading contained in the References section, can assist the horse keeper with the handling and storage of manure.

### 2.1 Guidelines for Handling and Temporary Storage of Manure

Care and feeding of horses in small, confined areas requires regular removal (daily, if possible) of manure from stalls and paddocks. Stalls and paddocks should be kept clean and dry. Decomposition of manure starts as soon as it's voided. Decomposition rates of manure depend on handling and storage methods. Horse manure stockpiles should be kept compact and moist to prevent excessive nutrient losses. When left in a loose heap or scattered piles, it loses nitrogen rapidly to the atmosphere in the form of ammonia. Urine has a much higher nitrogen content than manure and bedding and these nutrients are more readily available as fertilizer. Bedding used in horse stalls absorbs and holds this valuable component well. Care should be taken to leave behind usable bedding when manure is removed from stalls. Some stables encourage separation of manure-with-some-shavings and pure manure so that separate storage and recycling areas can be established similar to approaches used with yard waste. Such separation aids manure composting by reducing the overall volume of waste and the time needed for the composting process. This may significantly reduce the overall costs for disposing of the waste or compost.

#### *Manure Storage*

Table 2 shows average volumes of manure and manure plus bedding generated by a typical horse facility over a one-year period. Storage areas must be designed to safely contain the total volume of manure anticipated to be generated within the storage period. For example, a storage area designed to contain all the manure and bedding from one horse for an entire year should be large enough to contain up to 20 cubic yards of material. This could be accomplished in a storage area measuring approximately 12 x 12 feet, assuming material is piled to a depth of 3 to 5 feet. If, however, manure is moved from storage to a composting area on a monthly basis, the storage area could be designed to contain one twelfth that volume, or about 2 cubic yards. In that case, the storage area could be as small as 3 x 6 feet, with a pile height of 3 feet.



*Wheelbarrels with fat tires are a basic manure management tool*

Storage sites should be located so that loading and unloading is convenient. Surface runoff should be prevented from entering the storage area from the surrounding land, and runoff of contaminated water from the storage area should be prevented entirely by roofing or covering the storage area with a tarp. If water does leave the storage area, it should be channeled to a containment area, grassed waterway or similar structure to insure it does not enter waterways or otherwise contaminate clean surface or ground water. Clean surface water, including roof runoff, should not be commingled with manure-contaminated water.

As can be seen from table 2, larger horse facilities require much larger storage capacities. In such cases, containing and covering manure may be impractical, requiring storage on open areas. In such cases, the proper management of site run on and run off is essential.

**Table 2** Average amount of storage required for manure \*

NO. OF HORSES	MANURE*		MANURE W/BEDDING*	
	250 DAYS	YEAR	250 DAYS	YEAR
	CUBIC YARDS			
1	7	10	12-14	17-20
5	35	50	60-70	85-100
15	105	150	180-210	255-300
25	175	250	300-350	425-500
40	280	400	480-560	680-800

\*Assumes 0.75 cu.ft. of manure/day and 0.50 to 0.75 cu.ft. bedding/day (a cube 3-ft. x 3-ft. x 3-ft. is 27 cu.ft. and is equal to 1-cubic yard).

### **Minimize Runoff**

Encourage stormwater infiltration into the ground on your property to reduce runoff, and thus the **potential** transport of nutrients and pathogens from manure to water bodies. Small grassed depressions in your pasture can act as detention basins that capture water, filter sediment and nutrients from the water, and encourage infiltration. Divert storm runoff from high traffic areas and paddocks by constructing grassed swales or diversions. If necessary, due to predictable high rainfall, a berm should be built behind and around the storage area to prevent runoff from draining directly into water bodies. **Never** store manure in the pathway of storm water runoff that is heading downhill to a drainage or stream.



*An impermeable surface, graded to control runoff.*

A basic management and stewardship practice is to “Keep Clean Water Clean.” For example, barns should be equipped with gutters to direct water away from paddocks and manure storage

areas to dry wells, clean water ponds or grassed waterways. Keeping clean water clean is easier than managing and treating it once it has become contaminated with manure or sediments.

### ***Setbacks and Buffer Strips***

In addition to reducing runoff potential through the use of berms, roofs, etc., maintain a vegetated buffer strip along ditches, stream banks and ponds wherever possible. Such buffers are highly effective at filtering sediment and nutrients from surface waters flowing through them. Safe buffer widths can vary, depending on slope, soil type, type of vegetation and other factors. A minimum buffer width of 50 feet is recommended in most cases, but 100 feet may be needed along reservoirs and public water supply tributaries. Where buffers are not vegetated, or storage area runoff controls are inadequate, the USDA-NRCS recommends buffers up to 200 feet wide. This may be impractical, or impossible on some sites. Be sure to check local regulations for specific guidelines and required permits, if any.

## **2.2 Pasture Management**

Management of pastures is much different from management of paddock and stall areas. Pasture, while not essential, can provide an inexpensive supply of high quality feed with all the protein, vitamins, and minerals needed by horses. However, pastures can vary greatly in productivity. Pasture productivity is related to: (1) the number of animals per unit area; (2) vegetative makeup of the sod; and (3) the natural fertility of the soil. Too often, horse pastures are grazed throughout the growing season without rotation. One to two acres of well-managed pasture can support one mature horse during the grazing season with rotation. When the animal is rotated as frequently as every two weeks, the acreage needed could be closer to one acre. Four to five acres of unimproved native grass pasture will support only one mature horse for the entire grazing season.

Horses can do a fairly good job of distributing manure. However, concentrated droppings from horses can suffocate or stunt plants underneath them. To maximize pasture production, drag or harrow the pasture to break up the droppings and more evenly spread the manure. To avoid concentration of manure in one or more isolated areas, the horse keeper should encourage even grazing. If horses in the pasture receive supplemental feed, try moving the feeding location around. Keep horses out of streams, lakes, ponds, and wetlands. If you cannot completely fence your horse out of these areas, build water crossings to limit access as much as possible. Consider alternative water sources, such as troughs or an automatic watering system.



*Pastures should be managed to control parasites.*

Horses are susceptible to more species of internal parasites than any other kind of livestock. Seldom are the outward symptoms of internal parasites evident in the mature horse, that owners may not be aware of infection. Uncomposted horse manure disposed on horse pastures risks spreading internal parasites. Fortunately, only a few internal parasites present a problem (ascarids, strongyles, bots, pinworms). Fresh manure should only be spread on inactive pastures. Ideally with small pastures, the horse should be rotated to a fresh area about every two weeks to break up the life cycle of internal parasites.

### ***Pasture Buffer Guideline***

Maintain a 100-foot vegetated buffer strip near reservoirs and along public water supply tributaries and a minimum 50 foot buffer from banks of other streams and ponds.

### **2.3 Land Application**

Where enough land area is available, manure can be safely and efficiently used as a soil conditioner to improve cropland, landscape plantings or pastures. On cropland, a two inch layer of manure incorporated into the surface soil immediately after spreading can help improve soil fertility and help prevent losses of nutrients, particularly nitrogen, from the manure to the atmosphere. Manure can be used as a two to four inch surface mulch in landscaped areas to suppress weed growth and conserve soil moisture.



*Finished compost can be used on site as a beneficial mulch.*

On pasture areas, manure can be spread evenly to a depth of one half to one inch without suppressing pasture vegetation, ideally just prior to fall rains. Tillage in permanent pastures is generally undesirable, as it leads to destruction of the existing sod and the need for reseeding and reestablishment of pasture vegetation before grazing can resume. Because manure can contribute to contamination of runoff during heavy rains, be sure to maintain appropriate buffers between water bodies and areas where manure is applied, whether spread on the surface or tilled in to the soil.

### ***Land Application Guidelines***

Knowing the nutrient content of stored manure will increase the potential for effective absorption of manure nutrients by soil and plants and reduce potential for leaching or runoff risk. Although each source of horse manure will vary, a standard "NPK" value (Table 1) can be used to determine the number of acres needed to properly spread the horse manure. When using stored manure in place of purchased fertilizer, you may wish to have a more accurate estimate of its nutrient content. Manure can be sampled, packaged, and sent to a testing laboratory for nutrient analysis. (*Contact your local RCD, NRCS, or Farm Advisor for further technical assistance and locations of laboratories*).

Calculating manure application rates is a mathematical exercise that aligns the nutrients supplied in the manure and the nutrient demands of the crops (Table 3). Not all of the nutrients in

manure are available for plant use. For example, the percentage of the total nitrogen available is a function of the method of manure application and management as well as the age and chemical composition of the manure. For horse manure, nitrogen content typically ranges from 35 percent of the total nitrogen if the manure is spread and left on the soil surface, to 60 percent if the manure is spread and worked into the soil within a day. Phosphorus and potassium uptake is commonly assumed to be 60 and 90 percent of the total available, respectively. If large amounts of bedding are present in manure, it will have a high carbon and low nitrogen content which can tie up nitrogen temporarily until the bedding decomposes. A supplemental source of nitrogen could be needed to offset this nutrient imbalance.

**Table 3.** Average manure application and land base area requirements for pasture crops.\*

FORAGE CROP	ANNUAL MANURE APPLICATION	LAND AREA REQUIRED
	TONS/ACRE	ACRES/HORSE/YR
Red Clover	10	0.8
Ryegrass	11	0.8
Tall Fescue	13	0.6
Wheat Grass	2	3.8

\*Adapted from Davis and Swinker, 1996 (assumes 8 tons of manure/yr).

**Example 1 (from Table 3)**

A horse keeper with 2 acres of land intended for seeding of tall fescue and ryegrass would require:

$$12 \text{ tons manure/acre} \times 2 \text{ acres} = 24 \text{ tons of manure}$$

**Example 2**

A horsekeeper has 2 acres of established ryegrass and tall fescue which can utilize nutrients in 12 tons of manure applied per acre. This pasture can safely “recycle” the manure from how many horses?:

$$2 \text{ acres} / 0.8 \text{ acres/horse} = \text{annual manure from 2.5 horses}$$

Certain fields or portions of fields must be excluded from manure application based on environmental precautions. Some guidelines are listed in Table 4. After you determine application rates, you need to make some decisions about the method of application. The primary goal is to apply manure uniformly throughout the field. The timing of the manure application is also important. The ideal scenario is to spread manure in the spring. This supplies nutrients for the upcoming growing season and minimizes the amount of time for potential losses before crop uptake. Avoid applying manure in winter. Manure applied during the rainy season can be susceptible to leaching or runoff.

**Table 4.** Separation distance from streams, rivers, and lakes for land spreading of manure.\*

<b>Slope</b> (%)	<b>Soil texture</b>	<b>Setback</b> (feet)
0-3	Sand-sandy loam	50
3-6	Sand-sandy loam	100
0-3	Loam to clay	50
3-6	Loam to clay	150
Over 6	Sand-sandy loam	200

\*Setbacks will vary depending upon local regulations, the condition of vegetation in the buffer, soil type, slope, and rainfall regime. These are generalized figures and as such, the reader is advised to first check with their local planning department, NRCS, or RCD field office.

## 2.4 Off-Site Disposal and Recycling

Unfortunately, significant quantities of horse manure and bedding are hauled to landfills each year. At the same time, gardeners, landscapers, and small farms in your area may be seeking organic amendments. Fresh manure and bedding may be preferred by some, but may raise concerns due to the potential presence of pathogens and weed seeds. Properly aged manure from your storage area might be more preferable to some. Your manure and bedding is a potentially valuable resource. There may be ways to give or truck it away for uses that cost less than land-filling and are more environmentally desirable. Disposing of manure to a landfill can be quite costly due to trucking costs and the ever increasing “tipping fees” charged at disposal sites. In addition, all landfills are trying to extend their "life" through recycling programs and horse manure is a recyclable waste.

Another alternative is to find a commercial composting operation close to where your horses are kept that may accept your manure and bedding for less cost than a landfill. Throughout California there are numerous municipal and private operations that compost a variety of organic wastes. The California Integrated Waste Management Board (CIWMB) provides a list of commercial composting sites that may accept your manure and bedding. This information is available on the CIWMB website

([www.ciwmb.ca.gov](http://www.ciwmb.ca.gov)) or by calling (916) 341-6000. The CIWMB also maintains a website for the California Materials Exchange

([www.ciwmb.ca.gov/calmax](http://www.ciwmb.ca.gov/calmax)), which links those looking for organic materials with stables providing manure. A final alternative is to work with other horse keepers, equestrian organizations, livestock operations, and your Resource Conservation District, to develop a community or regional composting facility that accepts manure from horse keepers.



*Small bin system with space between boards for aeration.*

### 3. COMPOSTING MANURE

Composting may be defined as the controlled breakdown or degradation of organic material into a product known as humus. Composting is an excellent way of disposing and recycling horse manure. Composting manure decreases the volume of waste, makes handling waste easier, and transforms a potential liability into a marketable resource. The following sections describe the basic considerations for composting horse manure.

#### 3.1 On-site Composting

Often, horse owners and managers don't have access to enough crop or garden land to use all of their valuable manure. Composting offers a means of enhancing the material for on-site use while also reducing its volume. While composting takes additional time and expense, it can have a number of advantages depending on the specific needs of your site. Composting can be more expensive than land spreading of manure. However, many who have become avid composters believe that the added benefits of composting far outweigh the costs. Composting of horse manure alone can take 30 to 60 days, while manure with bedding may require as long as 6 months for complete composting.

#### *A Manure Pile Does Not Constitute Composting!*

Composting is a **managed** process that accelerates decomposition and conversion of organic matter to stable humus. Composting manure is an effective way to transform waste into a valuable resource for pastures, fields, and/or gardens. During the composting process, a large mass of "hungry" microbes break organic materials into smaller physical and chemical particles and build new organic molecules. Composting is both an art and a science. Good composting practice involves maintaining the optimal environmental conditions for microbial growth (water, air, organic matter or carbon, and nitrogen). Merely piling manure for some undetermined time is not composting!

#### *Composting Solves Problems and Increases Value*

Composting can reduce the total volume of manure and bedding generated on your property. Thorough composting will typically reduce the initial volume of material by 40 to 50 percent. Good composting can reduce the risk of manure to water quality by:

- *Reduction and elimination* of microbial pathogens;
- *Reduction* of ammonia-N levels;
- *Reduction* in water-soluble phosphorus;
- *Reduction* of water-soluble organic matter (BOD); and
- *Reduction* in total soluble salts.

In a process called aerobic thermophilic composting, microbial activity creates heat that causes the pile to reach temperatures that can kill weed seeds and eliminate pathogens and parasites. Flies are reduced because breeding conditions are eliminated. Composting removes the odor and results in a valuable product that can be sold. The finished compost is a valuable soil amendment, adding nutrients, organic material, and texture to the soil.

## 3.2 Basic Composting Theory and Practice

### *Composting Requires Management*

The basic elements of composting involve maintaining adequate air (oxygen), temperature, and moisture necessary for microbes to flourish. Horse manure and bedding typically contains the correct ratio of carbon to nitrogen necessary for successful composting, although occasionally this may require adjustment. The decomposing manure and bedding in compost is a carbon and nitrogen “converter” fueled by oxygen, high temperatures, and water. In order to function, a compost pile must have sufficient “breathing” spaces for the microbes and allow the carbon dioxide from their breakdown of organic matter to exit. Moisture is key to maintaining a habitat for large microbe populations. Another challenge is to ensure the proper proportions of the materials in the compost. The type and amount of bedding will substantially affect the ease and rate of composting. Less bedding in the compost results in a faster process and a higher quality final product. Different types of organic materials compost differently. You’ll need to customize the process to fit your specific combination of manure, bedding, and other organic materials. You can find the best mixture by developing a clear understanding of the process, accurately measuring materials, and going through some trial and error.



*Compost with woody bedding material.*

### *Dealing with Woody Bedding Materials*

Typical bedding materials such as shavings and sawdust can create challenges for composting and the production of a quality finished product. Wood is composed of complex organic compounds rather than simple ones. A compound called lignin is an important component of wood because its chemical structure resists decomposition by many microbes that may flourish in a compost pile. In fact, only a small proportion of microbes (predominantly fungi) can completely decompose lignin to carbon dioxide and water. Therefore, the breakdown of woody material is slow even in the most active composting process. Too much woody bedding will result in a lower quality compost product with a high C:N ratio that is less desirable for tilling into the soil. Adding nitrogen to reduce the initial C:N ratio is more cost-effective than adding special microbe inoculants that are on the market and may be necessary in some cases.

### Air

In the presence of oxygen, organic material degrades. Approximately two-thirds of the compost piles’ initial volume should be interconnected free air space. Air space allows oxygen to move into the pile while allowing carbon dioxide and water vapor to leave. Horse manure combined with ample wood shavings or straw is porous and very permeable to gases because of varied particle size. Mixtures of manure and sawdust require a slightly higher degree of management to maintain adequate permeability in the compost bulk. If managed properly, however, sawdust will compost faster than coarser bedding materials. Too little air space reduces the oxygen available to the microorganisms while too much air space dries the pile out and prevents it from reaching temperatures high enough to compost effectively.

## Carbon and Nitrogen

Horse manure alone will have close to the optimum proportions of carbon and nitrogen that compost microbes require. Carbon is the major component of organic matter (45 to 55 percent) in manure and bedding. A long established “rule of thumb” suggests that a starting carbon-to-nitrogen ratio (C:N ratio) of 25 - 35:1 is optimal for composting. Horse manure may range from 25:1 to 50:1. However, with the addition of bedding, particularly that derived from wood, C:N ratios will be higher as the bedding contains much higher amounts of carbon. Given this reality, manure, hay, and bedding must be relatively fresh for optimal composting so that the microbe-available carbon and nitrogen is high. Alternatively, when bedding such as sawdust, rice hulls, or shavings is used in high proportions, additional nitrogen might need to be added to enhance the decomposition of the woody material. This additional nitrogen might be supplied with fresh grass clippings, hay, or fertilizer.

## Temperature

The highest quality compost is produced at internal compost pile temperatures ranging between 131 to 150 degrees F (Rynk, 1992). The above factors of air and water have much to do with achieving these temperatures. At these elevated temperatures, microbial pathogens are destroyed and all but the most hardy weed seeds are killed.

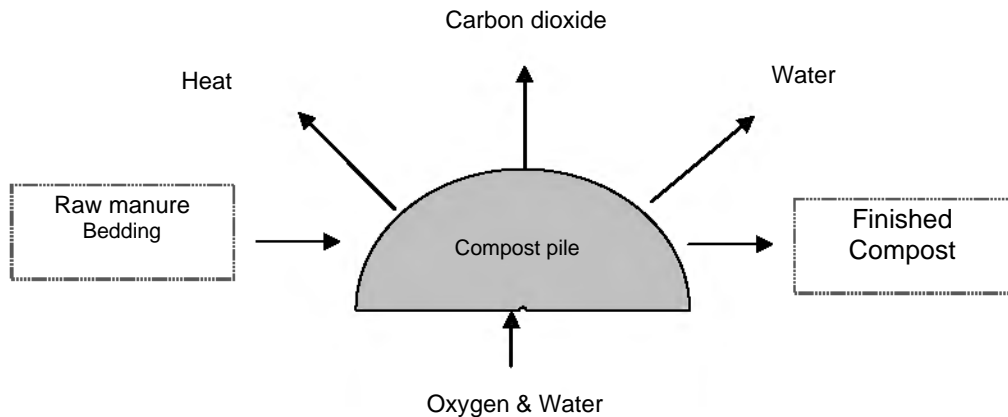

Figure 1. The aerobic compost process

## Water

Water is required for good composting. Microorganisms grow best with a moisture content of around 50 - 60 percent by weight of the compost pile (Rynk, 1992). If the compost feels like a freshly wrung out sponge, the pile most likely contains the proper amount of moisture. If water runs out of the pile or if you can squeeze water from a handful of compost, it is too wet. Too much water can reduce the supply of oxygen and allow offensive odors to develop. Closely monitor the moisture level, especially during hot, windy days when as much as 5 percent (water equivalent) of the pile’s total dry weight can be lost. Adding a little water regularly is much better than letting the pile get dusty and dry, then trying to rewet it back to the 50 percent range.



Commercial test kits are available.

### ***Hands-On Experimentation for the Novice Composter***

Before you build a small or large compost pile, it might be good to do some additional “homework”. You may want to test your manure and bedding mixture to get an actual carbon and nitrogen value (see sample and testing section). Even if you choose to use the above-mentioned rules of thumb for average C:N ratios, you may find that a direct determination of your mixture’s air space and initial water requirements will be helpful. The following method (from the University of Minnesota Extension Service) can assist the novice composter in “dialing in” the proper aeration.

### **Five-Gallon Bucket Test**

Materials needed:

- ✓ five-gallon pail
  - ✓ one-gallon pail
  - ✓ typical mix of materials to be added to the compost pile (manure, wood shavings, straw, etc.)
- 
- Fill the five-gallon pail one-third full with a mixture of typical pre-compost materials. Drop the pail 10 times from a height of six inches onto a concrete floor or solid surface to pack the material. Be careful not to spill any of the compost materials.
  - Add more material to fill the five-gallon pail two-thirds full. Drop the pail 10 more times from a height of six inches.
  - Fill the five-gallon pail up to the top. Drop the pail 10 times from a height of six inches. Fill the five-gallon pail to the top once again.
  - Add water to the five-gallon pail, keeping track of how much you can fit in before it overflows.
  - If you can add 2-1/2 to 3 gallons of water, you have adequate free air space. If not, you need to add more bulking material, such as straw, coarse wood chips, or shredded bark.
  - If you can add more than 3 gallons of water, you have too much free air space. The particle size must be reduced by shredding or grinding the compost materials or by mixing finer materials into the compost.
  - Retest new mix.

### ***Does Your Manure Bedding Mix Require Additional Water?***

Optimal starting moisture for composting is between 50 and 60 percent. Fresh manure alone will be at the optimal moisture level for decomposition. However, the addition of varying amounts of dry bedding, even with urine, can reduce moisture substantially. Additionally, time spent in a storage area in the middle of the summer can reduce moisture even further. Composting in the dry summer season will inevitably require additional irrigation, but you can reduce that need by being certain that your starting moisture is correct. The following is a simple method to determine the moisture in your manure-bedding mix.

Using any reasonably accurate weighing device, weigh out a full 1 or 2 gallon bucket of the mix. Record this as the “fresh” or “wet” weight of the material.

Depending on your preference-tolerance level, select a means to dry this material. Obviously an oven is the best choice (but only the most dedicated will bake a manure cake!). The material could be placed near a hot water heater, in a greenhouse, or anywhere that will assure that the majority of the moisture will evaporate. Re-weigh the material and record this as the dry weight. Calculate the moisture content on a dry weight basis:

$$\frac{(\text{Wet wt.} - \text{Dry wt})}{\text{Dry wt}} \times 100 = \text{Moisture \%}$$

### ***What Compost Method Is Best For You?***

If you talk to enough experienced composters, you may find that each one adheres to their own “best method”. Composting is both art and science, a balancing act so-to-speak. You will soon discover that the appropriate composting method is determined by the realities and size of your site, the number of horses, the type of equipment and labor you have available, the intended use of the final product, and many other factors specific to your needs or goals. The following section describes some basic composting methods that can be applied to any size project. You will find helpful tips on deciding the appropriate compost method or technology that fits the scale, available equipment, and costs specific to your site.

#### Aerobic Thermophilic

This is the composting method assumed and described by many technical resources and guides. The approach requires that oxygen availability is managed to provide optimal conditions for predominantly aerobic (oxygen requiring) microbes. The term thermophilic refers to a group of fungi and bacteria that are so active in breaking down organic matter, that they create significant quantities of heat. These microbes are capable of functioning in temperatures up to approximately 160-165 degrees F. Their oxygen demand is quite high and thus this method requires your manure-bedding mixture to have the optimal physical characteristics that promotes rapid infiltration of oxygen and rapid loss of carbon dioxide.

Aerobic composting methods also require additional management to assure not only adequate oxygen levels, but exposure of all of the composting material to the thermophilic temperatures (>131 degrees F)(CIWMB Website). Therefore additional aeration is often required. This method may utilize your back and shovel or garden fork, a front-end loader, a specialized compost turner, or a system of manifolds, pipes, and blowers (active aeration or aerated static pile method, *see On-Site Composting Case Studies*).

The numerous advantages of this method are:

- ✓ Most pathogens exposed to thermophilic temperatures for periods of 24 hours to weeks at a time are destroyed;
- ✓ Decomposition is rapid and volume reduction occurs quickly;
- ✓ And less time and space are required in comparison to slower methods.

Excessive aeration can lead to large losses of nitrogen as ammonia gas and lower product quality. Piles must be built to an appropriate size that retains (insulates) heat, but not so well that temperatures rise so high as to allow for spontaneous combustion. Compost fires can occur when piles or windrows are too large (overly insulated), not aerated frequently, and when moisture levels decline below 35 percent.

The aerobic thermophilic method is often the preferred method for producing a safe and valuable compost product capable of a wide range of uses.

### Anaerobic Composting

Composting can also be accomplished without efforts to maintain aerobic conditions. In reality, even in an aerobic compost pile, there is a significant amount of anaerobic decomposition occurring. However, the major by-products of completely anaerobic decomposition are different than those produced by aerobic composting. More methane (CH<sub>4</sub>) is formed than carbon dioxide (CO<sub>2</sub>) and ammonia levels (inorganic nitrogen) tend to increase in proportion to organic nitrogen forms. A wide range of other occasionally objectionable odors like hydrogen sulfide and other organic compounds are formed.

Nonetheless, anaerobic composting may be attractive in certain situations. The advantages include less time, equipment, and associated costs than with maintaining aerobic conditions. Although the time required to complete anaerobic composting may be longer than the aerobic process. There will be less or no reduction of microbial pathogens, fly breeding, or parasite eggs, and there is a greater potential for odor generation. Space requirements will be greater due to longer composting time and the product may be less acceptable to certain users. For these and other reasons, anaerobic composting is not recommended.

### Vermicomposting

This “passive” composting method adds earthworms, or more specifically manure worms, to a manure-bedding mix. Horse manure has been a choice “food” for bait worm producers and the product derived from vermicomposting has advantages over “traditional” aerobic composts. Vermicomposting allows constant additions of fresh material to the pile or windrow. The process must remain largely aerobic and high temperatures must be avoided. Therefore, piles, windrows, or beds must be small enough to allow any accumulated microbial heat to be lost quickly to maintain a favorable habitat for worms. The worms best suited for this method are manure worms or red wigglers, naturally found in organic matter rather than soil. They reproduce quickly in large numbers and don’t mind being “crowded” as long as fresh food, moisture, and oxygen are adequate.

The advantages of vermicomposting include:

- ✓ Minimal amounts of equipment are required;
- ✓ Aerobic conditions assure limited odors;
- ✓ Fresh manure can be added daily, weekly, or monthly;
- ✓ Volume reduction may be as high as aerobic thermophilic methods; and
- ✓ The final product has a higher fertilizer value and smaller particle size than typical composts, and is very acceptable for a wide number of uses.

Unfortunately, pathogen reduction may be not as great or consistent, space requirements may be excessive, and compost piles or windrows may need to be covered or lined. Initially worms must be purchased. Worms can be quite intolerant of excessive moisture and even noise. Mass migrations out of compost piles occur and the worms are a favorite food of many below- and above-ground predators.

*For more information of these basic composting methods, please refer to list of references supplied in this guide or contact your local RCD, NRCS or Farm Advisor for technical information.*

### 3.3 Size of Operation Determines Site and Technology

You should consider the following factors when determining whether composting is appropriate and what method and technology is right for you:

Size - There must be adequate space available to handle the anticipated volume of manure and bedding while providing equipment access and work space. You should consider accommodating an area large enough for active composting and temporary storage of final compost product.

Permit Requirements - If you have a large operation, you should check with your local enforcement agency or planning department to confirm permit requirements for a compost operation. More than likely you will at least need to submit a manure management plan and keep minimal records (although current State regulations state that more than 500 cubic yards of material on site at one time or more than 1000 cubic yards produced per year will trigger the need to obtain a permit for your composting operation) (CIWMB website). A larger stable will likely already have some type of operating permit that allows for composting as a manure management alternative. If not, be prepared to educate your local agency and demonstrate that you are aware of and will maintain strict management controls to protect the environment and the interests of your neighbors. California state composting regulations are contained in Title 14, Division 7, Chapters 3.1 and 5.0 of the California Code of Regulations. For operations employing the aerated static pile method, installation of electrical service and equipment may require additional submissions and inspections.

Site Requirements - Your site must not only be sized appropriately, but the operating surface should allow year-round access and minimize the risk of leaching into groundwater. Bare soil is usually not acceptable unless it is a fine clay that can be compacted well and does not receive heavy rainfall for long periods of the winter. Typically, a low permeability crushed rock or rock dust surface, and concrete or asphalt pads may be required. The site or pad should be on flat ground or a very gentle slope and allow for uniform drainage. Runoff from the site should be contained or conveyed to a settling pond or vegetated filter strip. The site should be a minimum of 100 feet from surface water bodies or located downhill from a water body. The site should not create “viewshed” issues for neighbors and minimize complaints about odor and dust. Figure 2 gives an example of some of these site details.

Water Supply - Access to water for moisture management and fire safety during the dry season is essential. Water quality should meet the minimum standards for crop irrigation. If you are unsure have your water source tested.



*Access to a water supply is critical when locating a compost site.*

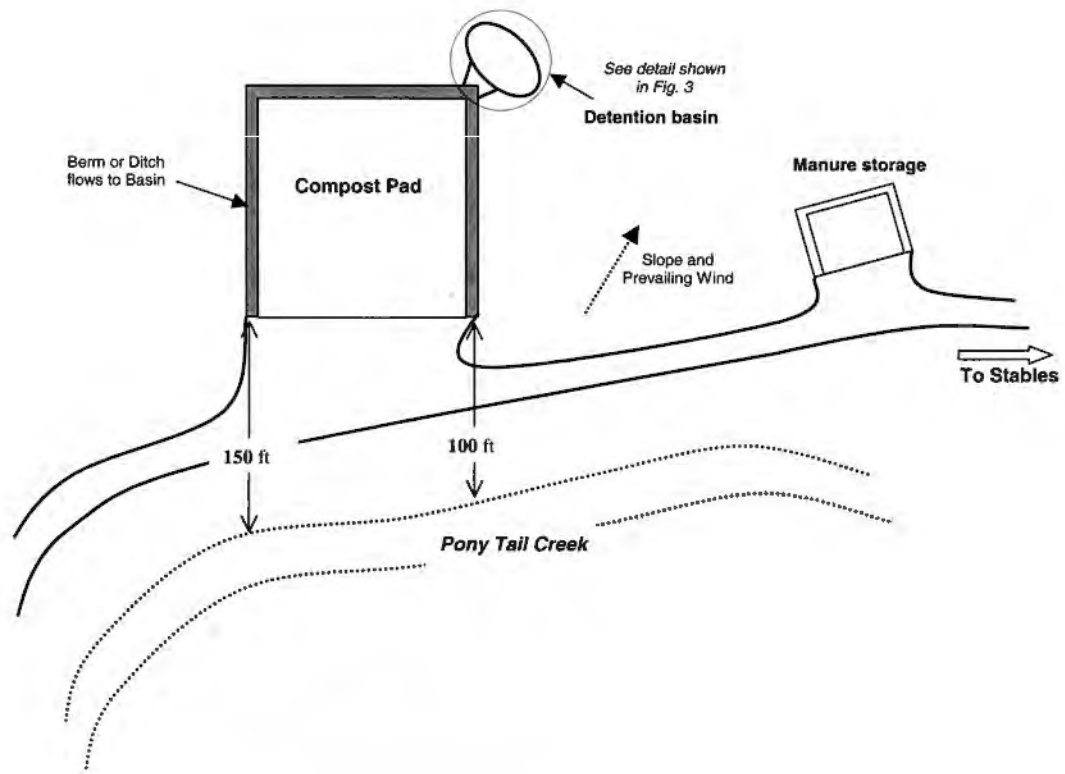

**Figure 2.** Example of idealized compost site details

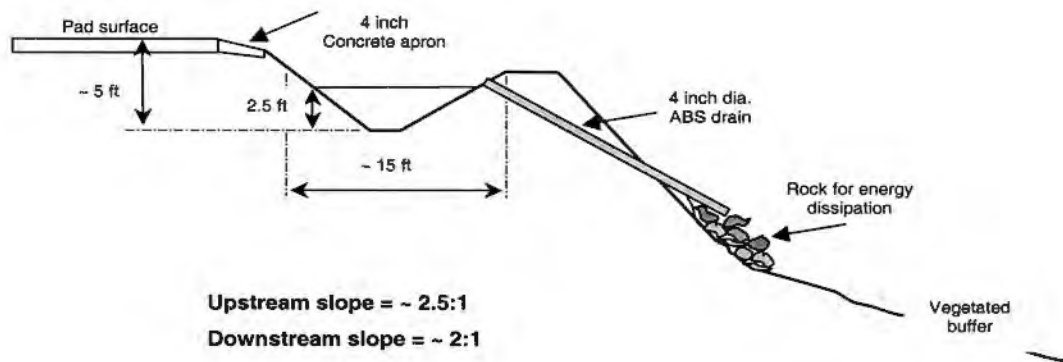

**Figure 3** Cross-section of an idealized detention basin

### ***Compost Technologies and Management***

There are several ways to design an on-farm composting system and no single one is appropriate for all sizes and types of facilities. However, any system should consist of the following basic components:

- A staging or storage area for raw manure, away from creeks and drainage;
- A set of bins or free-standing piles large enough to maintain elevated internal temperatures;
- A mechanism for turning the piles or moving the compost from bin to bin, such as hand labor for small operations or a front-end loader for larger areas; or
- A designed active aeration scheme utilizing manifolds and blowers; and
- A water faucet or a pump/water tank combination, and a spray nozzle.

### **Bins**

For small operations, constructed compost bins may be the appropriate approach (Figure 4). A series of bins may be necessary for the one horse operation and can be scaled-upwards (within reason) for operations with less than five horses. Size of the pile does matter. Bins 4' x 4' x 5' tall, constructed from 2" x 6" (untreated) boards and heavy-duty posts can be adequate; however, bin design and dimensions will vary with amount manure generated (Figure 4). Some have even used pallets as a material to construct bins. Bins with a wooden floor with small spaces between boards that allow air to move from underneath the pile perform better than bins built directly on the ground. Laying flat drain tile on the wooden floor will further enhance air-flow. Each of these bins should easily hold 1.5 tons of horse manure. When aeration is needed, the material is moved from one bin to another. If your horse manure fills up more than six bins of this size or slightly larger, you may want to consider a windrow composting system.

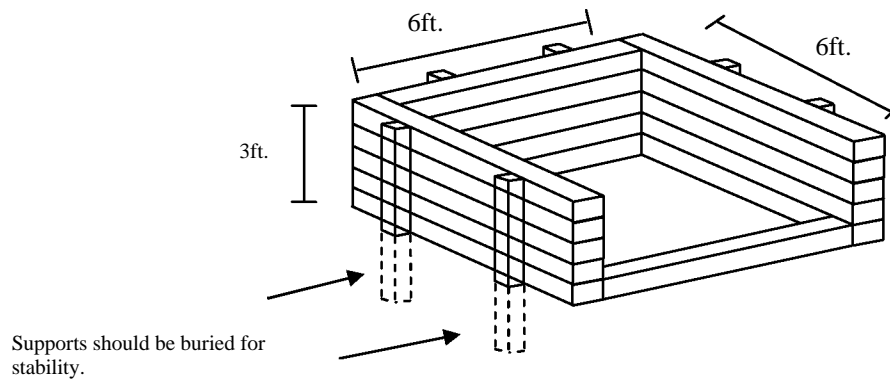

**Figure 4.** General design for horse manure compost bin

### Windrows

For larger operations, a windrow approach will be the most appropriate means to perform aerobic thermophilic composting. Generally, these windrows or piles should be no more than 7 to 8 feet in height and may be of any length that fits with the volume of material generated and the operational preferences of the owner/manager. Windrows and large piles require equipment capable of moving larger quantities of materials. Many stable operations will already have a front-end loader. Dedicated compost turner staff are only appropriate when the quantity of manure is quite large (perhaps > 100 yards per week) and the cost can be reasonably recouped through compost sales or lower disposal costs.

### ***Managing the Compost Process***

The critical operational requirements are related to aeration, moisture management, and process monitoring.

### Aeration

If you choose to employ an aerated static pile system, you will likely need to refer to established engineering and design criteria. At worst, you may need to hire a mechanical engineer to properly size the system. This is critical to be assured that your active system distributes air evenly throughout the entire composting mass and does not introduce too little air (increased anaerobic locations) or excessive quantities of air while removing too much internal heat, or forcing ammonia from the pile.

When utilizing the turned aerobic method, establish a desired turning frequency of 2 weeks, 3 weeks, or monthly. However, if your operation is large enough to require a permit, you will need to establish a turning frequency in accordance with established pathogen-reduction procedures (CIWMB website). Consulting other folks' "rules of thumbs" may get confusing. Remember that composting can often be very site specific. Be prepared to observe and adjust turning frequency as needed. Ultimately this requires time and cost, so you should strike a compromise between an optimal aeration frequency and the other tasks and labor required at your site. However, you should recognize that there may be times (e.g., following heavy rain-fall) when you may need to aerate, regardless of your schedule.

Turning of compost, whether by back and shovel or mechanical loader, should be done in a manner that allows as much air to be introduced to the material as possible. Realize that you are also attempting to release trapped carbon dioxide and reduce compaction at the same time. Therefore, be certain to allow material to “fall” from your shovel or bucket to expose as much surface area as possible. With a loader, drop the material into the bin or new windrow from the maximum bucket height. With a shovel, give it a good toss.

### Moisture Management

The moisture content of the manure and bedding might be adequate in the fresh state, so additional moisture might be unnecessary until the compost is moved or turned. However it may be necessary to add water to the material prior to loading it into a bin or building a pile or windrow. During the dry season, particularly mid- to late summer, have an ample water supply and pressure to “irrigate” the compost as it is turned or moved to another bin. Moisture content can drop as low as 25 percent within 4 weeks of active thermophilic decomposition. To increase the moisture content of compost from 25 percent to 55 percent, add about 20 to 30 gallons of water per 100 cubic feet of compost. For a system in which four bins (1,000 cubic feet each) require additional moisture, approximately 1,200 gallons of water may be needed every time the bins are turned. However, the actual amount of water needed will vary substantially depending on the kind of bedding used, the size of the particles in the bedding, and other site specific factors.

Don’t try to add all the water at once. Instead, use a spray nozzle to deliver the water to the compost as each loader bucket is turned into the bin or new pile. It is easy to verify the proper moisture content. Grab a handful of compost that has been mixed well and squeeze the compost tightly in your fist. You should not be able to squeeze any free water droplets out of the compost, but it should leave your hand slightly wet. If you inadvertently get the compost too wet, don’t panic; just keep an eye on the compost temperatures in that bin and turn the compost if temperatures do not rise in a couple of days. If rank odors emanate from any of the bins, the moisture content is probably too high. Turning the compost will help drive off some moisture, while increasing oxygen and alleviating the problem.

### ***Monitor Compost Temperatures***

Checking compost temperature is the easiest and quickest way to keep track of a composting system. Typically, fresh materials will heat up within 24 hours and within 2 to 3 days of correct construction internal temperatures may reach 155 degrees F. A simple long-stemmed thermometer (or two) and



*Temperatures should be recorded from a number of locations within the compost pile.*

some good record-keeping skills are all that are needed. At a point perhaps two feet down from the top of your pile or bin, carefully insert the thermometer halfway into the side of the composting mass and allow the needle or digital display to stabilize. Record the date, time, bin or pile number, location within the bin (e.g., center, northwest corner, etc.) and temperature. Take

temperatures at several locations to average out any odd readings. Sometimes a thermometer will be inserted directly into a cold or wet spot that is not visible from the outside and is not characteristic of the windrow or bin as a whole.

When you are just getting started, measure temperatures at least daily for the first week after the compost pile or windrow is constructed. Then, if temperatures are in the thermophilic range (between 131 degrees and 160 degrees F), the time between measurements may be increased. Twice-weekly intervals are probably appropriate. Declining temperatures early in the composting period likely indicate declining oxygen levels, less than optimal moisture content, or in the worst case inadequate available nitrogen for the microbes. Temperatures immediately after turning and wetting may drop to near air temperature, but they should rebound markedly within 48 hours. The thermophilic stage of decomposition may last for 2 to 6 weeks depending on the starting C:N ratio. Manure containing the proper balance of shavings or sawdust tends to maintain thermophilic temperatures longer than manure alone or with low volumes of bedding, whereas manure with too much bedding can cause temperatures to drop. Keep the temperature data in a handy file to help document to your local enforcement agency and prospective buyers that weed seeds and pathogens will not be a problem in your compost.

### ***When Is That Compost Done?***

Typically, when utilizing the aerobic thermophilic composting method, temperature is a key indicator of progress towards finished compost. A standard rule of thumb suggests that compost is finished when there is only a 15 to 20 degree difference between internal pile temperature and the air temperature in the middle of the day. Generally, aerobic composting has three distinct phases: the active, high decomposition phase (thermophilic, 2 to 6 weeks); a slower decomposition phase, (mesophilic, 3 to 12 weeks) carried out by different microbes; and then a curing or finishing stage (4 to 8 weeks), where subtle changes in the biology and chemistry of the compost occur. This last phase creates “mature” compost.

Mature compost is that granular, dark brown, earth-smelling material that we associate with potting soil or other “out-of-the-bag” soil mixes. Compost maturity is extremely important for horticultural and agricultural users who may have interest in receiving or purchasing your compost. While there are commercial test kits and laboratory services available, common sense can also be your guide in determining if your compost is finished.

### ***Laboratory Analysis of Compost***

Many users of compost are interested in levels of nitrogen, phosphorus and potassium, total salts or salinity, organic content and, in some cases, micronutrients such as iron or zinc. If your manure management plan includes marketing or giving away the final product, it may be beneficial to have a laboratory analysis of your compost completed from time to time.

## **3.4 Composting Economics**

Maybe you love the idea of making compost and are willing to take on the extra labor and costs to make it happen regardless of economic return. However, if you are not quite convinced, assessing the economics of composting is a good pre-project task. There is no standard guide, as composting economics often come down to the specifics of your operation. Some things are readily apparent at the outset. The purchase of a \$30,000 loader for your one horse in the back

half acre makes no sense, unless you become an equipment operator for hire. If you operate a large stable, you probably already have such equipment. And if you are currently paying to haul your manure to a landfill, you already have a significant cost associated with manure management that could be substantially off-set by producing and marketing compost. The amount of manure and bedding that you must manage is key to determining how cost-effective your composting project can be. Economy is dictated by scale and typically the costs per ton or cubic yard of compost goes down as the volume of manure and bedding generated goes up.



*Trucking is the major cost in manure management.*

If you are a one horse show with some room and a willing and strong back available, you may only need capital costs for site development and bin construction. If you have a large garden or pasture, you can probably utilize all of each year's compost from your animal's manure and bedding on your property. However, for larger stables there may be significant costs involved for site development, equipment, provision of water and/or electricity to the composting site, and labor. The owner/operator should seriously consider if the costs make sense for the operation. Consider the "avoided" costs associated with composting. How much does trucking and landfill fees cost per year? Compare that to the composting startup costs, including the items mentioned here. Can you save money after considering amortization/depreciation of purchased equipment over five years? Consider marketing your product as another cost offset. Survey the current prices paid for organic soil amendments or mulch materials in your area. Do your math and decide if composting makes both environmental and economic sense for your operation. Additional economic information may be obtained from your local RCD office.

### **3.5 Composting Summary**

You've made it through this brief lesson in composting. Below are some rules to consider and "live by" before and after you become a composter.

- ✓ If you manage a larger facility, be prepared to spend some time educating your clients about your goals for manure management with composting.
- ✓ Prepare your site to ensure the compost area drains well. Ponded water, especially around manure and compost, will cause odor and fly problems. A small box blade or the back of your loader will help keep the area smooth and well drained.
- ✓ Collect manure from the corrals and pens carefully. Try to keep mineral soil out of the manure, and keep track of how many wheelbarrow loads are delivered to your system every day. Try to limit the amount of woody bedding materials that end up mixed with manure.

- ✓ Try to ensure good drainage from any outdoor horse pens from which manure is collected. Muddy conditions give you soil-laden manure, reducing the organic matter content per unit of compost. Instruct employees to keep garbage, plastics, carcasses, and animal health products (syringes, vials etc.) out of the compost piles.
- ✓ Make provisions for adding supplemental water when needed. Shaping the tops of the piles to capture irrigation or rainfall may be helpful.
- ✓ Monitor compost temperatures every few days initially and at least weekly. Temperature alone will not tell the full story, but it can be an indicator of success or of imminent problems.
- ✓ Keep the composting area clean and well maintained. If you have a boarding operation, a good image is vital to ensuring your clients' cooperation and for compost marketing success.
- ✓ Use the finished product in your own landscapes, planters, and gardens. If you use it and like it, your clients will be more inclined to try it.
- ✓ Have laboratory analysis performed on compost samples from time to time. Knowing your product will reassure your compost market and will help you identify ways to improve your system. A routine analysis will include nitrogen, phosphorus, potassium, sulfur, and total salinity. Organic matter analysis adds significantly to the cost, but it will help you determine if manure-harvesting methods are picking up too much mineral soil, which reduces compost quality. If interested in using compost as a bedding material, periodic analysis for pathogens is good insurance.
- ✓ Compost has a value; carefully consider what makes sense to you before you give the compost away. A nominal fee will stimulate interest and the revenue will offset costs.

#### **4. ON-SITE COMPOSTING CASE-STUDIES**

Four case studies of compost projects undertaken in the Bay Area are presented below. The case studies are intended to be a guide as to what might be undertaken at your facility to compost horse manure. For further information consult one of the RCD's listed at the end of this publication.

##### **4.1 Case Study #1:**

###### ***Site/Facility Description***

This stable boards 30-40 horses and worked with their local RCD to construct an aerated static pile composting system.

###### ***Composting System***

The equine facility has constructed a compacted, low permeability gravel pad on which horse manure is managed and composted. The pad measures approximately 88 by 115 feet. It has a

compacted subsoil base, overlain with Mirafi 500x moisture barrier fabric and topped with 4-6 inches of compacted well-graded crushed rock (i.e., road base). The pad has a slope of approximately 2%, which drains surface water runoff into an adjacent vegetated filter strip.

The manure is composted using the Aerated Static Pile (ASP) method, a procedure that was originally developed by the U.S. Department of Agriculture in the 1970s. The system consists of a blower connected to a manifold with a series of four lateral perforated pipes approximately 45 feet in length. The manifold and perforated pipe system sits on the gravel pad and the manure is piled on the perforated pipes. When completed, the manure pile measures approximately 50 feet long by 20 feet wide by 6 feet high, with an initial volume of approximately 200 cubic yards. This represents approximately 30 days of waste for this facility. The blower serves to force air through the manure pile to expedite aerobic decomposition of the manure. The project design incorporates two adjacent manifold systems (systems A and B) that have been constructed to allow for stockpiling of fresh material on one system (B) while manure on the other system (A) undergoes aerobic composting.

After approximately 30 days, the manure pile at system A has completed aerobic composting. Stockpiling of fresh manure at system B over the month is also complete. The manure pile at system A is moved to a third location on the constructed pad to cure. A layer of this composted material approximately 1 foot deep is placed over the manure pile at system B to serve as an insulative cover for temperature retention and as a biofilter to control odors. The blower is then connected to system B to begin aerobic composting, and the landowner begins piling fresh manure at system A. The composting system cycles between system A and system B in this fashion. During the rainy season a waterproof barrier is maintained over the manure piles to prevent compost leachate from reaching any adjacent water bodies.

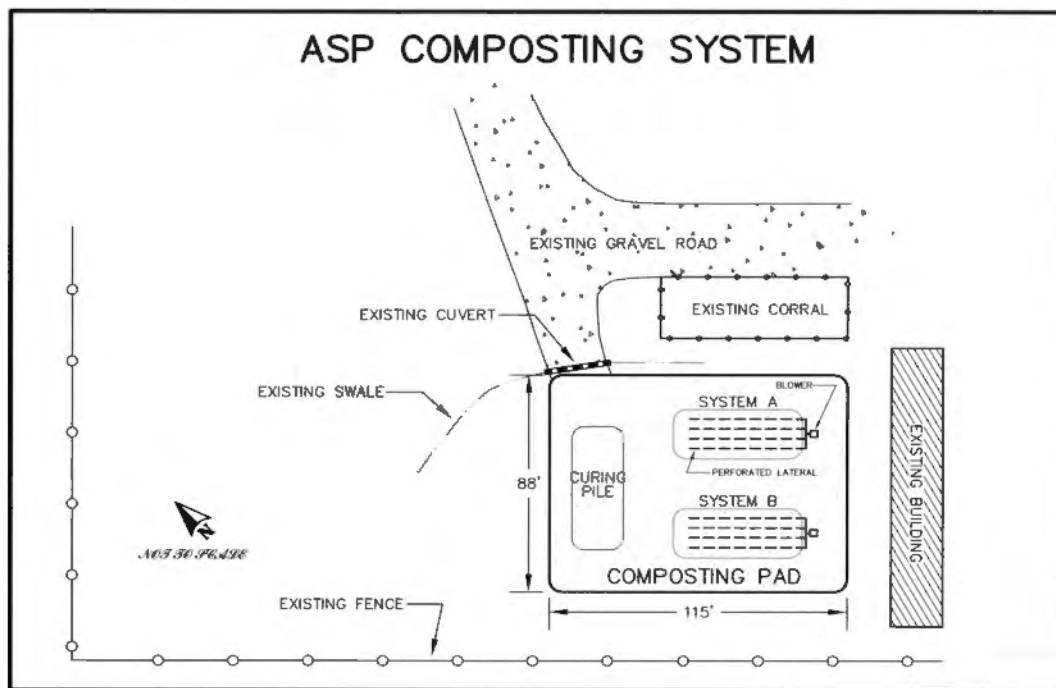

The project landowner is currently using much of the compost as a high quality mulch in their landscaping beds. A marketing plan is also being prepared so that the composted manure can be sold for agricultural or landscaping purposes.

#### ***Prior Manure Management Methods***

Prior to implementing the composting system, the landowner was stockpiling manure, either giving it away to other landowners or spreading on the open fields of the facility.

#### ***Evaluation and Comments From Owner/Manager***

The landowner feels that the end product is very usable and good for the environment. There has, however, been an increase in labor and energy costs. The composting project has controlled the odor problem completely and is not attracting flies. The landowner summed up by stating that they will have a salable product that will not only offset costs but produce a small amount of income once they've located some buyers. Even with only using the product as a mulch on-site, it is worth the cost savings of no longer having to buy mulch for the facility landscaping.

### **4.2 Case Study #2:**

#### ***Site/Facility Description***

The local RCD provided technical assistance on a composting project, in conjunction with the facility's expansion plans. The proposed site was adjacent to an existing stormwater holding pond and approximately 100 feet from a creek. Barns and stalls are 100-300 feet from the compost site. The site was first cleared of all existing manure and graded so that all surface runoff would drain across a grass filter strip toward the holding pond. A berm along the creek side edge of the site was established to prevent runoff into the creek, and a horse trail to the creek was seeded, strawed, and wattled. The composting pad was surfaced with gravel to permit wet season use. Regrading and surfacing the main roads into the facility were completed and old, non-functional ditches and culverts were repaired or eliminated. Gutters were added to the roofs of a covered riding arena and a few older barns so that the clean roof runoff was channeled to energy dissipating rock rip rap above the creek. This significantly reduced the volume of clean water going through the manure compost site and into the holding pond. Unfortunately, local regulations required channeling the clean roof water into the holding pond through a grassed swale which subsequently required enlargement of the holding pond.

#### ***Composting System***

Composting began in the spring of 1999. A small loader proved inadequate to handle the volume of manure and bedding and turn the windrows. The waste material also has a higher than desired percentage of bedding. Purchase of a larger piece of equipment was not feasible for the stable. Effort was focused on monitoring pile temperatures, moisture and pile configuration to keep the site in an orderly condition and optimize the resulting passive composting process. The finished product is less than desirable due to the high carbon content (undecomposed shavings) and does not meet the criteria for finished compost at the end of the process. The compost is periodically trucked off site to a local farm.

#### ***Prior Manure Management Methods***

At the time of project initiation, the facility had recently changed hands. An existing drainage

system diverted potentially contaminated surface water through the manure storage area to the holding pond. The pond was subject to local county monitoring and provided habitat for amphibians, invertebrates and migratory waterfowl. The site was used for manure storage and overflow parking for horse trailers and other vehicles. The site was poorly managed and standing water contaminated with manure from winter rains was a problem. Manure volume held at the site averaged 2,500 cubic yards. A horse trail dropped steeply from the site to the creek.

### ***Evaluation and Comments From Owner/Manager***

Overall the operator is pleased with the compost system. Their intention to develop a compost system was a win-win situation as the facility, RCD and County learned from the project. The facility benefited from an ability to hold material on site for longer periods of time due to a 50% bulk reduction resulting from composting of bedding and manure, off-site hauling costs were reduced from up to twelve times a year to two times a year, the facility was able to use a greater volume of finished product on-site, and the project resulted in the facilitation of a good relationship with the County and community. Involvement with the County and RCD helped give the project transparency and credibility. In short, the project demonstrated the owner's commitment to operate the facility in an environmentally responsible manner.

The costs of the compost operation and compost disposal remain a concern. Increased management costs and labor may make the business of manure handling and compost marketing unrealistic for most equestrian facilities. An additional 4-8 hours weekly of labor plus management are needed to operate the facility. The cost of purchase or rental of needed equipment such as a one cubic yard front end loader, manure spreader, and trailer or truck for transporting or aiding in spreading the compost may be unfeasible. The high visibility of the compost site for clients entering the facility is somewhat problematic and may be addressed by landscape plantings to better screen the site. Due to the small size of the equipment, it may be better to have a second compost site closer to some of the stalls. Other options include purchase of a used front end loader, use of a nitrogenous additive to improve the C:N ratio of the raw materials, and incorporation of a forced air system.

The attention garnered by this project and outreach efforts by the RCD have resulted in interest from other stables, horse keepers, other farmers and the county to investigate the feasibility of a regional composting facility where costs of equipment and transportation of manure might be spread across a number of facilities. A demonstration of such a cooperative facility is being proposed.

### **4.3a Case Study #3:**

#### ***Site/Facility Description***

In Alameda County, a 70-horse boarding and training facility is experimenting with composting approximately 10% of its horse manure, roughly 150 cubic yards annually, using the passive aerated composting method. The manure (and wood shavings bedding) is being composted on a 20' x 50' pad located in a nearly flat grassy pasture (1-2% slope) adjacent to

the barn and horse stalls. The soil at the compost site is a deep gravelly loam (72") and the water table (at its highest level during winter months) is at 20'. Because of the potential for groundwater contamination, runoff and leachate from the compost pile need to be managed. The compost system was designed to protect groundwater and surface water primarily by managing the amount of rainfall that reaches the manure through use of a type of tarp to cover piles that allows the passage of air, but is water resistant. "Clean" runoff from each tarp drains to the graveled sides of the compost pad and then flows just down gradient to a portion of the pasture that functions as a grass filter strip and runoff infiltration area. The filter strip traps any stray particles of manure and utilizes any nutrients that may be present in the runoff.

Leachate, the enriched liquid which can drain downward from a saturated compost pile, will be produced in minimal quantities in the compost windrow because of monitoring of the moisture level of the compost material; when piles have reached the maximum moisture content from winter rain or summer watering the tarps will be put over the piles. Any leachate draining from the pile will be blocked from percolating downward into the soil beneath the compost pad because of the moisture-proof PVC liner (.03" thick) that was sandwiched between the two 6" layers of compacted crushed rock (road base) which comprise the compost pad.

### ***Composting System***

The passive aeration system of composting utilizes perforated pipe to bring air into the compost pile. At the compost site, the manure was piled onto the rectangular 50' x 20' compost pad in a 2' thick layer. PVC pipes 20' long and 4" in diameter with two rows of ½" holes running the length of the pipes (these are the pipes used for septic tank drain fields) were placed several feet apart on top of the manure, across the 20' width of the pile. Four to six feet of manure was then loaded on top of the pipes. The ends of the pipes project out from the sides of the pile, taking in air, which flows out through the rows of holes inside of the pipes into the manure, thereby aerating the pile through a "chimney effect". The composting method used at the site is termed "static aerated" because the windrow is aerated without turning or use of blowers. This method requires minimal labor and equipment, but the composting process may take longer. Temperature and moisture-level monitoring is done on a weekly basis and this will dictate whether tarps are needed. The tarps are also effective when moisture needs to be conserved in the piles during the dry, hot summer months.

When compost is ready to undergo the curing process it will be moved to an adjacent space in the pasture; a reduction in volume of material of 30-50% can be expected. Compost is utilized at the ranch as a soil amendment to improve the fertility and water-holding capacity of the soil for the landscaping purposes. It may also be utilized by nearby vineyards and for winery landscaping.

### ***Prior Manure Management Measures***

Previous to the experiment to compost manure on-site, manure was hauled out to be further composted with grape pomace for use in a local vineyard.

### ***Evaluation and Comments From Owner/Manager***

The facility owner is familiar with composting and wished to experiment with the process on-site. The owner also looks to expand tree plantings at the ranch, and needs the compost for a soil amendment. The owner also wants to participate in conservation activities and to demonstrate water quality management techniques. If the composting project is successful and cost efficient, the pad will be expanded and a greater percentage of the facility's manure will be composted.



This compost method uses perforated pipe to bring air into the center of the windrow. Portable fencing keeps cattle out.

### **4.3b Case Study # 3**

#### ***Site/Facility Description***

A five acre horse boarding facility, located within city limits and surrounded by a housing tract, is developing a “modular” manure management and composting system using compost bins. Since the facility is planned to grow from less than five to more than 10 horses, the number of composting bins in use will increase as needed. The bins are situated at different points around the ranch where they will be most convenient for loading. They will then be moved, once filled, to different areas of the site for an approximate two month composting period. Compost will be utilized on-site for a native plant nursery, or sold/given away to neighbors in the vicinity.

#### ***Composting System***

The facility owner is using 4' x 4' x 4' wooden bins (originally built for use during almond harvesting) for composting manure and bedding. The bins are very sturdy and constructed in such a way that they can be picked up and moved with a forklift. Daily stall cleanouts are placed into a bin on top of six inches of dry wood shavings that have been placed in the bottom to absorb liquid from the composting manure. Three or four, five-foot lengths of PVC plastic pipe 4" in diameter with two rows of holes drilled down the length are situated vertically in the manure in the bins to improve aeration. When the bin is filled so that manure is piled one-foot above the rim, a water-resistant, breathable tarp is used to cover the bins to help the composter control the moisture content of the manure; once the manure has reached the optimal point of dampness (from rain or watering) the tarp can be deployed to cover the

manure and the outside of the bin sides. The bins can be set onto cinder blocks during the wet season if needed. The tops of the pipes are slightly exposed above the manure, and will ventilate through the tarp. This will also prevent flies from accessing the manure. Pile temperature and moisture level is monitored weekly.

#### ***Prior Manure Management Methods***

When only 2-4 horses were at the site manure was tilled into the soil, and some of the material was used for soil mix for a small native oak nursery at the site.

#### ***Evaluation and Comments From Owner/Manager***

The landowner of this very old, historical ranch which has had horses on it for over 125 years is very interested in developing a small scale, low visibility, modular manure management system which will not impact the surrounding neighborhood visually or with odors or dust. Confining composting manure to small, aerated, movable bins concealed under dark green, non-reflective tarps is a good solution. Additional bins can be purchased and put into use as needed. There may be an experiment in the future with growing edible mushrooms in the bins using the partially composted manure and wood shavings bedding. There may also be a test of wood pellet bedding in the stalls, since this material composts better than wood shavings, and less material is used in the stalls to begin with. The compost is to be used at a native plant nursery at the site and as a soil amendment for plantings around the ranch.

### **4.4 Case Study #4**

#### ***Site/Facility Description***

This stable worked with their local RCD and boards 60-70 horses on site.

#### ***Composting System***

The project is utilizing a concrete pad that formerly served as the floor for a pig rearing facility. The surface is uneven, and in order to have an adequate sized surface an additional 15 x 80 foot section was constructed with a compacted, low permeability crushed granite material. The operating pad measures approximately 80 feet by 80 feet. The pad has a variable slope up to approximately 2%, that drains surface water runoff into adjacent detention ditches and a small holding basin on the southwest corner of the pad. The ditches and basin are constructed with erosion control fabric and gravel. The site is located well out of and above the flood plain of the creek and away from the stables. An irrigation reservoir is located adjacent to the site.

The manure is composted using an aerobic thermophilic process using a front-end loader for turning and aeration. The manure and bedding (wood shavings) is collected at two storage bunkers adjacent to the stalls and paddocks. The storage bunkers have concrete floors with concrete walls on three sides. They are located away from the riparian area of the creek. The mixture is watered daily to ensure adequate starting moisture for composting. Manure is moved on a regular basis (every 1 to 5 days) to the composting site approximately 1500 feet away, where it is added to large piles or windrows that ultimately hold one month's worth of

material. Temperatures are monitored weekly until the compost is removed from the site. In order to minimize costs and loss of nitrogen, the piles are turned once a month. When necessary, water is applied with a 4 HP 2 inch gas pump that draws from a nearby irrigation reservoir. With each turning each month's pile is moved closer to a curing area located just off the main pad. After approximately 90 days of composting the material starts the curing or finishing process.

The active composting phase at this site is rather long due to the use of large quantities of wood shavings, particularly by the owners of show horses. This has been identified as a significant problem by the site facility manager as the long composting period reduces available space on the pad. As an alternative, the manager has begun to experiment with the use of wood pellets as a substitute for shavings. A comparison of composting and final compost quality will be made prior to the end of the demonstration phase of this project. The first product produced at the site is scheduled to be delivered and used by a local vegetable grower. A complete laboratory analysis of the compost will be provided to this cooperating grower. It will include analysis of nutrients, salinity, particle-size distribution, inert contaminants, maturity, and will be tested for the presence of viable weed seeds, heavy metals, and fecal coliform and Salmonella pathogens.

#### ***Prior Manure Management Methods***

Prior to this demonstration project, the facility stored manure on site and then hauled all of its manure to the regional landfill at a cost of approximately \$20,000 per year. Manure from stalls and paddocks was held in a location too close to the creek and could potentially have caused a problem.

#### ***Evaluation and Comments From Owner/Manager***

Thus far the manager is pleased with the potential for this manure management approach. The uneven concrete surface and compacted rock surface have hindered operations to a minor degree. The runoff retention structure has performed well even during a 4 inch rainfall event this winter. The manager sees a potential to both reduce the volume of waste through reduction in bedding materials and composting and reduce trucking costs for final disposal. Once the system is fully operational and all the bugs worked out, the operator believes that there will be an average of 4-6 hours a week of work plus another average of 8 hours a month to turn the compost piles. Time and costs associated with all aspects of this project are being recorded for final cost analysis.

## 5. GLOSSARY

**aerobic** – an organism or process requiring air (sic. oxygen)

**aeration** – to expose or supply with air

**anaerobic** – an organism or process that does not require oxygen

**bedding manure** – a mix of manure and bedding material

**biofilter** – a system that uses soil, organic materials, or living plants to trap unwanted gases, particulate matter or chemicals

**buffer** – any structure, distance, or planting that shields or protects another from danger, loss, or contamination

**composted manure** – manure that has gone through the composting process

**containment area** – a basin or other landscape feature designed to contain leachate or runoff from compost or manure handling areas

**filter strip** – typically an intentionally planted buffer area (grasses most often) that provides a trap for particulate matter and nutrients for runoff waters

**fresh manure** – manure that has been excreted from the horse within the previous 48 hours

**grassed waterway** – a vegetated drainage channel designed to safely carry water and trap sediment and nutrients

**leachate** – water passing through and out of soil or manure that contains dissolved nutrients and organic matter from the material

**microbes** – a microorganism (eg., bacteria, fungi, algae)

**micronutrient** – an element or compound required in only small amounts by animals and plants

**pathogens** – any disease-causing organism

**pathogenic** – disease-producing

**riparian area** – pertaining to the bank area adjacent to a creek, stream, or river

**stored manure** – manure that has been removed from stalls or paddocks and piled in preparation for further processing or disposal.

**RCD** – Resource Conservation District, a non-profit community organization organized as a Special District under California law (Division 9, Public Resource Code) that provides technical assistance for protection and conservation of natural resources

**NRCS** – National Resources Conservation Service, a branch of the United States Department of Agriculture (USDA) and formerly the Soil Conservation Service

## 6. REFERENCES

Land Application of Livestock and Poultry Manure (C.B. Hammond, Segars, and C. Gould) University of Georgia Extension <http://www.ces.uga.edu/pubcd/c826-w.html>

Small Ranch Manual. Nevada Cooperative Extension

Horse Manure Management. (J.G. Davis and A.M. Swinker). 1996. Colorado State University Cooperative Extension

Horse Manure Management. Council of Bay Area RCDs. 2000

Horse-Keeping on Small Acreage: protecting Groundwater and Surface Water. (B. Lamb and M. Sullivan) 1993. University of Rhode Island Cooperative Extension

On-Farm Composting Handbook. (Robert Rynk, ed.) 1992. Northeast Regional Agricultural Engineering Service

Strategies for Livestock Manure Management. Washington State University and King County Cooperative Extension. 2002

A Horse Owner's Guide to Protecting Massachusetts Natural Resources. 2003.  
[www.state.ma.us/dep/consumer/animal.htm](http://www.state.ma.us/dep/consumer/animal.htm)

Composting. Massachusetts Department of Environmental Protection. 2002

Horse Keeping: A Guide to Land Management for Clean Water. Bay Area RCDs. *Available from your RCD*.

Horse Manure Management. (R. James) Ohio State University Extension Fact Sheet (AGF-212-03).

Horse Manure Management-Preventing a Solid Nitrogen Deficiency. (R. James) Ohio State University Extension. Factsheet AGF-212-95 <http://ohioline.osu.edu/agf-fact/0212.html>

Horse Stable Manure Management. (E. Wheeler and J Zajaczkowski) Penn state Cooperative Extension. 2001

Manure Management. Clemson University Cooperative Extension Service. 1994.

Manure Management and Composting. Canadian Organic Growers. 1992

Manure and Pasture Management for Recreational Horse Owners. University of Minnesota Extension Service. 2000.

Spreading Manure on a Few Acres. University of Minnesota Extension Service. 2000.

Managing Manure by Composting. University of Minnesota Extension Service. 2000.

Manure Management for Horse Farms. (J. Gardner and R Wright). Ontario Ministry of Food and Agriculture. 1998

Ohio Livestock Manure and Wastewater Management Guide. Ohio State University. 1992.. Bulletin 604.

Passively Aerated Bunker System for Composting Horse Manure. (D. Shaw). Alberta Agriculture , Food, and Environment. 2002

**Publications and Fact Sheets Available from your RCD:**

An Overall Guide to Land Application of Horse Manure. Dennis Salisbury

Equine Manure Storage Fact Sheet

Equine Facility Site Assessment Checklist

Composting Horse Manure Fact Sheet

Manure Storage for Horse Facilities Fact Sheet

Managing Manure: The Role of Riparian Buffers

Land Application of Horse Manure Fact Sheet

Portable Backyard Garden

Photographic Monitoring

Water Quality Management and Horses

**Web Sites:**

Handling manure as a solid: <http://www.epa.gov/ostwater/guide/feedlots/execsumm.pdf> .

[www.horsekeeping.com/horse\\_management/manure\\_management.htm](http://www.horsekeeping.com/horse_management/manure_management.htm) Manure Management by Cherry Hill.

[www.nps.ars.usda.gov/](http://www.nps.ars.usda.gov/) Appendix F to CNMP show URL for that pg 6

[www.agf.gov.bc.ca/resmgmt/fppa/pubs/environ/horse](http://www.agf.gov.bc.ca/resmgmt/fppa/pubs/environ/horse) Environmental Guidelines for Horse Owners Ch.8. Manure Management

[www.thehorse.com](http://www.thehorse.com)

McDowell, Agsource prepared by Larry Hudson, Extension Animal Scientist. 1998.

“Internal Parasites of Horses”

<http://mcdowell.ces.state.nc.us/staff/mdeluca/pages/horse.shtml>

[www.californiastatehorsemen.com/envirohorse.htm](http://www.californiastatehorsemen.com/envirohorse.htm)

California Integrated Waste Management Board; Compost Regulations  
[www.ciwmb.ca.gov/regulations/title14/ch31.htm](http://www.ciwmb.ca.gov/regulations/title14/ch31.htm)

## **7. SOURCES FOR FURTHER TECHNICAL ASSISTANCE**

### **USDA-NRCS**

Salinas Area Office

318 Cayuga Street, Suite 206

Salinas, CA93901

831-754-1595

925-371-0154

Alameda County

707-794-1242 x 3

Marin/Southern Sonoma Counties

650-726- 4660

San Mateo County

### **County RCDs**

#### **Alameda County RCD**

1996 Holmes Street

Livermore, CA 94550

925-371-0154

[www.baysavers.org](http://www.baysavers.org)

#### **Marin RCD**

804<sup>th</sup> Street, Suite 203

Point Reyes Station, CA 94956

415-663-1170

[www.sonomamarinrcds.org](http://www.sonomamarinrcds.org)

#### **San Mateo RCD**

625 Miramontes St, Suite 103

Half Moon Bay, CA 94019

650-712-7765

[www.sanmateorcd.org](http://www.sanmateorcd.org)

#### **Southern Sonoma County RCD**

1301 Redwood Way, Suite 170

Petaluma, CA 94954

707-794-1242 x 3

[www.sonomamarinrcds.org](http://www.sonomamarinrcds.org)

Attachment 4-  
Horse Keeping: A Guide to Land Management  
for Clean Water

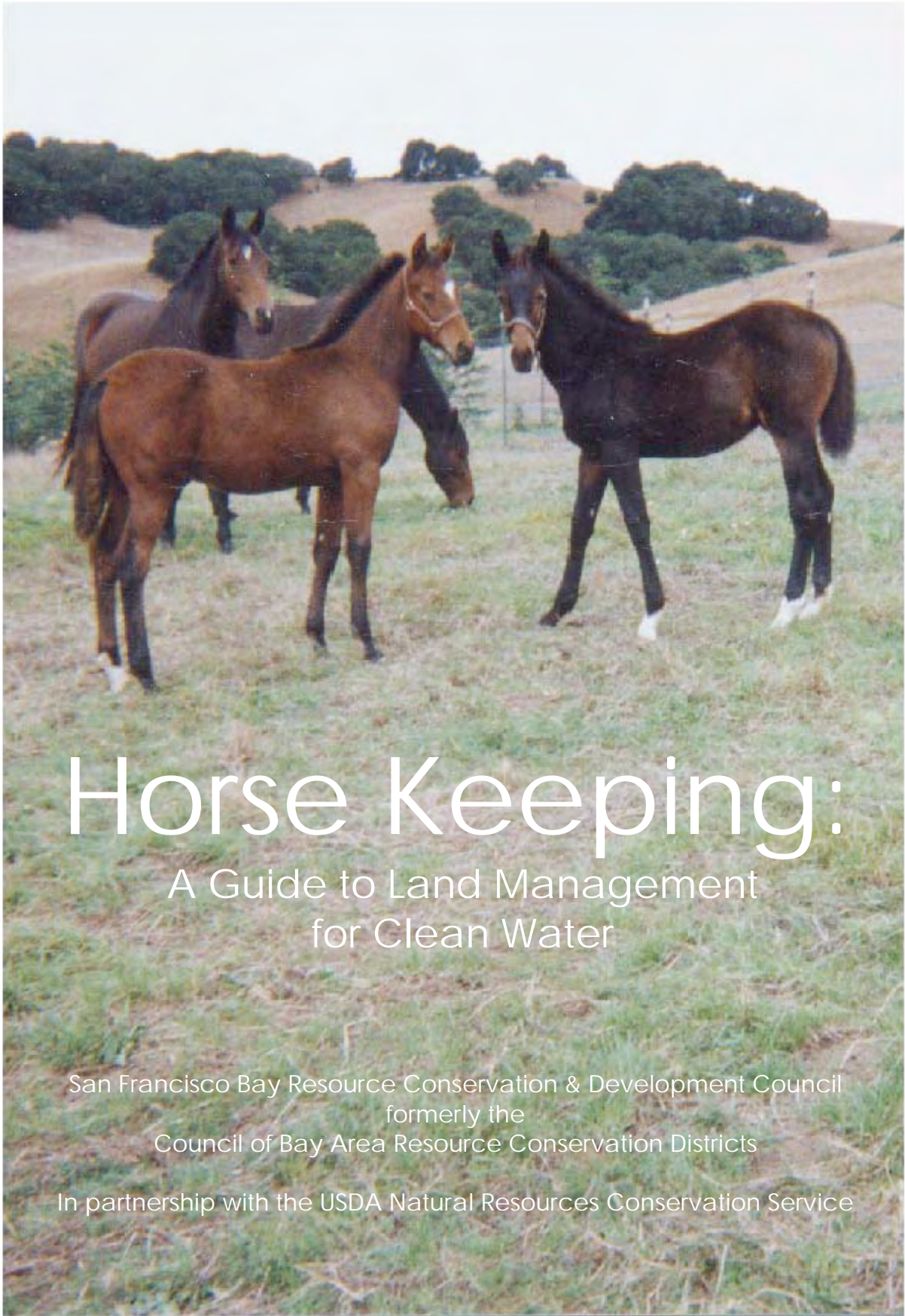

# Horse Keeping:

A Guide to Land Management  
for Clean Water

San Francisco Bay Resource Conservation & Development Council  
formerly the  
Council of Bay Area Resource Conservation Districts

In partnership with the USDA Natural Resources Conservation Service

For more information about ordering this publication, contact:

**San Francisco Bay Resource Conservation & Development Council, (formerly known as the Council of Bay Area Resource Conservation Districts)**  
**1301 Redwood Way, Suite 215**  
**Petaluma CA 94954**

**The Council of Bay Area Resource Conservation Districts (RCDs):** RCDs participating in this project include Alameda County RCD, Contra Costa RCD, Marin County RCD, San Mateo County RCD, and Southern Sonoma County RCD. See Resources Direction, section 5.1 for contact information.

Council of Bay Area Resource Conservation District members include: Alameda Co. RCD, Contra Costa RCD, Guadalupe-Coyote RCD, Loma Prieta RCD, Marin Co. RCD, Napa Co. RCD, San Mateo Co. RCD, Southern Sonoma Co. RCD and Suisun RCD.

Short excerpts may be reproduced with appropriate attribution to the **San Francisco Bay Resource Conservation & Development Council**.

Copyright © 2001 by the San Francisco Bay Resource Conservation & Development Council, formerly known as the Council of Bay Area Resource Conservation Districts

Please cite this manual as:

*Horse Keeping: A Guide to Land Management for Clean Water*. 2001.  
Council of Bay Area Resource Conservation Districts, Petaluma, California.

**We used information from the following sources with permission:**

- Creek Care: A Guide for Urban Marin Residents. Marin County Stormwater Pollution Prevention Program.
- *Groundwork: A Handbook for Erosion Control in North Coastal California*. 1987. Marin County Resource Conservation District. Illustrations used.
- *Home\*A\*Syst: An Environmental Risk Assessment for the Home (NRAES-87)*, published by NRAES, the Natural Resource, Agriculture, and Engineering Service, Cooperative Extension, 152 Riley-Robb Hall, Ithaca NY 14853-5701. (607) 255-7654. <[www.nraes.org](http://www.nraes.org)>
- *Repairing Streambank Erosion*. 1997. Marin County Stormwater Pollution Prevention Program brochure.
- *Stream Care Guide*. 1989. County of Santa Cruz.
- Marin Coastal Watershed Enhancement Project. 1995. UC Cooperative Extension, Marin County. Fact Sheets adapted for use in this guide:
  - *Water Quality Variables and Water Testing for Rural Landowners*
  - *Vegetation Monitoring*
- *Fight Nature with Nature: Environmentally Friendly Insect Control for Horse Farms*. 1999. Alayne Blickle, Horses for Clean Water.

**This project was developed as part of the Equine Facilities Assistance Program, which was funded in part by:**

- United States Environmental Protection Agency Assistance Agreement No. C9-999414-96-1 to the State Water Resources Control Board and by Contract No. 7-028-252-0 in the amount of \$255,000. The contents of this document do not necessarily reflect the views and policies of the Environmental Protection Agency or the State Water Resources Control Board.
- Alameda County Department of Public Works
- Alameda County Resource Conservation District
- California State Coastal Conservancy, Bay Area Conservancy Program
- Marin County Stormwater Pollution Prevention Program

To simplify information, trade names of products have been used. No endorsement of named or illustrated products is intended. Every attempt has been made to assure that the information contained in this publication is accurate. The San Francisco Bay Resource Conservation & Development Council, formerly known as the Council of Bay Area Resource Conservation Districts assumes no responsibility and disclaims any liability for any injury or damage resulting from the use or effect of any product or information specified in this publication.

The U.S. Department of Agriculture (USDA) prohibits discrimination in all its programs and activities on the basis of race, color, national origin, sex, religion, age, disability, political beliefs, sexual orientation, or marital or family status. (Not all prohibited bases apply to all programs.) Persons with disabilities who require alternative means for communication of program information (Braille, large print, audiotope, etc.) should contact USDA's TARGET Center at 202-720-2600 (voice and TDD).

To file a complaint of discrimination, write USDA, Director, Office of Civil Rights, Room 326W, Whitten Building, 14th and Independence Avenue, SW, Washington, DC 20250-9410 or call (202) 720-5964 (voice and TDD). USDA is an equal opportunity provider and employer.

Cover Photo: Oldenberg colts at Hawkwood Hill Farms, Sonoma County

## Preface

**T**HE HORSE HAS BEEN THE FUEL that stoked the fires of progress in time of peace and war throughout the centuries. When the need was greatest in the building of a new nation, or to carry supplies in time of war, the horse and mule responded to the call.

The horse has served as the early day equivalent of a tractor. They were our first example of rapid transportation and a true dependable friend. When all else failed they would be the food that served the top, or the bottom of the food chain.

The surge in population during the last century, with its need for increased quantities of water, along with the diminished status of the horse, has created a situation where the needs of our horse industry has become secondary and we have ended up with little political power.

*So, understanding that the demographics have changed is tantamount to effecting change. Water was once a surplus commodity, is now in great demand and is the subject of lawsuits up to and including the Federal Government. Everyone wants “their share” of a safe, guaranteed-supply commodity.*

The water we drink and the fish we eat require clean water, so cleaning up and maintaining available supplies of water is a job for all humanity.

The Council of Bay Area Resource Conservation Districts (RCDs) has prepared this manual as a road-map to help us be a *volunteer part of the solution, rather than a part of the problem*. Many times we see “edicts” handed down where industry has little or no input. In this undertaking the RCD is saying, “Here are graphic examples of typical problems and we would like to work with you to solve yours.”

The time to look at your operation is now. The window of opportunity is open For us to manage our properties in a way to minimize or eliminate pollution. If we wait to see what happens, laws *will* be enacted that require us to make changes that may seem unfair and questionable.

*Ken Brown  
California State Horsemen’s Association*

## Preface

**L**AND: THEY AIN'T MAKIN' IT ANY MORE, so said Will Rogers. With burgeoning population and suburban encroachment into previously rural areas there is increasing competition for scarce resources. At the same time, there is increasing attention by all levels of government to assure a clean and adequate supply of water and resource protection. Within the next decade the government intends to enforce more stringent regulation to assure clean water for the future.

Horsemen were amongst the original land conservationists in this country. We have a long tradition of respect for the environment, because it is the milieu in which we operate. We must now become proactive, taking the lead in developing Conservation Plans for our horse keeping facilities to be able to answer the challenges that will be coming to us in the future as regulatory enforcement ratchets down to the local level. Not all of our new neighbors will be livestock-friendly. Most certainly, few of them will understand that the equine is unlike most other animals in many ways.

The enlightened horse keeper should begin now to take a number of actions:

- Evaluate your property for possible impacts from sediments or nutrients into water bodies and remove any manure storage away from water bodies
- Immediately write down your manure management plan, so it is ready if challenged
- Begin a Conservation Plan that includes how you intend to modify your property if your current operations are within 50 feet of riparian corridors
- Photograph your current operation and anytime you make a change
- Begin a water monitoring data program for any creeks and seasonal drainage on your property, because you will need it sooner or later.

This manual will help you to do these things yourself. It is a treasure of resources that, when implemented, could save you time and aggravation in the future since the best defense is a good offense.

*Happy Trails from Adda Quinn of EnviroHorse*

## Preface

**T**HROUGHOUT THIS COUNTRY the rural landscape is in significant transition. The face of agriculture is being transformed with the resultant loss of the family farm and subsequent proliferation of impersonal agribusiness. The vast majority of our rapidly increasing population now resides in urban and suburban areas; these non-agricultural citizens are frustrated by the immitigable impact of pollution and sprawl. Caught between these two forces are small agriculturists, including equestrians.

Equestrians are becoming aware of an increasing burden. Our small farms are being consumed by population growth, but jurisdictions fail to zone for new small agricultural parcels so we can continue our lifestyle. As dense population centers with associated noise, pollution, vandalism, and other infringements move towards our fence lines we are told we have become a nuisance. Our farms are being reclassified as “recreational facilities” because we continue the tradition of sharing use of our agricultural properties with neighbors in town. After having struggled to assist with open space preservation and trail development we are told that our impact on these areas will limit our future usage.

Most dramatically, equestrians are now being asked to develop programs to limit our environmental impact. We are threatened with regulation as our urban and suburban neighbors continue to cover their landscape with high water runoff from hard surfaces; spread fertilizers on their vast tracts of artificial landscaping; pollute our waterways with poorly regulated petrochemicals, pet excrement, pesticides, herbicides, detergents, solvents, etc.; and pollute the air with various exhausts, particulate matters, and fumes.

I’m sure fellow equestrians will recognize my words as only a partial description of the problems we face. Many equestrians are concerned that efforts such as this guide are the beginnings of regulatory infringement that will continue to result in limitation of equestrian open space usage; however, this is not the case. Our friends from the Council of Bay Area Resource Conservation Districts, in partnership with the USDA Natural Resources Conservation Service, have prepared this guide to aid equestrians with the endeavor to lead their community toward responsible stewardship of open space resources. This guide has the potential to be used as a tool to demonstrate that equestrian agricultural land usage can continue as an integral component of the working landscape through voluntary programs with minimal regulatory intervention. Use this valuable tool judiciously.

*Larry Gosselin DVM  
Alameda County Equestrian Society,  
Vision 2010 Agriculture/Open Space Committee*

## Credits

### **Lead Authors/Editors**

Lisa Woo Shanks – Project Coordinator/Resource Conservationist  
*USDA Natural Resources Conservation Service*

Martha Neuman – Senior Planner  
*Prunuske Chatham Inc.*

Alistair Bleifuss – Regional Technical Coordinator  
*Council of Bay Area Resource Conservation Districts*

### **Contributing Authors / Editors**

Amy Evans – Resource Conservationist  
*Alameda County Resource Conservation District*

Adda Quinn  
*EnviroHorse; San Mateo County Horsemen’s Association, Trails Chairman*

### **Core Workgroup**

Jennifer Allen  
*Southern Sonoma County  
Resource Conservation District*

Chris Fischer  
*San Mateo County  
Resource Conservation District*

Sheila Barry  
*Alameda County  
Resource Conservation District*

Kelly Howard  
*San Mateo County  
Resource Conservation District*

Alistair Bleifuss  
*Council of Bay Area  
Resource Conservation Districts*

Nancy Scolari  
*Marin County  
Resource Conservation District*

Laura Cossey  
*Contra Costa  
Resource Conservation District*

Lisa Woo Shanks  
*USDA Natural Resources  
Conservation Service*

Amy Evans  
*Alameda County  
Resource Conservation District*

## Acknowledgements

The Council of Bay Area Resource Conservation Districts worked with many individuals and agencies to produce this document. We thank everyone for contributing their expertise and for their commitment to promoting awareness between water quality issues and horse keeping. We extend special gratitude to those horse owners who shared their successful conservation measures and “horse sense” to help make the information accurate and understandable.

In particular, we wish to thank:

**Our Peer Reviewers:**

Joel Bartlett

*Horseman and Meteorologist*

Connie Berto

*Marin Horse Council*

Ken Brown

*California State Horsemen's Association*

Larry Gosselin DVM

*Alameda County Equestrian Society,  
Vision 2010 Agriculture/Open Space  
Committee*

Michael Murphy

*Sonoma County Horse Council*

Marcia Gibbs

*Ulatis Resource Conservation District*

**Our Technical Advisors:**

Terry Huff

*USDA Natural Resources  
Conservation Service*

Dennis Moore

*USDA Natural Resources  
Conservation Service*

**Special thanks to reviewers:**

Erik Beardsley, Rich Casale, Cliff Heitz, Lisa Hokholt, Daniel Johnson, Leonard Jolley, Beverly Kienitz, and Charlette Sanders from the Natural Resources Conservation Service; Ron Harben from Alameda Co. RCD; and Joy Zyskind from San Mateo Co. RCD.

Mike Rugg

*California Department of  
Fish and Game*

Dale Hopkins

*San Francisco Bay Regional  
Water Quality Control Board*

Dennis Salisbury

*North Coast Regional  
Water Quality Control Board*

Susan Whichard

*US Environmental Protection  
Agency*

**Illustrations and Photos:**

Sharleen Gaertner provided illustrations. Photo credits:

Jennifer Allen, Alistair Bleifuss, Laura Cossey, East Bay Regional Parks, Amy Evans, Hawkwood Hill Farms, Nancy Scolari, Lisa Woo Shanks, Paul Sheffer.

**Book Design:**

Dewey Livingston

P.O. Box 296

Inverness, CA 94937

Thanks to supporters: Maxine Durney of Southern Sonoma Co. RCD and Art Jensen of Contra Costa RCD.

## Table of Contents

Introduction .....	viii
How to Use this Guide .....	ix
<b>Chapter 1: Keeping Horses and Protecting Water Quality .....</b>	<b>1</b>
1.1—Protecting Surface Water and Ground Water Quality .....	2
1.2—Stewardship Objectives .....	6
1.3—Plan Conservation Improvements on Your Property .....	11
<b>Chapter 2: Evaluate Your Horse Keeping Facility .....</b>	<b>19</b>
2.1—Roof Runoff .....	20
2.2—High-Use Areas .....	21
2.3—Manure Management .....	24
2.4—Composting Horse Manure .....	29
2.5—Horse Wash Areas .....	31
2.6—Pasture Management .....	32
2.7—Water Resources: Creeks, Springs and Wells. Managing Septic Systems...37	
2.8—Design and Maintenance for Roads, Trails and Stream Crossings .....	40
2.9—Construction Management .....	46
<b>Chapter 3: List of Conservation Measures .....</b>	<b>47</b>
<b>Chapter 4: Conservation Measures to Improve Water Quality .....</b>	<b>51</b>
4.1—Erosion Control Measures .....	52
Seed and Mulch for Effective Revegetation .....	52
Gully Repair .....	53
Streambank Stabilization .....	55
Emergency Erosion Control Measures .....	58
Sandbags .....	59
Straw bale waterbars .....	59
Straw bale sediment barriers .....	60
Straw bale check dam .....	60
Silt fences .....	61
Sandbag pipeline drop inlet .....	61
4.2—Stormwater Management Measures: Keep “Clean” Water Clean .....	61
Roof Runoff Collection .....	61
Gutters .....	62
Downspouts .....	62
Splash pads .....	62
Diversions .....	63
Berms .....	63
Runoff Diversion .....	63
Runoff Conveyance .....	63
Grassed waterway .....	64

Lined waterways .....	65
Drop inlets .....	65
Sediment basin .....	65
Underground pipelines .....	65
Discharge Area .....	66
4.3—Measures to Manage “Polluted” Water .....	66
Filter Strip.....	66
Energy dissipaters.....	66
Riparian Buffer.....	67
Willow Sprigging .....	71
Constructed Wetland .....	72
Waste Pond.....	72
<b>Chapter 5: Resources Directory.....</b>	<b>73</b>
5.1—Technical Assistance .....	74
5.2—Seeding Recommendations for Horse Facilities in the San Francisco Bay Area .....	78
5.3—Winterization Checklist.....	82
5.4—Regulations and Permits .....	83
5.5—Threatened and Endangered Species .....	87
5.6—Photographic Monitoring .....	89
5.7—Water Quality Monitoring .....	90
5.8—Guidelines for Managing Residual Dry Matter (RDM) .....	93
5.9—Alternatives to Pesticides .....	95
5.10—Improving Songbird Habitat on Your Horse Ranch.....	98
5.11—Helpful Publications and References .....	100
Glossary.....	104
Index.....	107
<b>List of Diagrams</b>	
Sample Site Plan.....	14
High Use Areas .....	21
Pastures.....	32
Emergency Measures .....	58
Stormwater Management .....	62
<b>List of Tables</b>	
Potential Pollutants, Impacts, and Water Quality Tests .....	10
Horse Keeping Conservation Measures .....	48
Straw Bale Check Dam .....	60
Vegetation Type and Riparian Buffer Benefits .....	69

## Introduction

This guide provides practical management information to San Francisco Bay Area horse owners on what they can do to help protect the environment. Whether a horse owner has one animal or operates a boarding facility, all equestrians play an important role in assuring that our watersheds are healthy and our creeks clean. Because of increasing pressures from human activity, all potential sources of environmental pollution are under critical scrutiny. Pollution can come from either point sources (e.g., a specific manufacturing plant) or non-point sources (e.g., livestock throughout a ranch).

All human activities, including livestock keeping, can potentially affect both land and water resources. Water resources include small seasonal drainages, creeks, ponds, and both near-surface and deep ground water. As rainwater flows across the land, it can pick up and transport pollutants such as chemicals, soil and animal wastes which can be deposited into our water resources. Degradation of water resources can affect our drinking water supplies, recreational areas and wildlife habitat, as well as cause flooding, property damage, and harm San Francisco Bay and coastal estuaries. What may appear to be a small action at the top of a watershed, can, in fact, have tremendous consequences for downstream neighbors. As a result, urban and rural communities are now working together to improve water quality through integrated watershed management programs. These programs seek to include a broad base of participants from urban, construction and agricultural sectors. Horse keeping activities, as a potential non-point source of agricultural pollution, will be increasingly scrutinized to assure that horses are not contributing to environmental degradation.

The purpose of this guide is to help horse owners take a look at the big picture and to evaluate how equine facilities might affect local natural resources. It advises evaluating your horse keeping facility to look for opportunities for improvement. It suggests that developing a Conservation Plan for a horse keeping property, which describes both short- and long-term management systems, can be used to prevent and reduce environmental degradation. Finally, it seeks to heighten awareness of the need to implement conservation measures to protect streambanks and water quality for humans and wildlife, prevent accelerated movement of soil from your property, and decrease bare soil where feasible in our increasingly urban setting. Its primary focus is on erosion control, stormwater runoff control methods, and manure management.

As our neighbors move closer to horse keeping facilities it will become more important to reduce flies and dust, and maintain good relationships in increasingly congested areas.

Conservation of our natural resources is a long-term commitment. While there are short-term practices that can be implemented immediately and make a

tremendous positive difference for the environment, many conservation projects are long-term efforts requiring thoughtful planning and careful implementation. It will be important to custom-tailor site-specific management practices to your property. Some practices may work; others may not. Consult with professionals to minimize mistakes. Learn what works from other horse facilities, and share your knowledge with friends. Making informed decisions will save money, time, and energy—leaving more opportunity to enjoy your horses.

## How to Use this Guide

Whether you are planning a new facility, upgrading an existing operation, need to solve a specific problem, or want to improve your natural resources, this guide can assist you with identifying problems, and suggest proper management methods for a variety of problems horse keepers might encounter. Some conservation measures will be simple and easy to implement, while others are complex and require professional technical assistance.

This guide is presented in five chapters:

- **Keeping Horses and Protecting Water Quality (Chapter 1)** introduces water quality concerns, objectives of good management, and explains how to develop and implement a Conservation Plan.
- **Evaluate Your Horse Keeping Facility (Chapter 2)** is an overview of horse facility features and activities that are common sources of water quality concerns.
- **List of Conservation Measures (Chapter 3)** used in this manual are listed and noted throughout the guide in *bold italic*.
- **Conservation Measures to Improve Water Quality (Chapter 4)** covers specific measures to control erosion, manage stormwater runoff, and manage polluted water.
- **Resources Directory (Chapter 5)** includes a compendium of information, including how to obtain technical assistance, seeding recommendations; checklist for “winterizing” horse facilities; what facility operators should know about regulations and permits; what horse keeping managers should know about threatened and endangered species; how to measure progress using photographic monitoring techniques; how to monitor water quality using easy techniques; how to measure vegetative cover by estimating *residual dry matter* in pastures; suggestions for alternatives to pesticides; ways to improve songbird habitat; and a list of helpful publications and resources.

A glossary of terms is included in the back of the manual. Websites are included for reference. Website addresses frequently change, so search for keywords in a web browser or try the beginning words in a long website address.



## Chapter 1

# Keeping Horses and Protecting Water Quality

Healthy creeks and clean ground water reflect good land management and stewardship on the surrounding land. Good horse keeping management practices reduce potential pollution problems. It is important to be aware of the role that good horse keeping can play in the “big picture” of sustaining a healthy watershed.

**Section 1.1** describes the water resources that we seek to protect—primarily surface water and ground water.

**Section 1.2** presents three key objectives for horse keeping stewardship:

- Control erosion
- Keeping “clean” water clean
- Manage polluted water

**Section 1.3** outlines WHY a Conservation Plan should be created and HOW to make one.

## 1.1 Protecting Surface Water and Ground Water Quality

Safeguarding our surface water (seasonal drainages, creeks, rivers, ponds, etc.) and ground water is an important part of horse keeping. Aquatic life is highly susceptible to pollutants from human activities. Beneficial uses of water, such as swimming, fishing, and drinking water can also be affected. Some environmental consequences of horse keeping activities that may contribute to water pollution are:

- Sediment from eroding areas such as overgrazed pastures, roads and trails, and bare soil in *paddocks*, *turnouts*, corrals and arenas
- Polluted water draining from manure piles and *horse wash areas*
- Excessive nutrients (from horse waste) that wash off pastures during storms
- Removal of, or trampled vegetation at streamside areas that can lead to streambank erosion
- Removal of vegetation which filters and absorbs water and pollutants from runoff

### Watersheds

Understanding the connection between land, creeks, ground water and management is a key to preventing problems. A watershed is an area of land that drains into a distinct creek, river, lake, bay or ocean. It includes all major and minor creeks, seasonal drainages, riparian corridors (the vegetated area next to streams), flood plains, and land that water flows over or through on its way to a bay or the ocean. Watersheds are named after the local creeks that drain them. It is important for landowners to know what watershed their property is located in to be aware of where water goes, who they are affected by, and who they might affect.

A  
healthy  
watershed  
will  
maintain  
high  
water  
quality

A healthy watershed will have clean creeks with cool water and a thriving riparian corridor, clean and abundant ground water supplies for drinking water and other uses, and stable, well-vegetated land. A healthy watershed will maintain high water quality, provide fish and wildlife habitat, control erosion, maintain dry season creek flows, reduce flash flooding, and provide safe drinking water from wells.

Both natural conditions and human activities within a watershed influence the condition of creeks and ground water. Changes in creeks may happen suddenly as the result of a storm event (causing new streambank erosion) or a sudden change in land use (such as clearing land for development). Other problems in the watershed may accumulate and take many decades to develop—such as a creekbed becoming filled with sediment (soil particles that are transported by, suspended in, and deposited by water). Excessive sediment coming from the upper watershed often deposits in flatter reaches of channels in the lower watershed which can cause flooding and can be expensive to dredge.

## Healthy Creeks<sup>1</sup>

All creeks are important, whether they flow year-round (perennial), part of the year (intermittent), or just during storms (ephemeral). Even small seasonal drainages are important because they can carry water, soil, and pollutants into larger creeks.

In the San Francisco Bay Area, creeks should be managed so they are healthy for people and wildlife. Healthy creeks will have these characteristics:

- **Cool water** is critical for aquatic life. Cool water also helps reduce toxic levels of ammonia, which can come from decomposing horse waste and organic debris. Dense, overhanging vegetation helps keep water cool. Steelhead and salmon require water temperatures between 40° and 60° F.
- **Clean, clear water.** This means plenty of oxygen for fish and other aquatic wildlife to breathe. Suspended sediment, nutrients and salts from animal waste, fertilizers, sewage, and toxics such as metals, pesticides, oil, and grease degrade water quality and reduce the amount of oxygen available.
- **Thriving fish, amphibian, and aquatic insect populations.**
- **A variety of pools and riffles in streambeds** with abundant gravel and cobbles. Pools are depressions in the streambed with calm, deep water. Riffles are stretches of stream with moderate turbulence caused by water flowing over rocks. Pools and riffles are both important habitat areas for aquatic life. Gravel and cobbles are important for spawning and habitat for young fish.
- **A healthy riparian area** characterized by an abundance of native vegetation, minimal erosion, and some undercut banks for aquatic habitat. The riparian zone can provide food, cover, and water for deer, birds, and other wildlife.
- **A high water table.** Healthy creeks receive water percolating through soils in the water table. Acting like a sponge, the soil releases water gradually into creeks and other water bodies.
- **Clean ground water**, free of contaminants, that can be used for drinking water.



*Manage horse access to small seasonal drainageways because they carry water and pollutants into larger creeks. Moving the fence line to the left of this swale will help control erosion, keep creeks and ground water clean, and reduce muddy conditions that create problems for horses.*

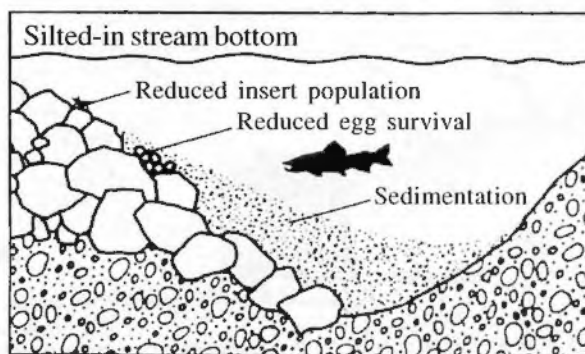

*Too much sediment is a problem for aquatic life. When sediment fills in creek beds, it also fills in pools, eliminates shelter and fish spawning habitat, and diminishes food supplies for fish and aquatic insects. Some chemical compounds can bind to sediment—potentially creating toxic conditions for fish and other aquatic life. Courtesy of Stream Care Guide, County of Santa Cruz.*

<sup>1</sup> This section is drawn from *Creek Care: A Guide for Urban Marin Residents*. Marin County Storm Water Pollution Prevention Program. 1998.

- **Water that can be used for contact and non-contact recreational activities.** Swimming, fishing and boating are popular water activities that depend on clean water.
- **Scenic beauty.** Whether in cities, suburban neighborhoods, rural areas, or parks, healthy creeks add to the scenic value of the landscape.

## An Underground Link to Clean Ground Water

Ground water and surface water are interconnected. Water not only percolates downward; near-surface ground water also flows horizontally into surface water bodies. While ground water generally follows the same path as surface water, hillside slope is not always a reliable indicator of ground water flow.

*Ground water* is an important source of drinking water. As water soaks deeper and deeper into the ground, it infiltrates and recharges aquifers, the underground layers of porous rock and gravel that store water. Ground water moves through the earth as part of a dynamic flow system from recharge areas to discharge areas such as springs and wells.

The *water table* marks the boundary in which all pore space within its soil particles are saturated with water. Water tables fluctuate throughout the year and are usually highest in early spring.

*Near-surface ground water* is the water that collects within the soil zone, usually found at four to six feet below the soil surface and is generally most vulnerable to contamination from pollutants that leach downward through soil layers. This is important because near-surface ground water often feeds directly into creeks. Near-surface ground water should not be tapped for wells.

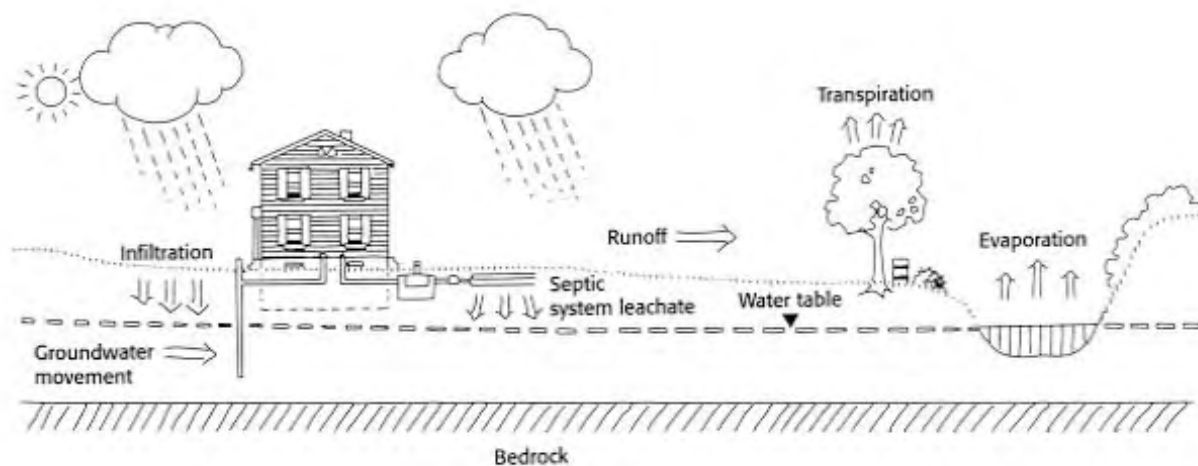

In the hydrologic cycle, water falls to the earth as rainfall and snow and returns to the atmosphere through transpiration and evaporation. Surface water, ground water, and near-surface ground water are interconnected and provide benefits to humans and wildlife. Your horse keeping activities can help or harm the natural resources on your property and those of your neighbors downstream. Source: *Home\*A\*Syst: An Environmental Risk Assessment for the Home* (NRAES-87).

## The Soil and Water Connection

Different types of soils vary significantly in their capacity to hold water, the ability to percolate water, and the types of vegetation they can support. These characteristics are important because they affect the rate at which excessive nutrients, such as nitrogen from animal waste, are carried by surface flows overland and down through the soil layers. Rainfall that can not soak into the ground starts to flow overland as runoff. Surface runoff increases the erosion hazard and the possibility for sediment and manure to be washed into nearby creeks and seasonal drainages.

The porosity, or infiltration rate, of a soil (ability of air or water to pass through minute surface openings) affects the rate at which rainfall can soak into the ground. Soil particle size influences how water moves through the ground. This may be a concern especially if the water table is relatively close to the surface. For example, sandy soils are the most porous soil and can absorb rainfall more quickly than other soil types. However, they may allow water to seep downward too quickly for effective filtration or decomposition of pollutants. Clay soils are the least permeable and absorb rainfall more slowly. However, water can still carry pollutants through the clay soils. In the summer, clay soils often shrink and form deep cracks that allow water to quickly percolate down into the soil many feet. Also, clay hardpans that underlie more porous soil will slow the downward flow of water and cause it to start moving horizontally beneath the surface, and water becomes “perched” upon the hardpan layer. Deep loamy soils support vigorous plant growth and deep roots are best for trapping and storing nutrients and other pollutants that percolate into the soil.

Soil types affect the land's ability to deal with runoff

Soil compaction occurs when livestock grazes on wet soils. Grazing by large animals can cause compaction because their hooves have a relatively small area and therefore exert a high pressure. Soil particles are pressed together, reducing the pore space between them. Compaction restricts rooting depth, which reduces the uptake of water and nutrients by plants. Compaction decreases infiltration and thus increases runoff and the hazard of soil erosion.

The type of bedrock or sediment deposits below soil layers also influences how water travels into ground water aquifers. Shale, granites, and other impermeable types of rock impede the downward movement of water and pollutants. Other rock, such as limestone, can be highly permeable, allowing water to move freely into ground water. When bedrock is fractured, water can move through it vertically, laterally or unpredictably, spreading pollutants rapidly over long distances.

## 1.2 Stewardship Objectives

Practicing good *stewardship* can help keep horse facilities, creeks, and ground water clean. Stewardship means taking care of land and water resources on your property. Neighboring landowners can also work together to promote stewardship within their larger watershed.

Three basic stewardship objectives for horse keepers to remember are:

1. Control erosion – keep soil in place
2. Keep “clean” water clean
3. Manage “polluted” water

Each of these objectives is explained below. The management systems and conservation measures presented in Chapters 2 and 4 of this guide can help landowners meet these objectives. Not only do conservation measures help control erosion, manage stormwater runoff and prevent pollutants from reaching creeks and ground water, they also create healthier conditions for your horses.

### Stewardship Objective #1: Control Erosion

Erosion occurs where soil is bare and unprotected from the forces of rainfall, flowing water, wind and gravity. While some sediment is needed to bring nutrients and substrate materials (mineral and/or organic matter that forms the streambed) to aquatic ecosystems, too much sediment causes problems and is considered a pollutant. Some soil erosion is caused by natural process. However, a great deal of erosion is “accelerated erosion” because the natural or “background” rate has been speeded up as a result of human activities. Some erosion problems may be relatively simple to solve, while others are complex.

Vegetation, geology, soil characteristics, steepness and length of slope, rainfall, and human activities (i.e., soil disturbance or alteration of natural drainages) all contribute in varying degrees to the erosion rate at a particular site. For this reason, it is important to know about the site characteristics present at each horse facility (see Section 1.2 on developing Conservation Plans).

#### Typical erosion areas at horse facilities

Humans can alter natural processes with livestock practices. Accelerated erosion can wash soil from areas of bare ground such as arenas, *paddocks*, *turnouts*, and overgrazed pastures. Severe erosion can form gullies, destabilize creek banks, and damage roads.

It is important to determine the cause of soil erosion. Accelerated erosion could be caused by uncontrolled concentrated flows from rain gutters, winter runoff from roads, removal of protective vegetation in pastures due to heavy grazing, livestock access to riparian areas when streambanks are saturated, or other ways.

### Why is sediment a pollutant?

Too much sediment reduces the ability of creeks to carry floodwaters by filling in the creek bed. Sediment fills in pools, eliminates shelter and fish spawning habitat, and diminishes food supplies for fish and aquatic insects. It can be very expensive to dredge excess sediment from creekbeds, ponds and lakes.

Accelerated erosion can also pollute drinking water supplies because herbicides, pesticides, chemicals, and organic compounds can all bind to sediment—potentially creating toxic conditions for humans and aquatic life.

### Basic Ways to Prevent Accelerated Erosion

To incorporate erosion control measures into your management systems, see Chapter 2. For specific details on conservation measures listed in *bold italic*, see Chapter 4.

- **Keep areas well vegetated** and restore bare areas with vegetation. Plant roots, especially those of grasses, hold soil in place and help water infiltrate into the ground rather than run off. Vegetation also dissipates the force of rainwater hitting the ground, which detaches soil particles.
- **Avoid concentrating water. Concentrated runoff can be highly erosive.** Try to disperse runoff by spreading it out in a thin, shallow “sheet.” Areas to watch are roads, roofs, compacted soil, and other impermeable surfaces that shed water quickly and increase the amount and velocity of runoff.
- **Control horse access and human activities in vulnerable areas** such as wetlands, creek banks, meadows and steep hillsides. Limit access, especially during wet periods.
- **Manage pastures to prevent heavy grazing.** Avoid soil compaction and excessive removal of vegetation by timing the use of pastures and controlling the numbers of horses. Rotate pastures to allow them to rest from grazing, to allow grasses to regrow and mature so they will reseed.
- **Use filter strips and riparian buffers** near creeks. Maintain a strip of *dense* grass downslope of bare areas such as *paddocks* and *turnouts* to help trap sediment. **Riparian buffers** provide valuable wildlife habitat and should contain a variety of plants including grasses, forbs, shrubs and trees.
- **Keep creek banks vegetated** to hold soil in place, trap sediment, and provide valuable wildlife habitat. Grasses have fibrous roots that hold the soil in place. A good indicator of root mass in grasses is the above ground growth generally equals the below ground root system. Shrubs and trees have deeper roots that are either fibrous or taproots that will anchor the soil in place.
- **Install kick boards** or lay railroad ties or telephone poles around arena perimeters. These will help hold footing material in place and keep it from washing away.
- **Properly construct and maintain roads, trails, and parking lots.** Protect earthen surfaces and drainage *ditches* from erosion by using properly designed drainage systems, including *diversions* and *culverts*. Use appropriate surfacing materials and techniques.
- **Use proper construction techniques.** Revegetate areas disturbed by construction. During construction install and maintain *silt fences* or *straw bale sediment barriers* to trap sediment and slow the movement of water. Avoid soil disturbing activities just before and during the rainy season.

## Stewardship Objective #2: Keep “Clean” Water Clean

Rainwater flowing across the land, or in channels or pipes, is called stormwater runoff. It is important to keep this “clean” water clean by diverting it away from areas that can be a source of “pollutants” such as a *manure storage areas*, *horse wash areas*, and other high-use areas. Keeping “clean” water clean is easier than managing and treating it once it becomes “polluted” with manure, sediment, or chemicals.

Keeping stormwater runoff away from areas with pollutants also promotes horse health. Reducing the amount of manure and mud will help eliminate insect and worm breeding grounds, reduce bacteria and fungi that cause horse disease and hoof problems, and improve footing. It will also reduce the amount of energy that horses spend trying to keep warm while standing in mud. Managing mud and manure can make tending horses more pleasant, as well as improve aesthetics for a facility, neighborhoods, and communities.



*Avoid grazing directly in creeks so horse manure and urine as well as sediment from streambank trampling does not enter waterways to create conditions detrimental to drinking water supplies, recreational activities, and the environment.*

### Basic Ways to Keep “Clean” Water Clean

To incorporate these measures into your management systems, see Chapter 2. For specific details on measures listed in *bold italic*, see Chapter 4.

- **Divert “clean” water around areas with pollutants.** Use *berms*, *grassed waterways*, *under-ground pipelines*, or other methods. Consider where water will be diverted to, and make sure you do not cause new problems.
- **Locate buildings and confinement areas away from creeks, steep slopes, and floodplains.**
- **Minimize disturbance to wetlands, riparian areas and meadows.**
- **Limit impacts of grading, runoff from roofs and other impermeable surfaces.**
- **Maintain vegetation and replant bare areas.**
- **Control potential runoff from water troughs.**

### Stewardship Objective #3: Manage “Polluted” Water

Stormwater becomes polluted if it picks up physical, chemical or biological elements as it flows through manured or bare areas. Polluted water must be managed to prevent it from reaching creeks and/or minimize leaching (moving downward into soil) into ground water. It is easier to minimize the amount of polluted water generated, rather than treat or dispose of it.

Manure and urine can add excessive nitrogen and phosphorus to creeks. These nutrients can enhance algae blooms. The algae’s subsequent death and decay can consume much of the water’s oxygen that is necessary for fish to breathe. High concentrations of ammonia from animal waste is toxic to fish and other aquatic life. Salts from horse waste can change the variety of insects that a stream can support. During the rainy season, salts and nutrients in manure can leach through soils into ground water. Pathogens in livestock waste may produce fecal coliform contamination levels that may potentially impact drinking water. Manage any polluted water generated by your facility so it does not impact downstream neighbors.

#### Basic Ways to Manage “Polluted” Water

To incorporate these measures into your management systems, see Chapter 2. For specific details on measures listed in *bold italic*, see Chapter 4.

- **Keep the size of intensively used areas small** to help reduce the volume of polluted water.
- **Manage Manure.** Remove manure regularly—daily is best. Cover stored manure with a roof, tarp or other cover, and direct runoff away from the *manure storage area*.
- **Use filter strips to trap sediment and manure** that washes off high-use and *manure storage areas*.
- **Maintain soil moisture during the dry season** by sprinkling with water to enhance bacterial decomposition of nutrients. When soil moisture is maintained in arenas, paddocks, feeding areas and even pastures, the natural breakdown of urea will occur. If areas are maintained as absolutely dry, this discourages the natural process.<sup>2</sup>
- **A waste pond** can be designed to store water for safe distribution at a later time.

<sup>2</sup> Michael Rugg, personal communication. 2001. California Department of Fish & Game, Yountville, CA.

Table 1 lists potential pollutants and related impacts from typical horse keeping activities, the associated problems they can create, and the water quality tests available to determine the levels of the pollutants. More information on *water quality monitoring* is in Section 5.7 of the Resources Directory.

**Table 1: Potential Pollutants, Impacts, and Water Quality Tests**

<b>Potential Pollutants from Horse Keeping Sources</b>	<b>Problems created in creeks, ponds, and wetlands</b>	<b>Easy water quality tests available for landowners</b>
<b>Sediment</b>	Reduces water clarity so fish have a harder time finding food; leads to warmer water, and also settles into creek beds which degrades aquatic habitat; fills in creeks and ponds; kills fish eggs from suffocation due to sediment filling in air spaces around eggs. Also, pollutants adhere to sediment particles, such as metals (e.g., lead, mercury) and organic materials such as pesticides.	Visual observation
<b>Nutrients from manure and other waste</b> <ul style="list-style-type: none"> <li>• Phosphorus from soaps and manure</li> <li>• Ammonia (decomposition of organic nitrogen such as urea and manure)</li> </ul>	<ul style="list-style-type: none"> <li>• Stimulates the growth of algae and other aquatic plants</li> <li>• Un-ionized ammonia is toxic to aquatic life even in very small concentrations</li> </ul>	Colorimetric test kit to measure total nitrate and ammonia. Test pH with electronic meter or pH test paper. Also thermometer for temperature.
<b>Salts from horse waste</b>	Affects the kinds of aquatic organisms which can live in a stream	Electrical conductivity probe
<b>Excess organic material</b> (bedding, shavings with manure, runoff from manured areas)	Acts as a source of food for aerobic, decomposing bacteria which may deplete dissolved oxygen which adversely affects aquatic life	Electrical oxygen probe or colorimeter test kit for Dissolved Oxygen (DO)
<b>Removal of streamside trees and shrubs</b>	Creates warmer stream temperatures which reduces the amount of oxygen water can carry; decreases a source of terrestrial insects (fish food); removes deep binding root mass that stabilizes streambanks; and reduces wildlife habitat	Thermometer
<b>Pesticides from fly sprays, etc.</b>	Toxic to aquatic life	Lab analysis needed – no easy tests

## 1.3 Plan Conservation Improvements on Your Property

Develop and implement a Conservation Plan to help you enhance ranch aesthetics, reduce expenses related to the control of drainage and erosion, protect property and land values, and to keep the facility safe for people and horses. Important stewardship elements of a Conservation Plan for horse facilities are to: 1) control erosion, 2) manage stormwater to keep “clean” water clean, and 3) manage “polluted” water. Planning is important whether you have just one backyard horse or a large, commercial horse boarding facility.

Conservation planning is a natural resource problem-solving process. The process integrates ecological (natural resource), economic, and production (such as pasture) considerations in meeting both the horse owner’s objectives and the public’s resource protection needs. This approach emphasizes identifying desired future conditions, improving natural resource management, minimizing conflict, and addressing problems and opportunities. This section presents information on conservation plans and outlines steps to create such a plan.

### What is a Conservation Plan?

A *conservation plan* is a document that is developed by a landowner who wishes to manage land and water resources on the property effectively. Generally help is obtained from a natural resource specialist. The planning process can help horse keepers to identify, assess, and develop ways to avoid potential water quality problems. A plan includes: a written and pictorial description of the features of the horse facility (an inventory of developed and natural features shown on an aerial photograph or scale drawing); an evaluation of problem areas and opportunities; a schedule of operation and activities needed to solve identified problems; and maintenance and monitoring activities. Plans demonstrate awareness and commitment to conservation and good land stewardship.

### Who needs a plan?

Horse properties that have creeks or seasonal drainages that lead to creeks, or that have received complaints may need a plan to demonstrate how they will manage areas of concern. If you keep horses near drinking water reservoirs or in areas with endangered species, you may be required to submit a plan to show how the environment will be protected. Owners of horse facilities may need to prepare a comprehensive conservation plan that covers more than the items discussed below in order to meet the requirements of local ordinances or a county use permit.

### How do I develop a plan?

Horse owners can gather information and develop a plan by following the five steps below. Assistance may be available from the Natural Resources Conservation Service (NRCS) and Resource Conservation Districts (RCDs). The Alameda County and Southern Sonoma County RCDs have developed a planning workbook that can be completed in conjunction with a planning course or as an

individual project. For further assistance, contact the NRCS, the local RCD, or UC Cooperative Extension, listed in Section 5.1 of the Resources Directory. Private consultants can also assist with developing detailed plans.

### **What does a plan look like?**

A conservation plan can begin simply and need not be an extensive document. A plan can be handwritten and kept in a folder or a binder. It should include maps, site-specific soils and vegetation data, a record of decisions made for conservation improvements, and other reference materials. You'll want to update your plan to keep it current. A photographic record of what is done before and after implementing a conservation plan would be helpful documentation if future questions arise.

## **Developing a Conservation Plan for Your Facility**

The degree to which a conservation plan needs to be developed will vary according to the property description and intensity of land use. A horse facility with two flat acres, no creeks and two horses kept in small shelters with paddocks may only need to create a simple plan that diverts clean water from horse keeping and *manure storage areas*, and describes manure management. However, a horse facility with many hilly acres experiencing natural gullying, or with many creeks on the property would be well-advised to develop and maintain a full ranch conservation plan. Thus, the facility manager is able to demonstrate to regulatory agencies concern for proper stewardship of the land and water resources.

The six steps for developing a conservation plan are listed below. Each of these steps is further explained in more detail.

1. Set goals for your operation
2. Inventory and map your resources
3. Identify, assess, and prioritize potential problem areas
4. Develop solutions
5. Properly schedule and install conservation measures
6. Maintain and monitor conservation measures

### **Step 1. Set goals for your operation**

Set goals for an effective conservation plan. Some issues to address are:

- **Goals for your property or horse facility.** What type of operation do you currently have and how would you like it to function in 2 years, 5 years, or 10 years? What type of facilities do you currently have, and which do you plan to add? What type of conditions do you want to provide for your horses? Because the physical health, safety, and mental well-being of your horses are essential, proper housing, sufficient exercise, food and water, and regular veterinary care should be included. Make sure the goals work for you.
- **Conservation goals for land and water.** Would you like to learn more about natural resources on your property or in your area? List conservation concerns

that you have such as reducing erosion, restoring a creek area, improving pasture productivity, or maintaining or improving a healthy ecosystem.

- **Financial feasibility.** Facility maintenance and improvement require time, labor, and money. Consider doing needed work in stages and set priorities. How much of the work can you do yourself? What help is available? Will you have a barn manager or employees for day-to-day operation? It is helpful to have contingency plans and funds for emergencies.

## Step 2. Inventory and map your resources

A written resource inventory accompanied by a map is a record of your property and improvements. Use an aerial photograph or draw a site map on graph paper to accurately and easily plot various features. Choose a scale that fits the size of your facility, e.g., 1 inch=100 feet, or 1 inch=50 feet. This map can help you determine the approximate size of structures needed, which helps in developing cost estimates. Gather existing soils, topographic maps and aerial photos for an inventory of your facility. These maps and aerial photos are available from public agencies and private sources at reasonable costs (county planning departments, NRCS, US Geological Survey, etc.). After you have completed your map, you can add areas of conservation concern and possible future conservation measures. (*See Sample Site Plan diagram.*)

Items to include on your site map:

- **Natural water features** such as springs, creeks, seasonal drainages, wetlands, and ponds. Indicate drainage and stormwater runoff patterns, using arrows to indicate the direction of flow. Topographical maps or street maps that show local creeks can help you determine drainage patterns and identify your connection to a larger stream or that enters San Francisco Bay, another regional bay, or the ocean.
- **Water improvement projects** such as developed *springs*, water *troughs*, *wells*, septic system drainfields, pipelines, and *ditches*, as well as information such as flow rates, well depth, and dates of construction.
- **Property improvements** such as buildings, corrals, paddocks, arenas, *fences*, pastures, roads and trails, *bridges*, parking areas, and *manure storage* or *composting* areas, *horse wash areas*, and other improvements.
- **Existing conservation measures** that protect soil and water resources.
- **Soil types.** Soil textures and soil depth are important for making management practice decisions. For example, steeper slopes generally have shallow soils that dry out earlier in the season. County *Soil Surveys* describe potential uses for the soil, general characteristics such as texture, erodibility, shrink/swell characteristics, water table, appropriateness for building sites and leach lines, infiltration rate, slope information, and suitability for growing plants, and contain maps (aerial photos) with the soils shown. Check with the USDA Natural Resources Conservation Service (NRCS), your local RCD, or a library to review a copy.
- Topography, terrain, and slopes can be described in your plan in general terms or with more detail if your land has been surveyed. Features to include on your

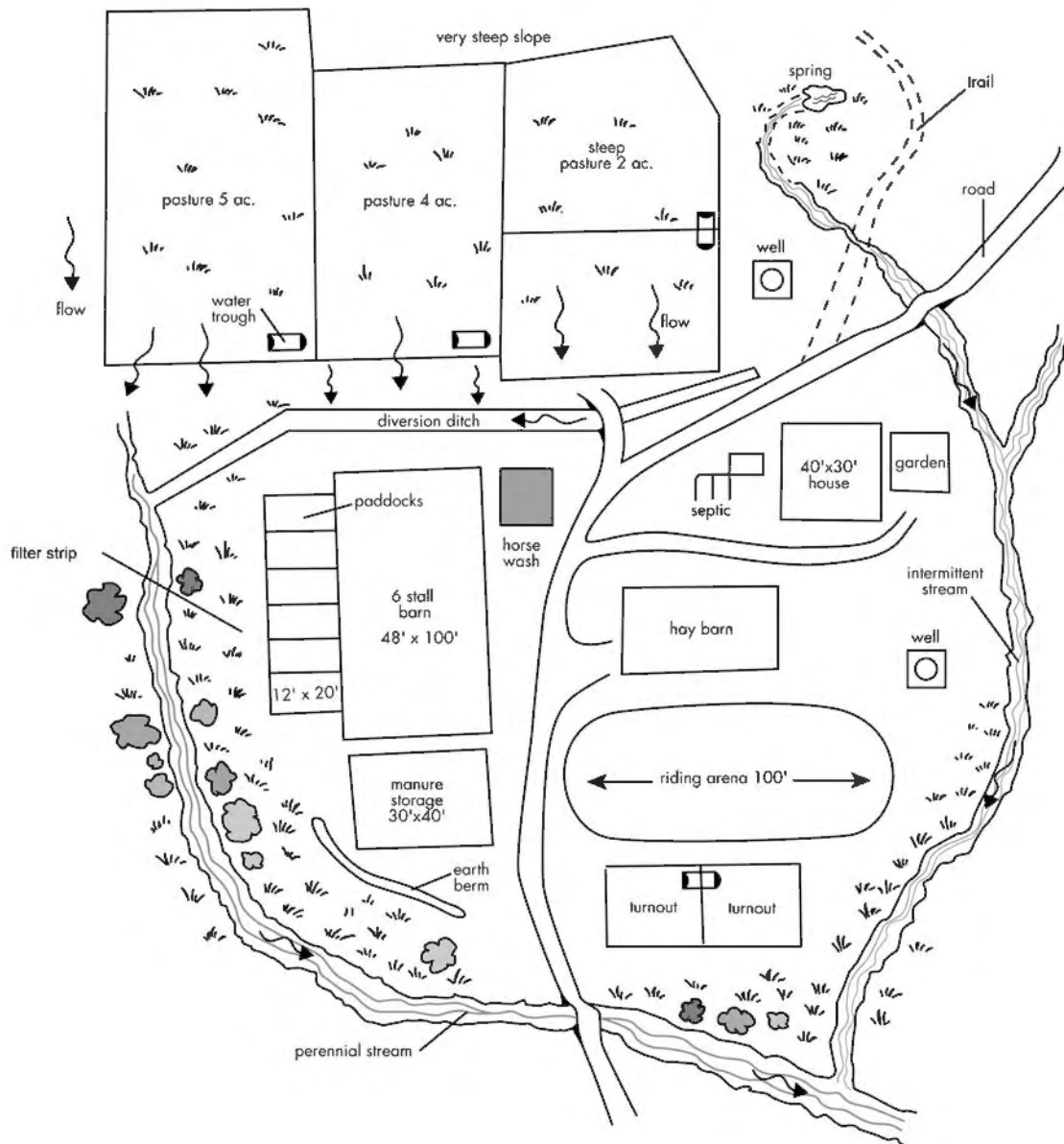

**SAMPLE SITE PLAN** – A site map shows natural features such as springs, creeks, winter swales, wetlands and ponds. Improvements are shown as well—wells, water troughs, diversion ditches, berms, septic system drainfields, pastures, fencing, turnouts, barns, arenas, and compost area. A site plan is an essential part of a conservation plan.

site map are steep slopes, low lying areas, rocky areas, landslides, and flood-prone areas. Contour lines show slope on topographic maps. Mapping tools, used with topographical maps, allow easy estimation of slopes and acreage. Topographic maps are available from local map stores, or <http://topomaps.usgs.gov/>, or <http://www.topozone.com>. Maps of landslide areas may be available for your region from the US Geological Survey, and often from NRCS or your local county planning department.

- **Vegetation and plant communities** differ in their requirements for moisture, shade, soil drainage, and soil fertility. Examples of plant communities in the San Francisco Bay Area include broadleaf evergreen woodland or forest, oak woodland, grassland, riparian (streamside forest), coastal scrub, and chaparral. If you need assistance in describing the wetland communities on your property, consult a US Fish and Wildlife Service “National Wetlands Inventory” map. These are available from the NRCS or your local RCD.
- **Wildlife habitat.** You may wish to note any important wildlife habitat areas or keep track of animal activity. Riparian habitats are especially rich in birds (both migratory and resident) and aquatic species. To find out if you have any threatened, endangered, or special status species on or near your property, contact the California Department of Fish and Game. For information on backyard conservation or wildlife habitat improvement projects, contact your local RCD.
- **Climate.** Average annual rainfall information is available from several sources such as local water districts, *Soil Surveys*, and the US Weather Service. The RCDs and NRCS have National Oceanic and Atmospheric Administration maps that show rainfall intensity. This is important for designing conservation measures (for example, how many inches per hour in a 25-year storm). A rain gauge and knowledge of local weather characteristics will allow you to monitor conservation measures during large storms. Talk to your family and neighbors to find out about any historical weather-related incidents on your property.
- **Ground water conditions** are important to know before installing wells or septic systems. Water districts, the local planning department or public health departments may have information on local ground water resources. Well records give an estimate of the depth to the water table at your property. Be sure to identify any near-surface ground water areas that may be vulnerable to contaminants.
- **Other natural resources information.** For information on geology, wetlands, air quality, or other features of interest, contact government agencies, libraries, and possibly the internet.

Look  
at your  
property  
as a whole  
to help  
develop  
priorities

### Step 3. Identify, assess, and prioritize potential problem areas

Look at your property as a whole to help you develop priorities. Refer to Chapter 2: Evaluate Your Horse Keeping Facility to help identify common sources of water quality concern. Steps to consider:

- **Evaluate your water quality to see if you have a problem.** Check areas upstream and downstream of intensively used areas. Many water quality tests are simple to perform, by conducting self-testing from kits. See Section 5.7 of the Resources Directory for water quality monitoring information.
- **Identify potential problem areas** by taking a walk around your facility, preferably during or immediately after a heavy rainfall. Use the site map as a guide and take notes.

For example, draw arrows on the site map to show runoff and drainage patterns, note bare areas such as overgrazed pastures, shade areas of streambank erosion or where sediment deposits, and note areas where pollutants may be present (such as *manure storage areas*, *horse wash areas*, or runoff from intensively used or “high-use” horse keeping areas).

- **Assess situations and prioritize areas in need of attention.** During the monitoring or field visit did you discover specific water quality issues you need to address? Are they big problems? Are they related to controlling erosion or managing stormwater runoff?

Set priorities for the areas you wish to tackle. Give high priority to problem areas that need immediate attention, and then address areas of lesser concern in stages or as part of a long-term strategy. Examples of situations needing immediate attention are where a *manure storage area* drains directly to a creek or runs off onto neighboring property, or an actively eroding streambank threatens property or structures.

- **Review your goals** and make sure the planned improvements help you achieve your goals. Revise your goals if necessary.

#### Step 4. Develop solutions

Select conservation measures that will help solve problems and achieve your goals. Chapter 4 of this guide describes conservation measures that are structural or management practices. Read through this guide, talk to other equestrians, ask questions at your local feed and stable supply stores, and seek technical assistance to determine what options will work best for you. Consult your local RCD or NRCS for assistance. Things to keep in mind include:

- **Conservation measures need to fit the unique conditions at your facility.** For example, if you have highly erosive soils, be sure that sediment is not picked up by runoff. If your streambanks are eroding, do not direct concentrated water flows into those areas. What works for others on their property may not work for you.
- **Conservation measures often work in combination.** Be aware of how they fit together, e.g., applying *seed* and *mulch* or connecting roof *gutters* and *downspouts* to a conveyance system that carries the runoff to an erosion resistant outlet at a creek.
- **Start at the source.** Seek solutions for smaller areas near the source of the problem. Sometimes minor changes in management techniques can produce the desired result at little or no cost. For example, empty *manure storage areas* before the winter, remove horses from a pasture when grass has been grazed down in order to allow for regrowth, or reseed a *filter strip* in the fall.
- **Include a manure management strategy.** Address manure collection, storage, spreading, use and/or disposal. Consider site-specific characteristics of your property and operation to determine what manure management systems will

work best. The strategy should include proximity of manure management locations to creeks, soil type, type of bedding material, number of horses, labor, equipment, and access.

- **Be aware of local, state, and federal regulations that apply to your projects.** Check carefully to be sure you have obtained all necessary permits before developing, expanding, or renovating a horse facility. You are responsible for being informed and for following regulations. See the Resources Directory, Sections 5.4 and 5.5 for more information on permits.
- **This will be a long-term process.** Some measures you may try, may not work. Your plan is a living document meant to change over time and be a record of important things you learn about the stewardship of your property.

### Step 5. Schedule and properly install conservation measures

Schedule construction during the dry season, before the winter rains. Allow time to obtain permits. Careful installation will help your projects succeed.

- **Know when to seek professional design assistance.** Medium- to large-scale erosion control and drainage projects will likely require professional design to limit the hazard of washouts, flooding, and impact to neighboring properties. Conservation measures can fail or make problems worse if they are not properly installed. Extensive grading projects are likely to require permits and professional installation.

Careful  
installation  
will  
help  
your  
projects  
succeed

### Step 6. Maintain and monitor conservation measures

Regular maintenance is crucial to the effectiveness of conservation practices. Is there room for improvement? What other conservation measures and management systems might help? Regular monitoring and maintenance will help your projects succeed. Remember to:

- **Monitor your project.** Maintenance may necessitate cleaning plant debris from gutters and pipe inlets, removing sediment from water conveyance structures, or mowing grass *filter strips* to keep the grass actively utilizing nutrients. The more useful monitoring takes place with a shovel and rain boots, walking the facility during and after a rainstorm to make sure all drainage is functioning properly. Make necessary repairs a part of your “winterization” effort. (See the Winterization Checklist in Section 5.3 of the Resources Directory.) A rain gauge will help you track rainfall amounts by storm, month, and year.
- **Be prepared,** especially after a series of storms when soils are fully saturated. This is when floods and most landslides occur. Have an emergency back-up plan and make sure that your employees and family know the plan. Have emergency repair materials on hand, such as burlap bags and sand, or straw

bales, and know the proper way to install temporary fixes. (See Section 4.1 for information on emergency repairs.)

- **Photographic monitoring** will show the results of your management decisions. (See Section 5.6 of the Resources Directory.)
- **Monitor water quality** of creeks that flow by the facility, with do-it-yourself water quality test kits, and record your efforts. (See Section 5.7 in the Resources Directory.)
- **Document your efforts** to protect natural resources. Record the implementation, maintenance, and monitoring of conservation measures. Record keeping will help you decide how to further improve conditions for your horses and water quality. Your documentation might help you meet local, state, and federal water pollution control requirements.
- **Adjust** your conservation plan based on the results of monitoring.



## Chapter 2:

# Evaluate Your Horse Keeping Facility

Keeping in mind our three key stewardship objectives, to 1) control erosion, 2) keep “clean” water clean, and 3) manage “polluted” water, we will now evaluate typical features and activities at horse facilities that are common sources of water quality concerns. For example, a *roof runoff* system includes the following conservation measures: *gutters*, *downspouts*, and *drainage* to a *filter strip* or *outlet*. The possible problem areas, as well as ways to manage water are discussed.

Horse owners can implement some management systems themselves. Professional design and installation assistance will be required for other systems. Specific conservation measures, in *bold italic*, are further defined in Chapter 4.

Typical places that can be problem areas at horse facilities are:

- **Section 2.1** Roof runoff
- **Section 2.2** High-Use Areas
- **Section 2.3** Manure Management
- **Section 2.4** Composting Horse Manure
- **Section 2.5** Horse Wash Areas
- **Section 2.6** Pasture Management
- **Section 2.7** Water Resources: Creeks, Ponds and Wells.  
Managing Septic Systems
- **Section 2.8** Design and Maintenance for Roads, Trails,  
and Stream Crossings
- **Section 2.9** Construction Management

## 2.1 Roof Runoff

Diverting roof runoff from horse keeping areas in order to minimize creation of mud will result in both healthier animals and cleaner surface water on your property.

Take a look during or after a storm to determine where the “clean” roof runoff drains from: barns, covered arenas, or other buildings. Observe whether or not water is causing erosion, creating mud, or entering areas that contain manure. For more details, see Chapter 4.2: Stormwater Management Measures, Roof Runoff Collection.

### Management Strategies for Buildings

- Locate buildings on elevated ground or built-up pads. Slope the land gently away from building foundations. Locate new buildings well away from creeks and flood-prone areas. Avoid disturbing wetlands.
- Use *gutters* and *downspouts* to direct roof runoff away from erodible land or areas with manure such as *paddocks* and *turnouts* adjacent to or attached to barns. “Clean” roof runoff should not flow through areas where it can pick up pollutants.
  - Using *gutters* and *downspouts* is especially important for large barns and covered arena roofs that can shed considerable volumes of water during storms. This “clean” water should be directed via pipe or *ditch* to an outlet point that will not erode.
- If roofs do not have *gutters*, slope roofs away from high-use and *manure storage areas*.
- Install *subsurface drains* (perforated pipe) with gravel filled trenches below eaves to collect standing water and direct it away from buildings.
- Divert water from surrounding slopes away from buildings. Install *diversions* or *berms* to direct water away from buildings. Convey water to a *filter strip* or *grassed waterway*. Make sure the *diversion* or conveyance method does not cause erosion.
- Place *energy dissipaters*, such as rock, at pipe outlets to prevent erosion.
- Revegetate areas that have been graded or disturbed to prevent erosion. Maintain *grassed waterways* and *ditches*.
- Follow county regulations regarding creek or other setbacks, such as property line, well, or septic leach field setbacks, and obtain necessary grading permits.

## 2.2 High-Use Areas

In this guide, the term “high-use areas” refers to specific fenced areas of bare ground where horses are kept, confined, exercised, trained, or ridden. Examples of “high-use areas” are *paddocks* attached to stalls, *turnouts*, circle pens, arenas, and livestock alleyways between paddocks and barnyards.

Because these high-use areas often lack vegetation, they can be subject to erosion. They are also likely to contain manure and urine that must be prevented from being carried by runoff into creeks. It is important to prevent leachate from accumulated manure from being carried into the creeks as runoff, or downward through soil into the ground water.

Mud and accumulation of manure in high-use areas can also pose health problems for horses, and make access difficult for people.

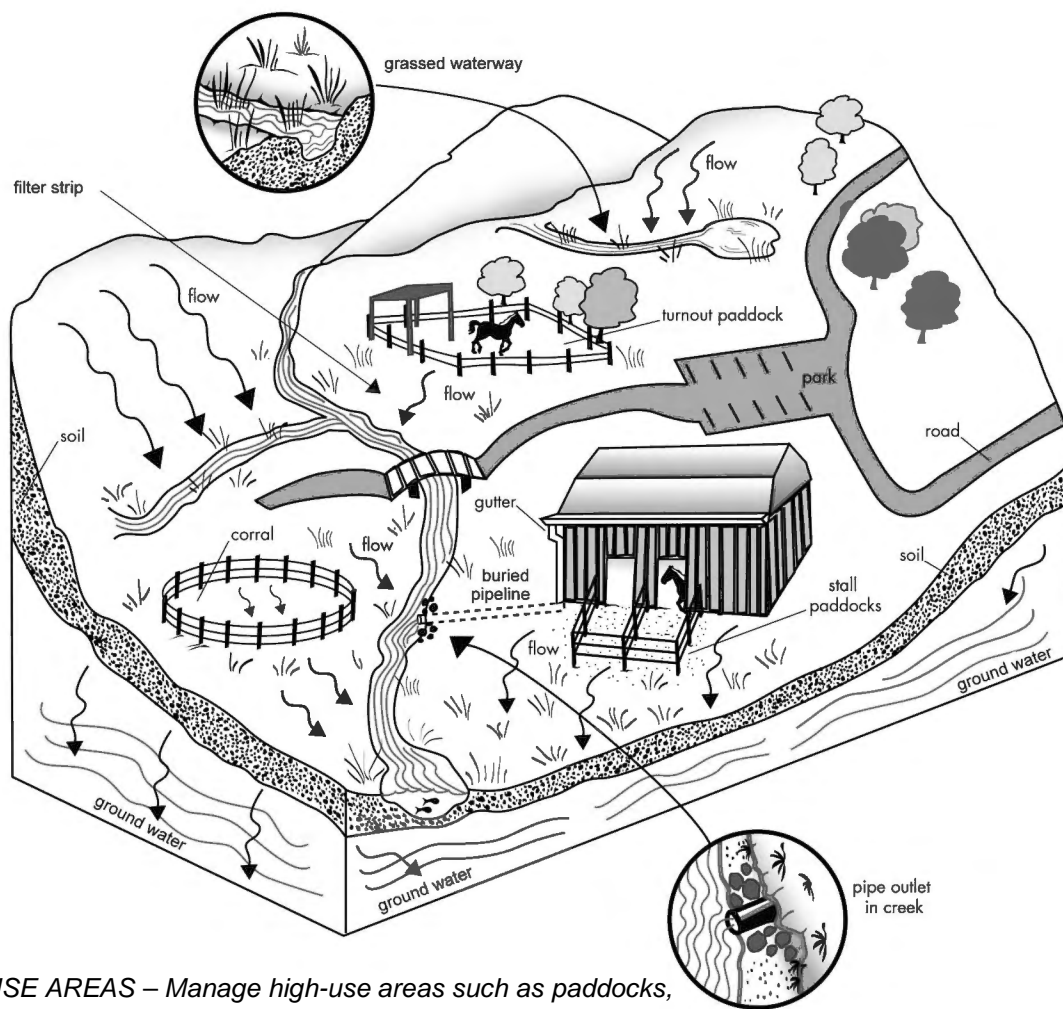

**HIGH USE AREAS** – Manage high-use areas such as paddocks, corrals, turnouts and arenas to keep manure and urine from reaching creeks, prevent leachate from being carried downward into the soil and ground water, and reduce erosion. Map the flow of drainage at your facility and look for ways to keep “clean water” clean. Consider using conservation measures such as **turnout paddocks** and **grass filter strips**.

## Management Strategies for High-Use Areas

### Consider location and size

- Locate high-use areas on higher ground with a slight slope for drainage (1-2%). Locate high-use areas away from low spots, drainages, floodplains, or areas that receive a lot of upslope runoff. If there are chronic drainage problems, facilities may need to be relocated.
- Limit the size of high-use areas to what is truly needed. The smaller the area, the less “polluted” runoff will need to be addressed.
- Locate high-use areas in flatter portions of the property. Avoid steep slopes (generally over 30% slope) that are susceptible to erosion.
- Use *fencing* to reconfigure the shape of the high-use area to suit the terrain. Follow county regulations that may require setbacks from creeks, wells, septic leach fields and property lines.
- Consider wind direction for dust control.



Maintain grass **filter strips** adjacent to high-use areas such as arenas to help trap and filter sediment and manure that flow off of these areas.



A grass **filter strip** will help trap sediment that may run off a horse paddock. Be sure to develop good drainage in high-use areas such as horse paddocks. Create built-up pads, use proper footing materials, and divert clean stormwater around paddocks to help reduce mud.

### Maintain vegetation around high-use areas

- Develop and maintain a *filter strip* of dense grass between drainages (even small, seasonal ones) and high-use areas to trap and filter sediment from runoff. See Section 4.3 for more information on *filter strips*.
- Reseed grass, if necessary. *Seeding* recommendations are in Section 5.2 of the Resources Directory.

### Improve drainage in and around high-use areas

- Use base rock and sand to improve drainage in high-use areas and to improve the surface or footing. For horses’ health, high-use areas should have well-drained surfaces. “Road base” which consists of a mixture of clay, sand and crushed rock (or gravel) may be needed as a foundation for horse comfort in stalls and small *paddocks*. Too fine a surface may not allow water to infiltrate and can cause ponding.
- Create built-up pads by “crowning” (building up the center) the pads to promote runoff rather than ponding and infiltration.
- Place filter fabric underneath the drain rock in stalls and small *paddocks* to prevent the rock from mixing in with the soil and subsiding. It costs a bit more money up front, but works better in the long run. The alternative is to keep adding rock, which adds stability to the site, however, it could be an ongoing expense.

- Prevent “footing” material from washing off site. Footing that washes off high-use areas could become a form of sediment that should not be allowed to enter creeks and seasonal drainages. Kickboards, made of railroad ties, telephone poles, or boards placed around the perimeter help prevent footing from washing away.
- Use a *diversion* to route “clean” stormwater runoff around the high-use area.
- Locate shelters along the edges of *paddocks* rather than in the middle so roof drainage can be more easily controlled.

### **Manage manure regularly**

- Regular clean up of manure, soiled bedding, and uneaten feed will minimize the amount of pollutants in high-use areas. Uncollected manure adds to mud problems because it absorbs water. Scrape or otherwise remove manure before winter. Evaluate the manure management element of your *conservation plan*.

### **Keep paddocks, corrals, and arenas as dry as possible during the winter rainy season**

- Plan horse traffic patterns to avoid wet areas and minimize the formation of areas without vegetation. Select drier areas for the location of gates and other high traffic uses.
- Consider using deep bedding to prevent horses from standing in mud. These bedding materials are usually wood products, up to a foot in depth and can be used in outdoor situations. Various commercial products are available. A filter fabric may be required beneath the deep bedding to keep it from being trampled into the soil. Kickboards placed around the perimeter help retain the bedding on-site. Be aware that wood shavings, once saturated, can produce sufficient amounts of tannolignic materials to create a toxic leachate, which can pollute runoff.
- Use rubber mats over “road base” with bedding materials to keep stalls and other high-use areas dry in the winter.
- “Scratches,” also known as “grease heel,” “grease,” “cracked heels,” or “mud fever,” is a dermatitis (inflammation of the skin) of the heel and rear side of the pastern area. It can develop or be aggravated when horses stand in muddy corrals for long periods without relief.<sup>3</sup>
- Use clean fill such as soil for low spots. Don’t use manure. As an organic material, manure holds water and actually adds to mud problems.

---

<sup>3</sup> James, Ruth B., DVM. 1990. *How To Be Your Own Veterinarian (Sometimes): A Do-It-Yourself Guide For The Horseman*. North Carolina: Alpine Press.

- Consider using ground oyster shell or various commercial products to dry urine-soaked or wet areas.
- Plant grasses, shrubs, and trees around high-use areas to utilize excess water, and to help keep the area drier.
- Native trees and shrubs such as California bay laurel, toyon and coffeeberry

### Weed References

For noxious weed information, visit the California Department of Food and Agriculture ENCYCLOWEEDIA:  
[http://www.cdffa.ca.gov/phpps/ipc/encycLOWEEDIA/encycLOWEEDIA\\_hp.htm](http://www.cdffa.ca.gov/phpps/ipc/encycLOWEEDIA/encycLOWEEDIA_hp.htm)

To learn more about noxious weed eradication in your county, visit the CALWEED Database, California Noxious Weed Control Projects Inventory:  
<http://endeavor.des.ucdavis.edu/weeds/>

continue to use water during the winter when deciduous trees are dormant. (Do not plant anything that is toxic to horses. If oleander, oaks, walnut trees, etc., are consumed, they will make horses sick). Trees work well on the north side of a high-use area where they will not block the sun's rays. Protect trees from damage by horses by using heavy fencing, or horses will push down the fence to eat the leaves and bark. Trees in paddocks may have problems because horses also like to scratch on tree trunks and long limbs. Compaction of soil within the trees' drip line can harm roots.

### Practice dust control measures

- Keep areas as vegetated as possible.
- Plant native trees for windbreaks and dust screens. Keep horses away from plantings by installing conventional horse *fencing* or an electric fence.
- Sprinkle water on arenas and *paddocks* to keep down dust during the summer. This also helps degrade urine salts that could otherwise accumulate in arid western soils during the long dry summer.<sup>4</sup>

## 2.3 Manure Management

Proper manure management will help maintain a healthy environment for horses, provide a clean and safe working area for people, and protect water quality in creeks and ground water. Effective manure management can reduce waste volume, removal costs, fly breeding, and neighbor complaints.

### Management Strategies for Manure Storage Areas

#### Develop and implement a manure management element for your *Conservation Plan*

- Be sure to include a description of the facility's plans for manure collection, storage, and use or disposal.
- Consider characteristics of your property and operation to determine what manure management strategies will work best. Take into account: proximity of manured areas and manure handling areas to creeks, runoff from surrounding slopes, soil type, presence of near-surface ground water, type of bedding

<sup>4</sup> Michael Rugg, personal communication. 2001. California Department of Fish & Game, Yountville, CA.

material, volume of material (manure and bedding), number of horses, availability of labor and equipment, and access for clean-out and storage areas.

- Develop storage options. Storage facilities could include covered bins, sheds, concrete pads with low walls, windrows, piles covered with plastic tarps, dumpsters, trucks, or covered garbage cans. One 1000-pound horse may produce 0.75 cubic feet per day of solid waste plus urine.<sup>5</sup> Remember to add the volume of bedding when sizing a storage facility.
- Develop options for manure utilization such as **composting**, disposal, and land application. Determine the pasture or crops available to utilize nutrients in the manure or compost produced.
- Talk to your neighbors and local RCD. Your solution should be appropriate to your area. It may be possible to develop solutions for a neighborhood or even a region.

### Clean up manure

- Clean up manure, soiled bedding, and uneaten feed from stalls and **paddocks** regularly. Daily removal is best, especially during the rainy season.
- Use proper tools and a convenient storage site to simplify clean up. Find a manure fork that works. Some carts are too big, while others are hard to push around or awkward to dump.
- Scrape or otherwise remove manure from high-use areas, such as corrals and arenas.
- Pick up or spread manure periodically if horses deposit it in one area.

### Store manure and compost properly

- Store manure and compost away from creeks and wells.
- Make sure that the **manure storage, compost area**, or disposal container is appropriately located and sized for loading and unloading and can handle the appropriate quantity of manure cleanouts. Loading ramps are useful if manure can be loaded directly into a dump truck or dumpster. If tractors will be used, be sure the facility is large enough and strong enough for the equipment.
- Locate the storage or **composting area** on a water-tight surface such as compacted clay,



*Proper manure management is essential for horse owners. Manure cleanup, storage, and use are critical components of conservation planning and good stewardship.*



*Composting manure may be an excellent way to handle large quantities of manure and create a useful product. Be sure to calculate the waste volume and allow for equipment access. Proper stormwater management and drainage should be installed near composting areas.*

<sup>5</sup> Livestock Waste Facilities Handbook. 1985. Midwest Plan Service – 18. Iowa State University, Ames, Iowa.

concrete, or plastic to reduce the potential for seepage of leachate (liquids high in salts and nutrients draining from manure piles) into ground water.

- Check regulations and required permits before grading for manure storage pads, especially when working around environmentally sensitive areas such as wetlands or streams.
- Install proper stormwater management and drainage measures (see Section 4.2) to route stormwater away from the area. Divert any runoff that leaves the *manure storage* or *composting area* to a *filter strip*. Vegetation will utilize the nutrients in manure and help filter manure particles that are carried along in runoff.
- Use a *cover*, such as a tarp, to protect stockpiled manure from winter rains. Shape piles in long rows, so that the width fits the size of the plastic sheeting used to cover the manure. Tie or weigh down edges and corners as necessary.
- Empty storage areas before the winter rains to reduce the volume of manure that must be contained.
- Take odor into account by considering prevailing winds, and distance to your neighbors.

### **Develop and implement a nutrient management element in your *Conservation Plan***

- Take into account your pasture's needs and determine the amount, placement, and timing of *manure application or spreading* to maximize plant growth and minimize the potential for polluting creeks and ground water.
- Have your soil analyzed by a laboratory *before spreading manure* to determine fertilizer needs, and establish a baseline for future monitoring. This is especially important if manure has been applied to the field for many years. Nutrients such as nitrogen and phosphorous are released over time (many years), so a field that has been used for manure disposal may already be quite high in nutrients and salts.
- Consider having a laboratory analysis of your horse manure to determine the total analysis. This will help ensure that *manure application* meets, but does not exceed plant nutrient requirements. For example, some of the nitrogen in manure may not be immediately available for plant use or additional fertilizer may be needed for specific nutrients.

### **Visual Inspections of Manure Storage Areas**

Examine the condition of, and make any repairs to:

- Concrete – Cracks or openings, signs of infiltration, crumbling or rust
- Wood – Splitting, buckling or rotting
- Earthen containment walls – Settling, seepage, slumps, or animal burrows
- Wall alignment (vertical and horizontal) – Curves or bulges
- Foundation – Erosion or piping
- Liners – Tears

*Stockpile manure on an impermeable surface. Size the manure storage area according to the amount of manure and bedding produced. The base must be a water tight surface to reduce the potential for seepage of leachate into ground water. The surface must be designed so it can be scraped with a shovel for small facilities, or a front-end loader for larger facilities. Cover the manure storage area so there is no liquid draining from the stack. A tarp or roof must drain away from the manure stack. Roof height should be a minimum of 7 feet, and also be designed to accommodate heavy equipment. Liquid from the manure may accumulate in the storage area and should be absorbed and removed with the bedding material. Empty the storage area before winter to reduce the amount of material to be stored.*

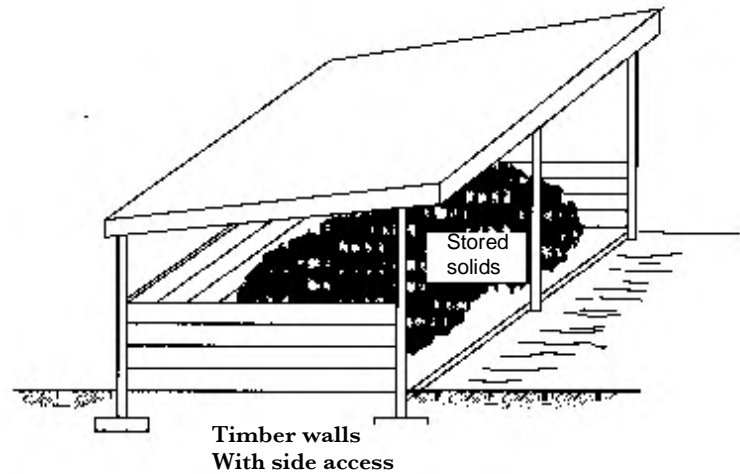

### **Use compost and manure properly as a fertilizer and soil conditioner**

- Properly calibrate your manure spreader to avoid over-application. Applying more manure than plants will utilize wastes nutrients. Excessive nitrogen and phosphorus in soils can be lost to ground water by leaching or to surface water through runoff.
- Apply manure and compost to actively growing pasture in the spring so nutrients will be utilized. Wait until after the winter rains when the ground is firm. Additional application in the fall before the winter rains will free up space in the **manure storage area** for the winter.
- Do not spread manure near creeks or on steep slopes where it can be carried to creeks by stormwater runoff.
- **Compost** bedding materials with manure before application. If undecomposed bedding is applied with the manure, soil organisms will use the available nitrogen to decompose the bedding—reducing the nitrogen accessible for plant growth.
- Use caution when spreading horse manure that has not been composted. Manure may contain weed seeds brought in with hay. Buy hay certified by the Agricultural Commissioner as “weed free,” or compost horse



*Never store manure near creeks. Rainwater running through this manure pile would run directly into the creek below to the left. Excessive nitrogen from manure feeds algae blooms that ultimately consume much of the oxygen in water. Ammonia from urine and manure can be toxic to aquatic life.*



*Local nurseries, landscapers, gardeners, agricultural operations, or community gardens may want manure. A hauler may be able to regularly pick up manure from neighboring horse owners. Manure should be composted before using in gardens.*

manure to kill weed seeds. Also, spreading manure onto pastures may risk the spreading of internal parasites, if not composted.

- Incorporate manure or compost immediately into the soil by shallow disking or harrowing to increase nutrient availability for plants.
- Spread compost under the canopy cover (drip line) of trees, and be careful not to bury the root crown.
- Keep records of manure and soil tests.
- Keep records of manure and fertilizer applications, and the results of forage production.
- Give away or sell good quality composted manure.

### **Dispose of manure properly**

Do not store manure near creeks or in places where runoff from manure piles can affect creeks or ground water.

- **Compost** manure into topsoil and use this valuable by-product to enhance your own property; give it away to local farmers with pasture, orchards, vineyards or annual crops; landscapers; community gardens; or sell it.
- Haul manure away for disposal. While this is usually a costly alternative, it may be the only one available for certain properties. If so, work with neighbors to encourage a local *manure hauling* system.
- Exchange, recycle or swap manure with others. The California Materials Exchange (CalMAX) links those looking for organic material or compost with stables providing horse manure. For more information, visit the website at <http://www.ciwmb.ca.gov/calmax>. Local programs such as the Sonoma Materials Exchange (SonoMax) is a free service helping local business find reuse and recycling opportunities. The goal is to reduce the amount of waste in landfills while giving business an opportunity to save on disposal costs. For a listing, contact: <http://www.recyclenow.org/sonomax>

## 2.4 Composting Horse Manure

Caring for your horses can require a considerable amount of time, energy and expense managing manure and soiled bedding. **Composting** manure decreases the volume of waste. It is easier to handle composed manure, and turns the waste into a usable product.

### Composting Horse Manure: Turn Straw into Gold

For some horse facilities, **composting** horse waste may be an effective method to handle manure and stall waste generated by horses. **Composting** manure requires controlling conditions to speed up the natural process of decomposition. The benefits of **composting** include efficient manure management, reduction in manure volume by more than 50%, lower risk of surface and ground water contamination, and fewer odors. Compost heat kills worm larvae and reduces the parasite transmission between horses, as well as eliminates breeding ground for flies. Compost is a great soil conditioner—organic matter improves soil structure, drainage, and water retention. It also provides nutrients for plants, and the heat kills weed seeds and pathogens.

### Compost basics<sup>6</sup>

Horse waste can be composted in numerous ways, although all methods require the same basic ingredients and conditions. Compost is created from a blend of nitrogen rich materials such as manure, carbon rich materials such as bedding, air, and water. Horse manure alone has close to the desired carbon to nitrogen ratio of 30:1. The compost material should be as wet as a wrung out sponge and well aerated to provide a favorable environment for the microbes that decompose horse waste.

**Composting** requires one to three months depending on your method and management.

Different methods of **composting** include using bins and turning the compost by hand (for aeration) or long windrows that are either turned with equipment or passively aerated with perforated pipes running through them, that require mechanical blowers and pipes to force air through windrows or piles. It is



*Manure is breaking down into **compost**, laid out in windrows for easy turning by tractor. Compost is curing at a different stage in each windrow, and new manure is constantly added to new windrows. Nitrogen-rich materials (such as manure), carbon rich materials (such as bedding), air, and water are used to create compost. Proper moisture and aeration are important. Turning horse manure into compost takes one to three months.*



*Make **compost** in bins or long windrows that are turned with equipment or aerated with perforated pipe. Piles should be less than 6-8 feet high.*

<sup>6</sup> Information drawn from: *On-farm Composting Handbook* (NRAES-54), Northeast Regional Agricultural Engineering Service Cooperative Extension, 1992. New York.

important to maintain proper height (lower than 6-8 feet) and moisture levels, especially during hot and dry conditions. Piles more than 12 feet high with less than 25-45 percent moisture content could spontaneously catch on fire.

## Planning your composting project

The number of horses, labor and equipment available, space available, and management cost and time will determine whether *composting* will work for you and the method to use. To learn about *composting* options, talk with local certified Master Composters and Master Gardeners (who provide public assistance through the University of California Cooperative Extension) and visit horse facilities that compost. Also see the *Composting Horse Waste* Fact Sheet published by the Council of Bay Area Resource Conservation District's Equine Facilities Assistance Program. Contact your local RCD for a copy. (See Section 5.1 of the Resources Directory for contact information.) Private consultants may be needed to help you develop a large-scale system.

Factors to consider in planning your project:

- **Size.** Plan adequate room to handle the anticipated volume of horse waste plus equipment access. If you have a large operation, check with your local planning department before establishing a *composting* operation. Generally, horse waste can be composted and used on-site without a permit from the state although there may be notification, filing and record keeping requirements. Counties and local governments will probably require review of an operation plan.
- **Zoning regulations.** These may require setbacks from creeks or property boundaries. The regulatory aspects of *composting* are covered in Title 14, Division 7, Chapters 3.1 and 5.0 of the California Code of Regulations. County permitting departments may have requirements that need to be met.
- **Slope and drainage.** To prevent stormwater runoff from entering *compost areas*, windrows and bins should be on flat ground or oriented up and down a very gentle slope (not across the slope where more water can drain into the pile). The surface area should be compacted or paved to prevent seepage, particularly in an area with sandy or gravelly soils or with a high water table. Any compost runoff should be directed to a *waste pond* or *filter strip*.
- **Water supply.** A nearby source of water is often needed because *composting* may require additional water to maintain moisture content.
- **Wind.** Wind direction is important to consider for dust control and odors. For example, downwind neighbors may be affected when piles are turned.
- **Conservation Measures.** Be sure to include the same conservation measures as you would for *manure storage areas* (see Section 2.3, Manure Management).
- **Combustibility.** Under certain conditions, immature compost can undergo self-heating and spontaneous combustion from the heat generated by microbial decomposition. Confined storage, which traps heat, may exacerbate these conditions. Management plans should be developed to prevent this occurrence and contingency plans should be in place to respond appropriately if self-heating occurs.

## 2.5 Horse Wash Areas

Runoff from horse wash areas may contain soap and limited quantities of manure, chemicals and pesticides from horse health and grooming products that should not be allowed to reach nearby creeks or percolate into ground water.

### Management Strategies for Horse Wash Areas

- Prevent wash water from percolating into permeable soils if there is near-surface ground water or a high water table. A storage *tank* for wash water may be necessary.
- Elevate the wash area with a built-up layer of crushed rock if the wash area is fairly flat. Wash water should drain away from the area to a *filter strip* or other vegetated area.
- Do not allow water from horse wash areas to flow into creeks, ponds or seasonal drainages.
- Keep the wash area free of manure and horse care products.
- Prevent wash water from flowing into storm drains (storm drains typically drain into creeks).
- Create a *filter strip* downslope of the wash area, or move the wash area to an area where a *filter strip* can be developed. Make sure the *filter strip* can accept the amount of wash water generated. Use *berms*, or other conveyance measures, if necessary to contain and direct water to the *filter strip*.
- Consider using *constructed wetlands*, *grassed waterways* or *waste ponds* as treatment areas for horse wash water.

### Use horse grooming and health care products properly

- Use a shut-off nozzle or low-flow nozzle at the end of the hose.
- Consider sponging off your horse to conserve water.
- Use plain water to rinse horses—avoid using soap as much as possible.
- Follow instructions, read environmental warnings, use only the recommended amounts, and clean up spills. Even biodegradable horse grooming and health care products can have a negative effect on water quality.



*A curb directs horse wash water away from the creek. Keep horse wash water out of creeks, seasonal drainages, and storm drains. Horse wash areas should be kept clean of manure and grooming products.*



*This horse wash area drains into a grass filter strip (along the row of trees). The filter strip traps sediment, horse manure and other contaminants.*

- Use products that do not contain surfactants if wash water might eventually enter creeks. Surfactants, a group of chemicals that make detergents more effective cleaners, are extremely toxic to all aquatic life and can even impair the ability of young salmonids (steelhead and coho salmon) to adapt to ocean waters after they leave freshwater streams.

## 2.6 Pasture Management

When managing pastures, consider yourself in the business of growing grass. Grass will provide more forage for your horses and protect the soil from erosion. In healthy pastures, grass roots increase the soil's absorption of rainfall, storing moisture to prolong the growing season. In turn, a longer growing season produces more grass. Grass stems slow the rate of overland stormwater runoff. Slowing the rate and reducing the amount of runoff from hillside pastures may reduce drainage problems elsewhere on your property. A grass cover with little bare soil is ideal.

Horses can damage pastures quickly without *grazing management*. Renovation of pastures is costly. Take care of what you have by controlled *grazing* and “resting” pasture so it has time to regrow.

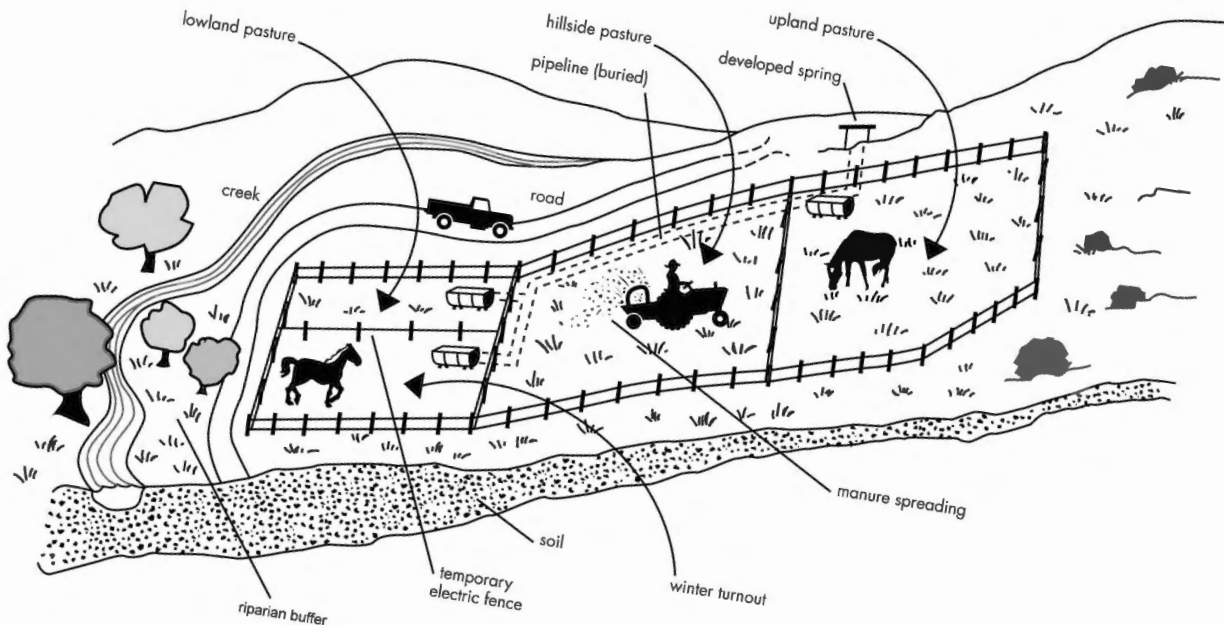

*PASTURES* – Proper pasture management can include using **cross-fencing** to promote uniform pasture use, controlling the number of horses and **grazing distribution** within pastures, controlling horse access to creeks, developing a **spring** as a new water source, and restricting pasture access during the wet season.

## Management Strategies for Pastures<sup>7</sup>

Control horse access to creeks and other water sources

- Control horse access to creeks to prevent manure and urine from being directly deposited in or near creek channels.  
*Fencing* to keep horses out of creeks may be necessary.
- Control horses *grazing* along creek banks to reduce trampling and erosion of banks that leads to sedimentation of waterways.
- *Graze* riparian areas seasonally when soils are dry enough to withstand the weight of the horses, to keep streambanks from being trampled and broken down.
- Provide horses with alternative sources of water if creek *fencing* is installed. Small pasture shelters may be necessary to provide a new source of shade and shelter.
- For crossings or water source, narrow horse access to a point at a creek where the channel can be armored or protected with gravel or other means.

### Improve animal distribution to help reduce bare areas and control undesirable weeds.

- Manage the number of horses and control *grazing distribution* to prevent heavy grazing.
- Develop and adjust a rotation *grazing* schedule to provide pastures with periods of *grazing* interspersed with periods of rest.
- Locate feed, salt, minerals, and water away from creeks. Regularly move the salt blocks to distribute *grazing*. Place hay piles far apart with more piles than the number of horses being fed. This will minimize trampling from fighting horses and maximize distribution.
- Use *cross-fencing* (dividing up a pasture with fencing into smaller cells) to improve



*Overgrazing occurs when plants are so heavily grazed that the root system dies back and plants eventually become less productive or die. A balance of grazing and pasture rest will prevent overgrazing, improve forage production, and keep weeds down.*



*Be sure to control horse access to vulnerable erosion areas such as a rill in a pasture. Repairing a problem early and installing temporary **fencing** can help prevent the need for a more costly fix later (such as when a rill turns in to a gully).*



*Overgrazed pastures lack plant cover and are susceptible to erosion. Keep horses out of highly erodible areas and **seed** bare areas. Gully repair is likely to require professional assistance.*

<sup>7</sup> USDA, NRCS - California, Field Office Technical Guide, Prescribed Grazing, July 2000.



Adequate “**Residual Dry Matter**” (*RDM*) leaves enough plant residue on the soil surface to protect against soil erosion, and leaves a sufficient seed source for annual pasture regeneration. *RDM* is measured in the fall, just before the winter rains. The minimum levels of *RDM* that should remain in a pasture is 800 – 1000 lb/ac in the San Francisco Bay area. This pasture has 900 lb/ac of *RDM*. Pasture production varies from year to year, with rainfall being a primary influence. Therefore grazing must be monitored and grazing levels adjusted, each year

**Residual Dry Matter** (*RDM*) is used as a tool to determine adequate erosion control on pastures. *RDM* is measured by clipping the grass in a ring, and measuring the weight of the dried grass. This site has 900 lb/ac of *RDM*. For visual estimates of *RDM*, refer to the “*Residual Dry Matter Monitoring Photo-Guide*” produced by Wildland Solutions.



evenness of pasture use. **Cross-fence** pastures according to the terrain, soil wetness, and land sensitivity (e.g., steep slopes will erode more easily). Lowland pastures will probably stay green later into the summer and may be too wet to be grazed without damage in the winter. You may need to add alternative water sources for horses.

Portable electric fencing is easily installed and affordable, and can be used to define **grazing** areas if the horses are allowed to acclimate to the new fencing (temporary flagging helps to demarcate the fencing).

- Provide alternative sources of water by developing **springs** or extending an existing water system.
- Small pastures should be used for exercise rather than forage production.
- Maintain sufficient **residual dry matter (RDM)** for pasture reseeding and erosion control. *RDM* is the amount of dry grass stems left behind after the grazing season has ended. Be prepared to move horses to another pasture or a **paddock** once target *RDM* levels are reached or exceeded. The rule of thumb is to leave 4 inches of grass stems in the pasture. See Section 5.8 of the Resources Directory for more information on *RDM*.

### Properly manage pasture use

- Turn horses out for only a limited period of **grazing** each day to increase the duration of a pasture’s use and to reduce soil compaction. **Grazing** when the soil is wet causes soil compaction. The soil particles are pressed together by

concentrated pressure from livestock hooves, reducing the pore space between soil particles. A dry soil is more resistant to compaction than a moist or wet soil. Compaction restricts rooting depth, which reduces the uptake of water and nutrients by plants. This affects the activity of soil organisms by decreasing the rate of decomposition of soil organic matter and subsequent release of nutrients. Compaction decreases infiltration and thus increases runoff and the hazard of water erosion.

- Feed horses before turning them out to reduce the *grazing* pressure on grasses.
- Remove or spread manure if it has accumulated in a particular area. This will promote plant growth and reduce parasite populations. Horses should not be forced to eat the forage where manure is deposited.
- Restrict use of wet pastures. Some pastures may be too wet to use during the rainy winter months. Confine horses to *paddocks* during this time and use pastures seasonally during the dry months.



*Control winter access to soggy pastures to help prevent pollutants from leaching into the ground water and to keep horses out of the mud. Fence out springs and seeps.*

### Develop and use turnout paddocks

- Develop *turnout paddocks* in flatter portions of pastures, away from creeks. Turnout areas include exercise lots, pens, corrals, and small *paddocks*. Follow the guidelines for high-use areas (See Section 2.2).

*Paddock* size depends on the number of horses and other considerations. Keep *paddocks* to a minimal size to limit the amount of bare ground. General guidelines are a minimum size of 600-800 square feet per horse, with a slope of less than 5% and good drainage. Keep the paddock surface as dry as possible during the rainy season to reduce the possibility of polluted water from running off the area, and also be healthier for horses.

- Preserve pastures by keeping horses in *turnout areas* when grass has been grazed down (less than 4-6 inches high).



*Turnout paddocks (exercise lots, pens, corrals, and small paddocks) can be used to keep horses off wet pastures. This will help protect pasture soils and grass cover.*

### Follow seasonal pasture management strategies

- Keep horses in *turnout paddocks* and off pastures when soils are wet.
- Give exuberant horses time in a *turnout area* during the rainy season before putting them on pasture. This will help horses release their energy and protect turf from being churned.
- Keep horses off steeper slopes when pastures are wet.
- *Seed* and *mulch* bare areas.

- Remove weeds as necessary and make sure that removal occurs at the proper time of year (this will vary by weed species).
- Monitor grass height and weed growth at the end of the growing season (late spring/early summer).

### Watch gully formation and accelerated erosion

- Keep areas well vegetated to minimize soil erosion.
- Use *fencing* to keep horses out of highly erodible areas.
- Stabilize gullies as recommended by a professional. Options include headcut repair, *check dams*, grading side slopes and revegetating. See Section 4.1 for more information on these conservation measures.
- *Seed* and *mulch* bare areas to protect the soil from erosion and maintain desired grass species. (See Section 5.2 of the Resources Directory for seeding recommendations.)

### Grass Facts

Plants need energy for growth, maintenance, and reproduction. Green plants get energy from sunlight, *nowhere else!* Green leaves and stems act as solar energy collectors. Roots need the collected energy for growth and replacement. In general, large amounts of leaves and stems can provide energy for a large root system; small amounts of leaves and stems can only support a small root system. As a rule of thumb, the above ground portion of the plant is equal to the underground root system.

Severe grazing creates an imbalance between the energy provided by the plant's solar collector and the needs of the roots. If the solar collector is kept grazed, the root system will die back to match the energy available. Plants with small, shallow root systems will be far less productive or may even die. This is overgrazing. Overgrazing occurs plant by plant. Since horses are selective grazers, their preferred plants may be overgrazed even when the pasture as a whole looks ungrazed.

Adequate rest periods following grazing allow the plant to rebuild its solar collector and restore roots. The length of rest required will change as the growing conditions change. Grazing years should be planned to provide adequate recovery periods and minimize overgrazing of plants. Long periods of rest are sometimes damaging to individual plants and pastures if excessive thatch builds up. Balancing grazing and rest improves forage production and minimizes weed problems.<sup>8</sup>

<sup>8</sup>*How Grass Grows—The "REST" of the Story.* USDA Natural Resources Conservation Service.

## 2.7 Water Resources: Creeks, Springs and Wells. Managing Septic Systems

Water resources need special attention and protection. Healthy riparian areas along creeks and springs support a variety of plant and animal species, help control erosion, filter pollutants in runoff, and add beauty and diversity to the landscape. Creeks are vulnerable to erosion and other impacts from activities along streambanks. Creeks and smaller seasonal drainages transport pollutants downstream to lakes, larger streams and rivers, bays and eventually to the ocean. Every landowner can help maintain and enhance riparian areas. Springs provide water for wildlife and can be important sources of habitat for amphibians.

Wells tap into ground water for drinking water supplies and irrigation. Ground water resources are vulnerable to pollutants that can leach through the soil. Ground water also keeps dry-season flows (underground flows) in streams in some areas.

### Management Strategies for Surface Waters

#### Control horse access to springs, creeks, seasonal drainages, and ponds

- **Fencing** can be used to keep horses out of riparian areas.
- Graze riparian areas, if necessary, only during the dry season.
- Design **stream crossings** to minimize erosion. For more information, see Roads, Trails and Stream Crossings in Section 2.8.
- Develop alternative water sources for horse confinement areas that are located away from creeks and springs. Conservation measures to consider are **spring development** with buried **pipelines**, and **troughs**, extending existing water systems, installing **storage tanks**, and utilizing “nose pumps” where the animal presses a trigger to release water.

#### Manage runoff properly

- Set buildings, covered arenas, high-use areas, **horse wash areas**, **manure storage areas**, **roads and trails** back away from creeks.
- Prevent polluted runoff from reaching creeks and springs.
- Maintain a **filter strip** and/or **riparian buffer** between creeks and high-use areas.



*Restrict horses from creeks to help keep manure and urine from being deposited in creeks and minimize erosion on streambanks. Use **fencing** to help manage horse access to riparian areas. Riparian areas can be grazed seasonally when streambanks soils are dry enough to withstand trampling.*



*An alternative water source is critical if horses are restricted from creeks. Be sure to locate water troughs away from creeks, drainages, and springs. Try using a “nose pump” that allows horses to pump their own water.*

- Control erosion to reduce the amount of sediment that fills ponds.

### Monitor the creeks

- Landowners who wish to develop baseline data about the quality of water on their properties are encouraged to learn how to monitor their water resources. *Water quality monitoring* information is provided in Section 5.7 of the Resources Directory.
- Monitor water quality, especially during the rainy season.

### Enhance riparian areas

- Create and maintain a *riparian buffer* along the creek to help slow and disperse surface runoff, settle sediment, and filter pollutants. Use native plants to enhance wildlife habitat. (See Section 4.3 Riparian Buffer, for more information.)
- Monitor and stabilize streambank erosion. Seek professional advice for severe erosion and problems on larger streams. These areas may require intensive “bioengineering” or “hard” engineered structures (such as rock riprap) to stabilize the streambank, as well as a *riparian buffer*. Be sure to obtain required permits. For more information on streambank stabilization, see Section 4.1. For permit information see Sections 5.4 and 5.5 of the Resources Directory.
- Be aware of any habitat needs or areas for threatened or endangered species on your property. See Section 5.5 of the Resources Directory for more information.

## Management Strategies for Wells

Keep well water free of harmful contaminants for the health of you and your livestock. Improperly constructed or older wells can create a pathway for fertilizer, bacteria, nutrients, pesticides, or other materials to enter your water supply and the ground water. Once in the ground water, contaminants can flow from your property to a neighbor’s well, or from a neighbor’s property to your well. After your water becomes polluted, the only options may be to treat water after pumping, drill a new well, or get water from another source. Time and money spent protecting your well water is a bargain compared to the loss of clean water and an associated decrease in property value.

### Properly site wells

- Choose a location where surface water drains away from the well. Avoid placing wells in soil depressions.
- Be aware of how ground water flows. If you live in an area with a high water table (or if you have an existing shallow well), ground water often flows in the same direction as surface water. However, surface slope is not always a reliable indicator of ground water flow—meaning ground water may not always move downslope.
- Locate wells upslope of, and well away from, horse confinement areas, fuel tanks, septic fields, or pastures that may receive too much fertilizer.

- Check with your county permitting department for any well setback or well construction requirements and follow local regulations about the proximity of horse confinement areas to well heads.

### **Regularly test wells**

- Establish a water quality baseline to help detect changes.
- Test wells annually for the four most common indicators of trouble: bacteria, nitrates, pH, and total dissolved solids. A more complete water analysis will tell you about its hardness, corrosivity, iron, sodium, and chloride content. In addition, you may choose to obtain a broad scan test of your water for other contaminants such as pesticides. Local conditions may warrant additional testing.
- Talk to your neighbors. If they have had their wells tested, they may be able to provide you with information on water quality in the area. In addition, county or state health departments may have records of water quality tests in your area.
- Have older, shallow wells periodically checked by a qualified well driller or pump installer. Wells older than thirty years are apt to be shallow and more poorly constructed. Older pumps are more likely to leak lubricating oil. Older wells usually have thinner casings that may be cracked or corroded.

Older wells are more likely to provide a conduit for precipitation and runoff to reach the water table without being filtered through the soil. Wells have steel or plastic pipe “casings” to prevent the collapse of the well hole after drilling. The space between the casing and the sides of the hole are sealed with grout or bentonite clays and the well capped to prevent surface water from entering the well. The depth of the new seal depends on the soil type but should be at least twenty feet. Casing should extend at least 12 inches above the surface or 1 to 2 feet above the highest recorded flood level for the site. Contact county health or permitting departments for local specifications.

### **Keep well areas clean and accessible**

- Keep contaminants as far away as possible.
- Check nearby fuel tanks or septic systems on a regular basis.

### **Properly fill and seal unused and abandoned wells for safety, and to prevent waterborne pollutants from reaching ground water**

- Contact a licensed, registered well driller or pump installer for this work. A permit is normally required to assure proper well destruction.

## Management Strategies for Septic System Drainfields

Properly functioning septic systems depend on good dispersal of wastewater in the drain field and the ability of water to percolate through the soil at a steady rate.

Taking care of drainfields will enhance and preserve the ability of your septic system to break down potential contaminants (such as viruses, bacteria, nutrients, and organic waste) and keep them from contaminating ground water or nearby creeks.

- Keep drain fields covered with grass. Avoid planting trees and shrubs whose deep roots can damage pipes.
- Divert roof and surface runoff away from drainfields. Saturated soil is not effective for treating wastewater.
- Minimize activities that compact drainfield soils. Compaction decreases the ability of water to percolate through the soil, reduces the amount of oxygen available for waste-digesting microbes, and may shorten the life span of the drain field. Activities to watch include *grazing* and corrals directly over the leach field, particularly when soils are wet; vehicle use (which can also damage pipes); “high-use” horse activities; as well as paving, constructing buildings, and piling heavy objects.
- Nonstandard septic systems, such as mounds, at-grades, pressure distribution systems, sand filter, etc., can be especially fragile and should be well *fenced* for their protection. Local health or permitting departments can offer more specific advice.
- Follow local regulations about the proximity of horse confinement areas to septic leach fields.

## 2.8 Design and Maintenance for Roads, Trails and Stream Crossings

Proper road, trail and *stream crossing* design and maintenance will help control erosion. Improperly constructed or maintained roads can cause chronic erosion problems. Unsurfaced roads and horse trails can contribute sediment to creeks and can become dangerous or impassable for horses and vehicles. Even annual regrading of small washouts or eroded areas can contribute significant amounts of sediment to the nearest stream.

Develop longer-term solutions, such as a durable road base, compaction, and gravel surfacing to save time and money while reducing inconvenience, increasing safety, and controlling sediment from reaching creeks.

## Management Strategies for Roads and Trails

### Properly design and construct roads and trails

- Consider the type and amount of expected traffic, speed, loads, climatic conditions, and environmental resources in need of protection. Keep roads to a minimum, the fewer roads, the less maintenance and erosion. Follow sound engineering measures to insure that the road meets the requirements of its intended use and that maintenance requirements are in line with operating budgets. The *Handbook for Forest and Ranch Roads* is a good resource. To obtain this publication, call the Mendocino County Resource Conservation District at (707) 468-9223.
- Understand how roads are constructed and drained to help determine the appropriate strategy for your property. Roads are constructed to drain in three different ways:
  - ♦ **Insloped roads** are graded into the slope and drain to an inboard *ditch*. *Ditches* provide surface drainage for the roadway and should be designed to protect the road surface from upslope runoff.
  - ♦ **Crowned roads** are higher in the middle and drain water off to both sides. Crowned roads require more initial grading and regular *ditch* maintenance.
  - ♦ **Outsloped roads** follow natural drainage patterns and runoff drains across the road in even sheets. Typically, outsloped roads are less expensive to construct and easier and cheaper to maintain. *Culverts* and *ditches* are not required except where the road crosses small drainages. The addition of large amounts of stormwater runoff from above outsloped roads may cause excessive erosion. Roads may have to be surfaced, regraded, or re-routed.
- Develop adequate cross drainage. Long stretches of inboard *ditch* accumulate a lot of water that can cause extensive gulying of the *ditch*, destabilize the roadbed, and undermine the hillside. Some form of cross-drainage is required at regular intervals to channel runoff across the road to non-erodible outfalls, such as *energy dissipaters*, on the outboard side. Even if a road has some cross-drainage, additional measures may be needed to help prevent washouts. Selecting a method to transport water across a road depends on road location, amount of use and maintenance, the volume of flow, and budget considerations.

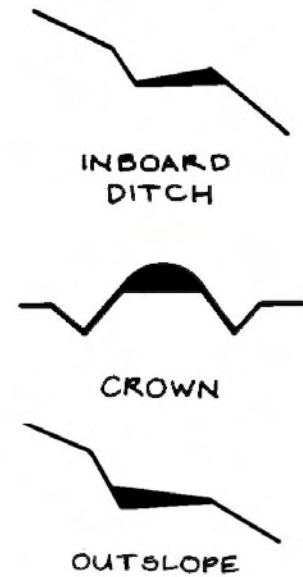

Roads are constructed to drain in three ways. Insloped roads are graded into the slope and drain to an inboard ditch. Crowned roads are higher in the middle and drain water off to both sides. Outsloped roads follow natural drainage patterns, and runoff drains across the road in even sheets. Outsloped roads are generally less expensive to construct and easier and cheaper to maintain.



A muddy swale is created by improper drainage from a road (uphill of this photo). A properly constructed and maintained road will help control erosion. Culverts and waterbars can provide cross-drainage. Some roads may need surfacing with gravel, while others should be avoided during the wet months.

Cross-drainage techniques to consider include:

- ♦ **Culverts.** Culverts are likely to need professional design to handle anticipated flow. Angle *culverts* about 30 degrees downgrade to assure proper water movement and prevent plugging and erosion at the inlet. Compact the backfill to prevent water from flowing through the road base. *Culverts* should be used in upland areas and avoided for *stream crossings*, where *bridges* are more appropriate.

Inlet and outlet design is important to prevent erosion. Inlet design must not allow “piping” (water flowing along the outside of the pipe) that could loosen the soil and wash out the pipe. *Culvert* outlets should extend at least two feet beyond the edge of the road and empty onto an *energy dissipater* (such as rock riprap). For outlets on steep slopes, use a *lined waterway* or *underground pipeline* to safely convey water to the base of the slope.

- ♦ **Rolling Dips** are dips in the grade of the road. Rolling dips are installed in a road bed to drain the road surface and prevent rilling and surface erosion, and are most frequently used on outslopped roads. To effectively direct runoff to the side of the road, the axis of a rolling dip should be angled about 30 degrees to the road alignment.

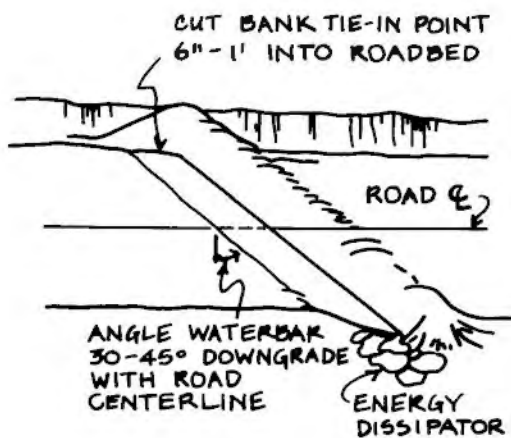

- ♦ **Waterbar.** This is a shallow ditch placed 30 to 45 degrees downslope across the road surface to control surface runoff on low use roads. The excavated material from the *waterbar* is piled in a rounded *berm* downslope of the waterbar to form an additional water barrier. *Waterbars* are a temporary and very effective means of breaking up surface flow on sloped portions of road. Often they must be reconstructed every year as they wear down.

*Waterbars* work best on roads that receive little winter traffic. In a pinch, they can be constructed with hand tools. Installing a series of *waterbars* reduces the flow volume individual *waterbars* must handle. *Waterbars* can be reinforced with logs, gravel, or a mixture of soil and cement.

♦ Follow natural contours and slopes to minimize disturbance of drainage patterns. Avoid building roads on unstable slopes or at too steep of a grade. Grades normally should not exceed 10 percent slope

except for short lengths. Minimize cuts and fills, and stabilize the side-slopes of all cuts and fills. Areas with geological hazards (such as old landslides) should be avoided.

Set roads and trails back from creeks and maintain a *riparian buffer*.

**Waterbars** are a temporary form of cross-drainage. To create a *waterbar*, dig a shallow ditch 30 to 45 degrees downslope across the road. Pile the excavated material in a rounded *berm* downslope of the *waterbar*. *Waterbars* need to be monitored and maintained throughout the winter.

Set roads and trails back from creeks and maintain a *riparian buffer*.

### Maintain roads, trails, culverts, and ditches

- Go out during a storm, shovel in hand, when you can see drainage patterns and areas that require urgent attention.
- Check for erosion and drainage problems, particularly on road surfaces, *ditches*, and cross-drainage structures. Often the main cause of soil erosion is from the power of concentrated runoff that roads and trails collect and channel.
- Look for *ditches* or *culverts* that are washed out, blocked with debris, or are causing downstream erosion at the outlet.
- Keep *ditches* vegetated with grass to help maintain stability.
- Keep *ditches* cleared of sediment. Vegetated *ditches* with a gentle slope of 2 to 6 percent will prevent sediment deposition and allow rapid drainage. For chronic sediment problems, address the erosion source.
- Keep inlets clear. Remove debris before the rainy season and check during and after storms. Look upstream for any material that could wash into the *culvert*. Consider another method of cross-drainage or address the upstream source of debris if *culverts* plug after every major storm.
- Consider using *trash racks* to trap debris, if you can maintain them. While trash racks can help keep *culverts* open, unmaintained racks can cause more erosion problems than the original debris.
- Control upslope erosion sources to prevent sediment from filling cross-drainage *culverts*.
- Install and maintain *energy dissipaters* at outlets.

### Maintain and improve road and trail surfaces

- Regrade roads to smooth the surface and prevent rills from expanding.
- Provide adequate cross-drainage using *culverts* and *waterbars*.
- Resurface roads and trails that have high traffic, chronic erosion problems, undesirable amounts of dust, or steep grades. For muddy roads, consider using a gravel road base laid over a layer of filter fabric to prevent the gravel from mixing with mud.
- Limit or avoid using certain roads and trails during the winter, particularly those on highly erodible soils.
- Limit side-trails where possible. Shortcuts, especially up steep slopes and across streams, can create highly erodible sections of trail. Encourage riders to stay on established trails.
- Sow grass seed on seldom-used roads and adjoining areas of exposed soil. *Seeding* should occur before October 15 to ensure adequate growth.



*A rock-lined ditch is necessary along this steep road. Well-constructed and maintained ditches are key to the long-term stability of an insloped or a crowned road.*



*Roads not used in the winter can be “put to bed” for the season. This road has been seeded and will not be used again until the spring. Roads should be properly graded, seeded and mulched, to help prevent erosion. **Seeding** should occur before October 15 to ensure adequate growth before the winter rains.*

### Put abandoned roads “to rest”

- Grade, *seed* and *mulch*, or use an *erosion control blanket* when putting roads to rest for the rainy season. Jute netting with a layer of straw underneath can also be used. Straw wattles (bundles) can also help with erosion control. (For information on *erosion control blankets* and straw wattles, see Section 4.1: Erosion Control – Gully Repair.) For roads with chronic erosion problems, laying roads to rest may be an appropriate strategy from an economic, environmental, or safety standpoint.

### Stream Crossings

- Select an appropriate crossing (either a *bridge*, *rolling dip*, *ford*, or *culvert*). Select a crossing location that will least impact streambanks and riparian vegetation.



*This stream crossing keeps livestock from trampling the streambanks. Stream crossings, such as **bridges**, **fords** and **culverts**, should be located and designed to minimize impacts to streambanks and riparian plants. Bridges work best on larger streams and have the least impact on aquatic life. Permits are generally required.*

- ♦ *Culverts* should be properly sized and installed. They should follow the same alignment as the creek and exit at the same level as the channel downstream.

- ♦ *Fords* may be required for crossing small seasonal drainages or where debris can clog *culverts*. *Fords* should be surfaced with concrete to prevent erosion. *Fords* require site-specific engineering design. A correctly designed *ford* should require very little maintenance. If horses will use the *ford*, be sure to roughen the concrete surface, when pouring the concrete, for traction.

- ♦ *Bridges* are best for larger streams and where there is a lot of floating debris. *Bridges* have fewer impacts on aquatic life than other crossings.

- Remember *ditches* in the design process. Well-constructed and maintained *ditches* are key to the long-term stability of an insloped or a crowned road. Slope the sides of drainage *ditches* if possible to control erosion. *Ditches* on steeper slopes may need to be lined with rock. Steep-side *ditches* will erode more easily than those with 2:1 side slopes. Flat-bottomed *ditches* with a 1-2 foot wide bottom are less subject to scouring than V-bottom ditches. *Ditches* on steep slopes may require *check dams* for grade control (you may want to consult a professional for advice and design).
- Stream crossing references. Check these internet reference sites for additional information on designing stream crossings for fish passage:

National Marine Fisheries Service  
<http://swr.nmfs.noaa.gov/habitat.htm>  
 Click on Stream Crossing Guidelines

Washington Department of Fish and Wildlife

<http://wdfw.wa.gov/recovery.htm>

Click on Fish Passage Design at Road Culverts

- Obtain necessary permits. County, state, and federal ordinances regulate many aspects of road construction, reconstruction, and maintenance. Creek crossings will likely require a Streambed Alteration Agreement from the California Department of Fish and Game and can require permits from the US Army Corps of Engineers and the Regional Water Quality Control Board. County public works and building departments may have grading ordinances that describe how roads may be constructed and connected with existing public roads. Other state regulatory agencies with jurisdiction on road construction and related activities include the California Department of Transportation, California Department of Forestry and Fire Protection, and California Coastal Commission (for work in the Coastal Zone). See Sections 5.4 and 5.5 of the Resources Directory for more information on regulations and permits.
- Schedule construction and maintenance activities to minimize soil erosion and allow for revegetation of disturbed areas before winter rainfall. Although some soil moisture is advantageous for roadbed compaction, wait until winter runoff has slackened and soils have begun to dry in the late spring before beginning construction. Heavy equipment should not be used on wet soils. Prevent sediment from entering creeks during and after construction. After construction, revegetate road banks and disturbed areas before the winter rains. **Seed** and **mulch** for revegetation by October 15.

## 2.9 Construction Management

Proper construction is important whether building a new horse facility or making improvements at an existing facility. Appropriate installation of erosion control and drainage structures can help protect water quality and reduce future maintenance.

### Construction Management Strategies

- Seek technical advice and professional design assistance. Drainage systems must be sized for water volume and velocity.
- Obtain the proper permits for grading and working in streams. See Sections 5.4 and 5.5 of the Resources Directory for more information.
- Avoid grading during the rainy season.
- Minimize disturbance along the edges of creeks.
- Be sure equipment operators fully understand the purpose and extent of grading. Flag-off special areas that you want to protect.
- Implement erosion control measures, such as *seeding* and *mulching* or installing *erosion control blankets*, immediately following grading. Utilize emergency measures such as *straw bale sediment barriers* until permanent structures can be installed.
- Monitor and maintain all erosion control measures.



## Chapter 3

# List of Conservation Measures

A conservation measure is a specific treatment, such as a management decision, activity, practice, or structure, that provides a practical, effective, and economical means to prevent or reduce water pollution. Protecting creeks and water quality can create a healthier environment for horses by reducing mud and manure areas.

Table 2 lists conservation measures discussed throughout this guide in ***bold italic*** and identifies the main section(s) in which they are found. Note that conservation measures and suggestions in this guide rely extensively on the standards and specifications of US Department of Agriculture's Natural Resources Conservation Service.<sup>9</sup> Horse owners may need to seek professional assistance with some measures. Conservation measures with an asterisk (\*) have an NRCS standard and specification with specific design criteria. Some standards and specifications have different names than used in this guide, which are marked with a footnote, and NRCS practice names are given at the end of the table. Visit the website: <http://www.nrcs.usda.gov/technical/efotg/>, or contact your local NRCS office for details.

<sup>9</sup> Conservation practices in this section are drawn from USDA Natural Resources Conservation Service *Field Office Technical Guide*. Davis, CA, 1986.

**Table 2: Horse Keeping Conservation Measures**

<b>Conservation Measures</b>	<b>Section</b>	<b>Page Number</b>
<i>Conservation plan</i>	1.1, 2.3	11, 24
Erosion control Conservation Measures	4.1	52
<i>Seed</i> <sup>A*</sup>	4.1, 5.2	52, 79
<i>Mulch</i> <sup>B*</sup>	4.1, 5.2	52, 80
<i>Erosion control blanket</i> <sup>C*</sup>	4.1	53
<i>Gully repair</i>	4.1	53
<i>Check dam</i> <sup>D*</sup>	4.1	60
<i>Streambank stabilization</i> <sup>E*</sup>	4.1	55
Emergency Erosion Control Measures	4.1	58
<i>Sandbag</i>	4.1	59
<i>Sandbag pipeline drop inlet</i>	4.1	61
<i>Silt fence</i>	4.1	61
<i>Straw bale check dam</i>	4.1	60
<i>Straw bale sediment barrier</i>	4.1	60
<i>Straw bale waterbar</i>	4.1	59
Road Related Erosion Control <sup>F*</sup> including Stream Crossing	2.8	40
<i>Bridge</i>	2.8	44
<i>Ford</i>	2.8	44
<i>Culvert</i>	2.8	41
<i>Ditch</i>	2.8	41
<i>Waterbar</i>	2.8	42
<i>Trash rack</i>	2.8	43
<i>Stream Crossing</i>	2.8	44
Pasture Management	2.6	32
<i>Fence*</i> or <i>cross-fencing</i>	2.6	33
<i>Grazing distribution</i> <sup>G*</sup>	2.6, 5.8	33, 94
<i>Rotation grazing</i> <sup>G*</sup>	2.6	34
<i>Spring development*</i>	2.7	37
<i>Storage tank</i> <sup>H*</sup>	2.7	37
<i>Trough*</i>	2.7	37
<i>Monitor grass growth</i>	2.6	34
<i>Residual dry matter;</i> <i>monitoring grass residue</i>	5.8	93
<i>Manure spreading</i> <sup>N</sup>	2.3	27
<i>Weed management</i>	2.6	33

<b>Conservation Measures</b>	<b>Section</b>	<b>Page Number</b>
Stormwater Management Measures (Keep “Clean” Water Clean)	2.1, 2.2	20, 21
<i>Roof runoff management*</i>	2.1, 4.2	20, 62
<i>Gutter</i>	2.1, 4.2	20, 62
<i>Downspout</i>	2.1	20
<i>Splash pad</i>	2.1	20
<i>Subsurface drain*</i>	2.1	20
Runoff Diversion	4.2	63
<i>Diversion*</i>	4.2	63
<i>Berm</i>	4.2	63
Runoff Conveyance	4.2	63
<i>Grassed waterway*</i>	4.2	64
<i>Lined waterway*</i>	4.2	65
<i>Drop inlet</i>	4.2	65
<i>Sediment basin*</i>	4.2	65
<i>Underground pipeline*</i>	4.2	65
Discharge Area	4.2	66
<i>Energy dissipater<sup>I*</sup></i>	4.2	66
Polluted Water management measures	4.3	66
<i>Filter strip*</i>	4.3	66
<i>Riparian buffer*</i>	4.3	67
<i>Willow sprigging<sup>J*</sup></i>	4.3	71
<i>Constructed wetland*</i>	4.3	72
<i>Waste pond*</i>	4.3	72
<i>Pond sealing or lining*</i>	4.3	72
<i>Horse wash area</i>	2.5	31
<i>Paddock</i>	2.6	35
<i>Turnout</i>	2.6	35
<i>Water quality monitoring</i>	5.7	90
Manure Management <sup>K*</sup>	2.3	24
<i>Manure storage area<sup>L*</sup></i>	2.3	24
<i>Manure transfer* or hauling</i>	2.3	28
<i>Manure application<sup>M,N*</sup> or spreading</i>	2.3	27
<i>Composting manure</i>	2.4	29
<i>Compost area<sup>O*</sup></i>	2.4	30
<i>Water quality monitoring</i>	5.7	90

**Natural Resources Conservation Service names  
for standards and specifications:**

- A* Critical area planting
- B* Critical area planting – straw mulch
- C* Critical area planting – erosion control blanket
- D* Grade stabilization structure
- E* Streambank protection
- F* Access road
- G* Prescribed grazing
- H* Trough or tank
- I* Rock riprap
- J* Critical area planting – woody cuttings
- K* Waste management system
- L* Waste storage facility
- M* Nutrient management
- N* Waste utilization
- O* Composting facility



## Chapter 4: Conservation Measures to Improve Water Quality

Conservation measures offer options for making improvements at a horse facility and are designed to assist land users to effectively reduce sources of pollution at horse facilities. You have seen the list of conservation measures (Chapter 3) and references to these conservation measures in Chapter 2. Material in this chapter is designed to assist horse owner knowledge and understanding of how management practices function together within a facility. Now, we will discuss in detail how the items tie together.

This chapter is presented in three sections:

- **Section 4.1:** Erosion Control Conservation Measures
- **Section 4.2:** Stormwater Management Measures:  
Keep “Clean” Water Clean
- **Section 4.3:** Measures to Manage “Polluted” Water

## 4.1 Erosion Control Measures

Erosion is easier to control in its early stages when revegetation or simple drainage improvements may be all that are necessary. Once eroded, soils are less productive, and can be more difficult to revegetate. Watch for accelerated erosion in vulnerable areas such as steep slopes and landslides, pastures, gullies, intensively used horse areas such as *paddocks* and *turnouts*, streambanks, unsurfaced roads, road cuts, parking lots, and construction areas.

### Seed and Mulch for effective Revegetation



Straw mulch is being applied after tractor work was done to smooth out a gully. **Seeding and mulching** are effective and low-cost erosion control measures. When seeding and mulching bare areas, be sure to prepare the seedbed by removing weeds, and roughening the seedbed. Grass seed should be spread by October 15. Mulch should be weed free.

**Seeding** and **mulching** provide effective revegetation.. **Seeding** is usually needed for **filter strips**, **grassed waterways** and **pastures**, as part of erosion control, or after construction. A complete seed mix and specifications are in Section 5.2 of the Resources Directory. **Seeding** and **mulching** tips to keep in mind are:

- Be sure to plant before the rainy season, generally by October 15.
- Properly prepare the seedbed. The area should be weed free. Have a firm seedbed that has been roughened by disking, harrowing, or a similar method. Or use a no-till drill to seed directly into existing grasses, which will minimize erosion.
- Legumes (clovers) must be inoculated with nitrogen fixing bacteria immediately before planting. This will help increase legume production and nitrogen fixation. (See Section 5.2, Legume Inoculation.)
- Maximize the use of native species.
- Do not use fertilizers with native grasses, as weedy annuals will compete for the extra nutrients.
- Use **mulch**, preferably straw, after seeding. Crimp the straw with a shovel for small areas, or a tractor with tracks for large areas, to anchor it in place. Make sure straw is certified weed free. Rice straw is a good option because the weeds that grow with rice only survive in an aquatic environment.
- Straw wattles can be used to break-up the rainfall over long slopes.
- Keep the soil moist until the rainy season begins.
- Periodically mow or graze, and weed to control noxious weeds and reduce fire danger.
- Restrict human and horse access until grasses are well established.

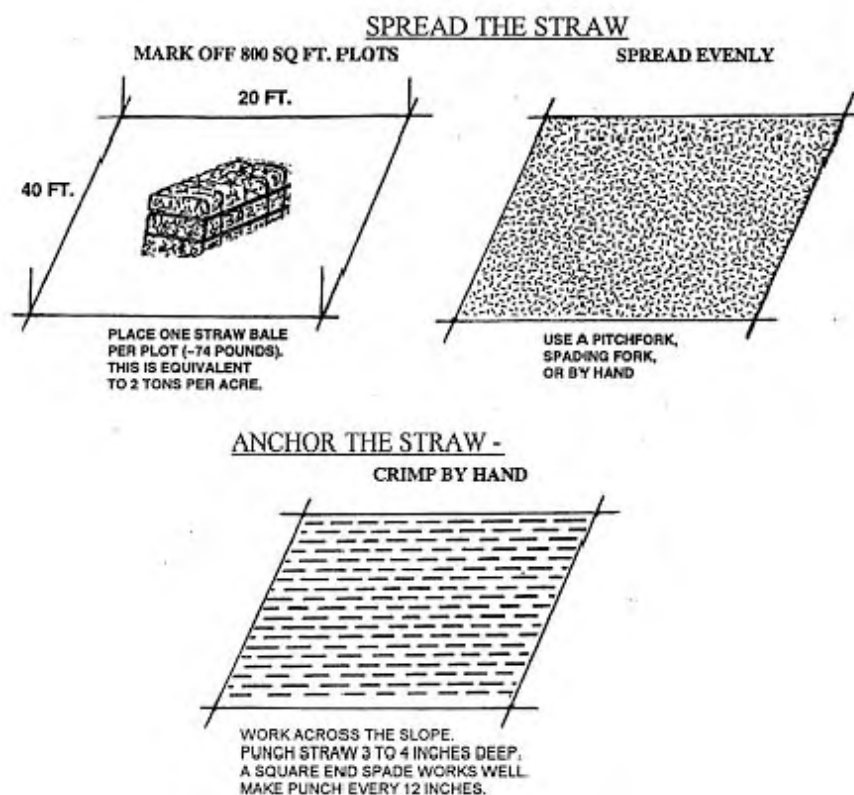

Apply straw mulch at a rate of two tons per acre (or one 74 pound bale per 800 square feet, at a uniform depth of 2 to 3 inches). Straw can be anchored by hand punching, or in larger areas, by using rollers, crimpers, or a disk.

## Gully Repair

Certain highly erodible soils are particularly susceptible to gully formation. Gullies will deepen and widen if left unchecked. To develop an effective repair, determine what caused the gully to form. Any change in drainage patterns that concentrate water, such as *ditches* or road *culverts*, are likely suspects and may be easy to remedy.

Steps to stabilize a gully include: 1) stopping the gully headcut, so it will not continue to move uphill, and 2) controlling the gully downcut so it will not continue to deepen and widen. Options for *gully repair* include one or more of the following: *fence* livestock out, install a *grassed waterway* or *lined waterway*, line the headcut with rock to keep it from moving upslope, install rock *check dams* to stop downcutting, grade side slopes and *seed* and *mulch* the area. *Erosion control blankets*, and straw wattles may also be needed. Avoid using *erosion control blankets* with plastic netting as birds and other small animals can become trapped in the mesh.



A gully headcut needs stabilization to keep it from moving upslope. Measures are also needed to control deepening and widening of the gully. Horses should be restricted from gullies as trampling can exacerbate erosion problems or damage repairs.

**Erosion Control Blankets** are effective tools for the prevention of erosion. Erosion control blankets are made from bio-degradable substances such as straw, coconut, or wood fiber, bonded in place with a variety of netting and stitch patterns. Erosion control blankets are placed onto prepared, seeded, soils to prevent washing away of the seed and erosion of the prepared seed bed. After the vegetation grows the erosion control blanket degrades over time until only the vegetation is left in place. The vegetation, once established, provides permanent erosion control. Erosion control blankets are available in a variety of sizes and grades. For photos and installation recommendations, search “erosion control blanket” on an internet search site for various vendors.

**Straw wattles** are man-made cylinders of compressed, weed-free straw (wheat or rice), 8 to 12 inches in diameter and 20 to 25 feet long. They are encased in jute, nylon or other photodegradable materials, and have an average weight of 35 pounds. They are installed in a shallow trench forming a continuous barrier along the contour (across the slope) to intercept water running down a slope. Straw wattles are used to increase infiltration, reduce erosion, and help retain eroded soil on the slope. Straw wattles should be effective for a period of one to two years, providing short-term protection on slopes where permanent vegetation will be established to provide long-term erosion control. Search “straw wattles” on an internet search site for various vendors.

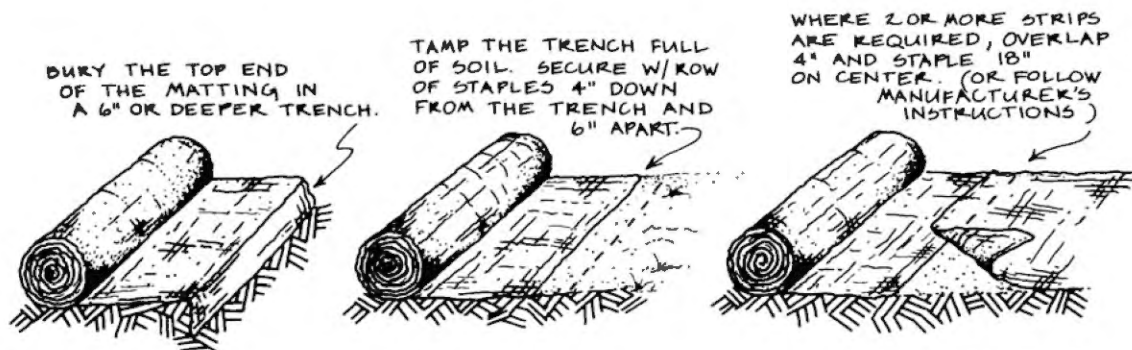

**Erosion control blankets** must be carefully installed to be effective. Make sure the upper end is securely tucked into a small trench. Blankets range from simple jute netting that works best if straw is laid underneath, to heavy duty coconut fiber. Avoid using blankets with plastic netting as birds and small animals can become trapped in the mesh.

You will likely need technical assistance before attempting to repair a gully. *Groundwork: A Handbook for Erosion Control in Northern California* contains hands-on, practical advice. Contact the Marin County Resource Conservation District at 415-663-1170 to obtain or review a copy.



*It is easier to stabilize a small or beginning gully than to repair a large gully system. Where is the runoff coming from? Can it be diverted? Should it go into an underground pipe? Or perhaps careful placement of rock and proper use of erosion control fabrics will make a successful project. Site specific recommendations are needed for gullies.*



**Rock check dams** are a common gully repair. **Gully repair** is site-specific, so obtain technical assistance. Be sure to acquire any permits from the county, California Department of Fish and Game, Regional Water Quality Control Board, and the US Army Corps of Engineers. Continue to monitor and maintain your projects after installation.

## Streambank Stabilization<sup>10</sup>

Evaluate and determine the cause of the problem. Streambank erosion may be caused in three ways or by a combination of the following processes:

**Surface flow.** Water flowing over the top of the ground usually causes steep, vertical bank erosion. Common sources include *culverts*, driveways, *ditches*, or drainage from roofs. Addressing the cause, either by redirecting or slowing the flow and dissipating its energy, will go a long way toward solving the problem.

**Ground water.** Water flowing a few inches to a few feet below the ground frequently surfaces (or “daylights”) on a streambank before reaching the creek channel. This makes streambanks vulnerable to erosion. Although ground water flow can cause or exacerbate erosion, it can also be an asset if you plan to control erosion using vegetative methods. Check to make sure you are not indirectly contributing excess subsurface flow through irrigation.

**Stream dynamics.** Natural changes—such as big storm events or human activities—can cause the stream channel to adjust. For example, when areas are paved and vegetation is removed to construct buildings and roads, less water soaks into the soil and run-off is increased. This increases storm flows and contributes to flooding problems. Removing vegetation along a creek can reduce streambank stability. This can lead to streambank failure, particularly during major storm events.

Once you have determined the cause of the streambank erosion, you can plan, install, monitor and maintain your repair.

<sup>10</sup> This information was drawn from the Marin County Stormwater Pollution Prevention Program brochure, *Repairing Streambank Erosion*. 1997.

### Determine if the site needs repair

Not all erosion is bad. Streams need to be able to adjust to events in the watershed by changing their shape. Undercut banks and fallen trees provide important habitat for aquatic life. Erosion should be controlled if it threatens a structure, road, utility pole, other property, or prime riparian habitat; is extremely active; or is caused by a human factors (such as a road).



*Plant grasses and shrubs (preferably natives) on streambanks to reduce erosion. Streambanks with sparse cover are a common source of erosion. Eroding areas should be repaired if they threaten a structure, road, utility pole, other property, or prime riparian habitat; is extremely active; or is caused by a human-made change, such as a road.*



*When undertaking a **streambank repair** project, take photos and make sketches of the site, seek professional assistance for major or complex repairs, incorporate native plants into projects, and be sure to obtain the proper permits. Monitoring and maintenance is critical during the first few years after installation.*

### Document the site

If you repair the erosion site yourself, you will need information for calculating materials and getting permits. If an engineer or agency is helping you, this information will save them time and you money. Take photographs (and include a reference object such as a fence line or tree), sketch the site including measurements and any biological information you have, and note any observations you have of the situation.

### Determine if this should be a cooperative project

If many of your neighbors have similar streambank erosion, consider working together. Benefits include sharing the permit and planning costs, building repairs that complement and even enhance each other, and, if done in conjunction with a local agency or group, may be eligible for private or government grant programs.

### Determine if you need professional help

Consider professional help when the repair is major, and/or an ineffective repair could result in significant damage to a structure, road, or other valuable property; working space is limited; and county regulations and common sense dictate professional design. Civil engineers, biologists, and other restoration specialists can help design repairs. Ask the individual or firm if they have done this type of work before. When, where, and for whom? How do they plan to repair the site? How will they access the site? What type of equipment will be used? How long will the work take? What is the estimated cost of designing and constructing the repair? Can they assist you in obtaining

permits? Visit project sites that they have repaired, and discuss the project with the landowner.

### **Consider a range of design options**

Find out what has worked in your area. Be sure **not** to constrict the channel. Keep fish and wildlife habitat in mind. (For stream crossing information, see Section 2.8 on Roads.) If salmon or steelhead passage is expected, follow *culvert* design guidelines by the California Department of Fish & Game and the National Marine Fisheries Service. Also, your local Resource Conservation District, or the Natural Resource Conservation Service are good sources of information. See Section 5.1 of the Resources Directory for contact information.

Incorporate native plants into the repair. The extensive root systems of some native plants can help with streambank stability. Even rock riprap can be interspersed with willows or other trees to enhance habitat. Willow wattle walls, brush mattresses, and other techniques described in *Groundwork: A Handbook for Erosion Control in Northern California* can stabilize streambanks completely with *live* materials, which is preferable.

### **Obtain necessary permits**

Acquire permits before construction. Most stream repair work requires a Streambed Alteration Agreement from the California Department of Fish and Game. Most counties require grading or building permits for work in stream channels. Permits will likely be required from the US Army Corps of Engineers and the Regional Water Quality Control Board. See Sections 5.4 and 5.5 of the Resources Directory for permit information.

### **Install your project properly**

Streams are a demanding and often unforgiving work place. Never underestimate the force of moving water. Pay attention to small details that will make the difference between a successful repair and a headache. Follow all permit requirements. Most work will need to be completed by October 15. See Section 2.8 for Stream Crossing references.

### **Monitor and care for your repair**

Many failures are caused by small problems that could have been avoided if caught early. Check your repair before the winter rainy season, and during and after each storm. Establish a location where you can take “before” and “after” photos.

## Emergency Erosion Control Measures

The emergency erosion control measures described in this section are temporary actions that property owners can install themselves. These measures are low-cost, and often do not require special expertise to design or install. However, they require constant maintenance and generally last only one season. They are designed to retain or divert stormwater runoff, reduce flood damage, stabilize overwhelmed drainage structures, or stop erosion. It is best to put in erosion control measures before the rainy season, although these measures can be installed anytime you notice a problem or potential problem.

All of these measures should be considered temporary until access, weather, time, or money allows more permanent solutions to be implemented. For example, straw bales usually rot after one year. Proper companion measures may also be necessary if the temporary fix fails (which often happens), and then creates a bigger problem. It is important to develop long-term solutions for erosion sites.

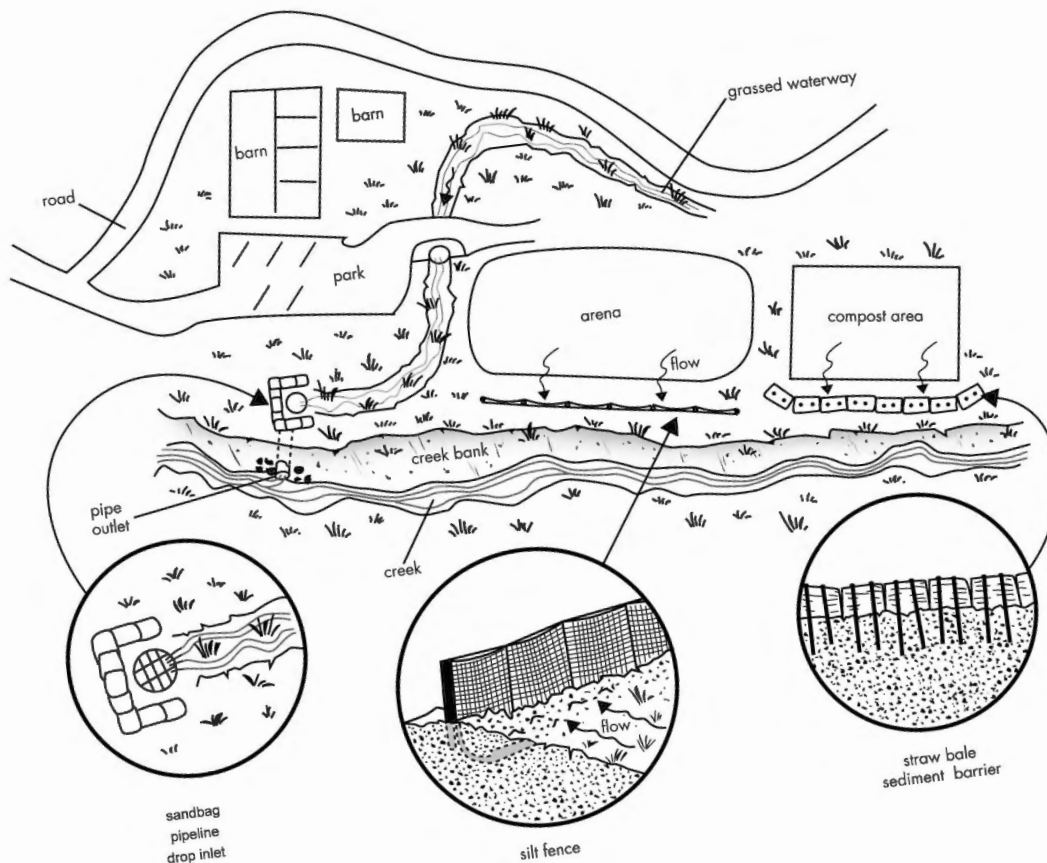

**EMERGENCY MEASURES** – Use emergency erosion control measures to divert stormwater runoff, reduce flood damage, stabilize overwhelmed drainage structures, or stop erosion. Temporary measures to consider are **sandbag pipeline drop inlets**, **silt fences**, and **straw bale sediment barriers**. All require proper installation and maintenance, and should be replaced with permanent measures as soon as possible.

Emergency measures must be properly installed and maintained. This will minimize the chance of failure and avoid causing greater problems on-site or on neighboring land. You may need to seek technical assistance from qualified consultants, Natural Resources Conservation Service, or your local RCD. Remember, each site is unique and some temporary measures may not be appropriate for your property.

During the winter, keep a close eye on drainage conservation measures and known problem areas. Immediate action can prevent problems from becoming larger or causing more damage. Be prepared to act quickly by keeping materials to construct emergency measures on hand. Materials commonly needed for emergency measures include straw bales, straw *mulch*, *sandbags* and fill material, *erosion control blankets*, plastic tarps, *silt fences*, steel t-posts or rebar, fence mending supplies, baling wire, rope, and rock.

These measures should not be put in creek beds, but in upslope areas. The following are emergency erosion control measures to consider.

### Sandbags

These are used to direct runoff into *culverts* and *drop inlets* or other conveyance structure. Abut the ends of *sandbags* tightly against one another and overlap joints.

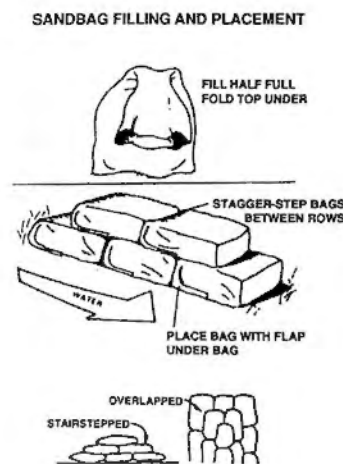

*Sandbags can be used to direct runoff into culverts and drop inlets. Be sure to abut the ends of sandbags tightly against one another and overlap joints.*

### Straw bale waterbars

These are also used to divert water off road surfaces. Straw bales used as *waterbars* should be installed at a slight angle down the slope of the road. Straw bales should be placed in a trench at least 4 inches deep with the excavated material used to form an earthen *berm* against the uphill side of the bales. Drive rebar or t-posts through each bale and at least 1 to 2 feet into the ground. Angle the first stake toward a previously laid bale to force the bales together. Abut the ends of straw bales tightly against one another. Loose straw can be crammed between bales to help seal joints. Overlap joints by at least 15 inches if more than one row or layer of straw bales are used.

Straw bales are subject to damage by curious and hungry livestock and deer and may need to be protected with chicken wire.

A straw bale *berm* can also be used as an emergency *waterbar*. To divert water, angle the *berm* and trench slightly down and across the slope. Place the excavated material in a *berm* on the downslope side of the trench. Protect the outlet from erosion with gravel. See Section 2.8 for more information on road and trail maintenance.

### Straw bale sediment barriers

These are used to retain sediment while allowing water to infiltrate through.<sup>11</sup> Install and anchor straw bales as described (in *straw bale waterbar*). Care should be taken so runoff does not backup behind the barrier and flow around the ends where the concentrated water can cause erosion.



A **straw bale sediment barrier** retains sediment while allowing water to pass through. Bales need to be anchored with stakes or rebar. Be sure that water cannot flow around the barrier and cause downslope erosion.

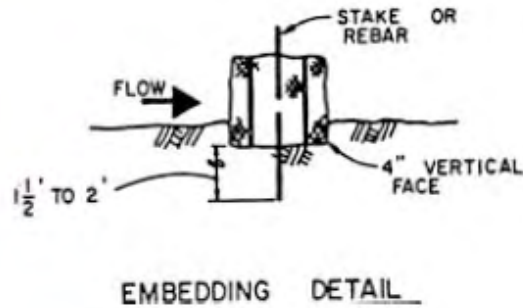

When using straw bales as a **waterbar** or sediment barrier, place bales in a trench at least 4 inches deep. Drive two metal fence posts or rebar for stakes through each bale and at least 1 to 2 feet into the ground.

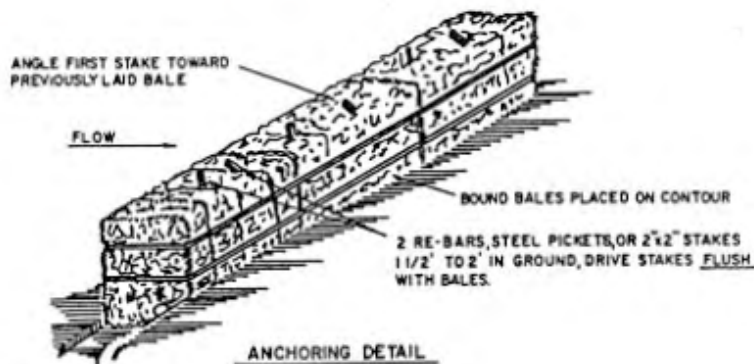

Abut the ends of straw bales tightly against one another. Angle the first stake toward a previously laid bale to force the bales together. Cram loose straw between bales to help seal joints. If using two rows stacked (one atop each other), overlap the joints by at least 15 inches or more.

### Straw bale check dam

These can be used to stabilize eroding gullies and ditches. **Straw bale check dams** in gullies and ditches are prone to failure and can cause worse erosion problems unless properly installed. Have them installed by an experienced person, or gather further information from NRCS.

**Table 3. Straw bale check dam – design limits**

Slope	Maximum Drainage Area	Maximum Slope Length Between Check Dams
0 – 15%	1 acre	200 feet
15 – 20%	½ acre	100 feet
>20%	Not Recommended	—

<sup>11</sup> Emergency barrier structures can typically contain the stormwater runoff from one acre and 100 feet of slope length for slopes up to 15 percent; or one-half acre and 50 feet of slope length for slopes greater than 15 percent.

### Silt fences

As with *straw bale sediment barriers*, the purpose of these structures is to settle out sediment in sheet flow, not concentrated flow, while allowing water to pass through. Again, care should be taken so runoff does not pond behind the *silt fence* and flow around the ends where the concentrated water can cause erosion. *Silt fences* less than 4 feet in height can be supported by sturdy wire fencing, such as woven wire, stapled to 4 x 4 wooden posts set at least 2 feet into the ground and four feet apart. Place the fabric on the upslope side of the fence and staple to the posts. At least 12 inches of the fabric and 4 inches of the wire should be buried in a 3-6 inch deep trench. Backfill and compact the trench.

Other types of fabric less than one-foot in height need to be supported by galvanized cable stretched between one-inch galvanized steel pipes driven at least three feet into the ground. The cable runs through sewn loops in the fabric. At least 12 inches of the bottom of the fabric is buried in a trench at least 6 inches deep and backfilled with compacted soil.

### Sandbag pipeline drop inlet

*Sandbags* can be used to direct runoff into *culverts* and *drop inlets*. Be sure to tightly abut the ends of the *sandbags* and overlap any joints.

## 4.2 Stormwater Management Measures: Keep “Clean” Water Clean

It is much easier to manage “clean” water than to treat water once it becomes polluted. Monitoring your water is a good way to see if you are keeping it clean. It is just as important to limit the impacts of smaller, more frequent storms, as it is to address the typical flooding and drainage problems that occur with larger storms. Runoff must be collected, or diverted, conveyed, and then safely discharged. Remember to incorporate erosion control into your stormwater management.

Conservation measures covered in this section include:

- Runoff Collection
- Runoff Diversion
- Runoff Conveyance
- Discharge Area

### Roof Runoff Collection

Collection of runoff is required if rain that falls on roofs drains to areas where it may come in contact with horse waste or cause soil erosion. This is most commonly needed where *paddocks* are attached to stalls in a barn. Three conservation measures to consider are *gutters*, *downspouts*, and *splash pads*.

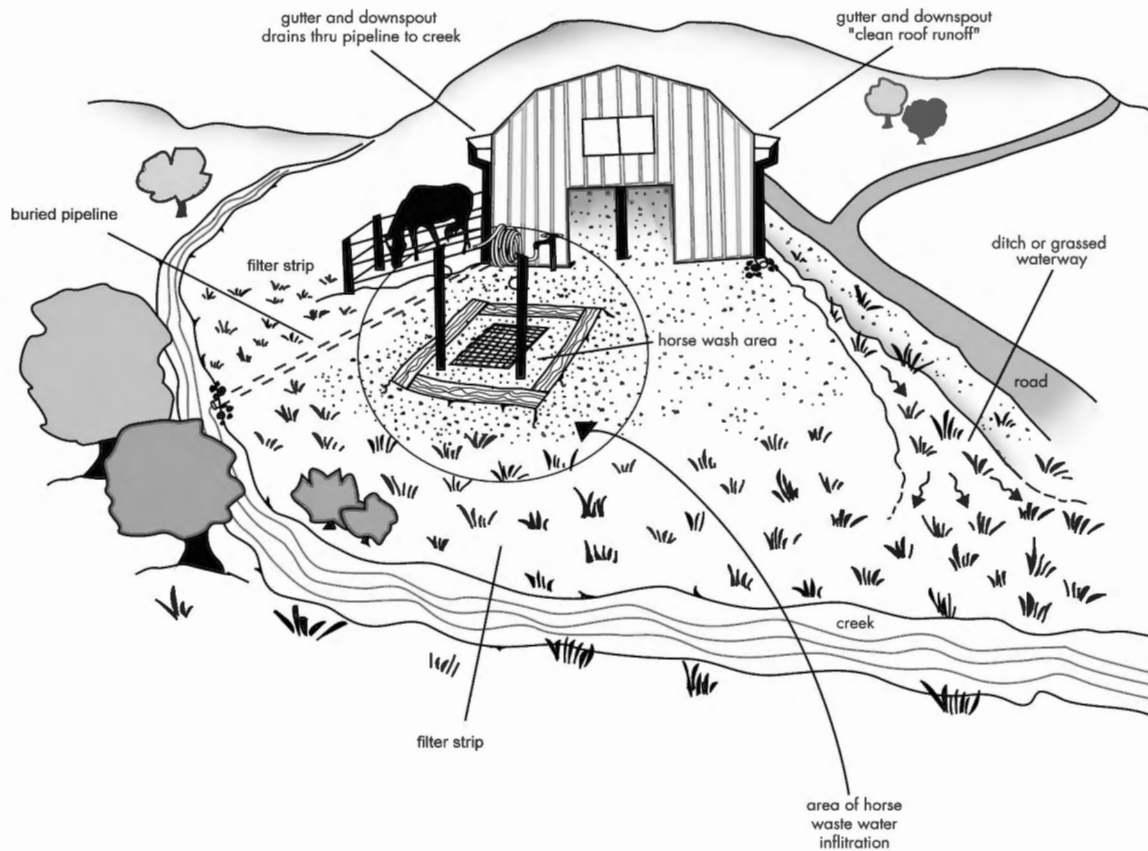

**STORMWATER MANAGEMENT** – Managing runoff from roofs will help keep “clean” water clean. **Gutters and downspouts** can direct clean stormwater away from bare or manured areas. **Diversions or berms** can direct water away from buildings. **Buried pipelines** can convey clean water to a creek. **Polluted runoff from a horse wash area** should flow into a **waste pond** or through a **filter strip** before it reaches a creek.

### Gutters

Size **gutters** to handle the volume of rainfall calculated for the roof size. **Gutters** should have sufficient support to withstand anticipated water. You may need to seek professional help for gutter and downspout sizing. **Gutters** may not be required if roof runoff does not drain into **manure storage** or animal confinement areas. In such cases, gravel **splash pads**, vegetation, or **subsurface drains** along building foundations may be sufficient to control runoff and prevent erosion.

### Downspouts

Fasten **downspouts** securely at the top and bottom, with intermediate supports if required. Protect downspouts from damage by animals and equipment.

### Splash pads

When downspouts empty onto the ground, surface elbows should direct water away from the building and empty onto **splash pads** or other **energy dissipaters** to prevent erosion.

## Runoff Diversion

Diverting “clean” water around horse keeping areas reduces the creation of “polluted” water that must be managed. ***Diversions, berms,*** and curbs can be used to divert “clean” stormwater runoff around buildings, high-use areas, and ***manure storage areas.***

### Diversions

A ***diversion*** is a channel or ***ditch***, constructed across the slope, to divert excess water from one area to another. Selecting the proper type and size will depend on site-specific factors such as slope, soil type, and volume of water to be managed. For steeper grades or large flows, the ***diversion*** may need to be lined with rock or similar erosion protection.



A ***diversion*** will direct “clean” stormwater runoff around buildings, high-use areas, and manure storage areas. Slope, soil type, and volume of water will determine the specific diversion size, type and design.

### Berms

A ***berm*** is formed by mounding earth materials, similar to building a curb, to redirect water from one location to another. In situations with limited space or where other uses prohibit the use of an open ***diversion ditch***, a compacted earthen ***berm*** can divert runoff into an ***underground pipeline***. Concrete or asphalt curbs, kickboards, and railroad ties can also be used to divert stormwater runoff.

In some cases, a ***grassed or lined waterway*** can serve as both the ***diversion*** and the means of conveyance used to transport water to the final discharge area such as a ***filter strip*** or ***sediment pond***.

## Runoff Conveyance

Once runoff has been collected or diverted, it must often be routed, or conveyed, to the discharge area. To determine the proper type and size of a conveyance system, consider site specific and local factors including slope, soil type, and the volume of water to be managed. For some situations, it may be necessary to link several types of conveyance systems together in a series. For example, ***underground pipelines*** could carry water from a ***downspout*** to a ***grassed waterway*** that then empties into a creek. Be certain that collected and conveyed runoff is “clean” before finally emptying to a creek.

Erosion by the conveyance of water in channels is a prime concern. Large volumes of water with high velocities may require that waterways be lined to prevent erosion.

Conveyance structures include *grassed waterways*, *lined waterways*, *drop inlets*, and *underground pipelines*. These are described below.



**Grassed waterways** convey concentrated runoff along gradual slopes. They require professional calculations of water volume and velocity. Grass must be established before the waterway is ready to carry winter runoff. Upkeep is needed to maintain capacity, grass cover, and the outlet (or end point).



An **erosion control blanket** can help stabilize the channel until the grass is fully established. It can also be used as an immediate repair for grassed areas that are damaged by horses, machinery, or erosion.

### Grassed waterway

A grassed waterway is a wide, shallow, flat-bottomed channel or ditch, with gentle side slopes that conveys concentrated runoff along gradual slopes without causing erosion or flooding.

**Grassed waterways** generally work well with water velocities of 5 feet per second (fps). For channels with poor grass cover and little maintenance, the velocity should not exceed 3 - 5 fps. Water velocities over 5 cfs need a **lined waterway**. A professional should calculate the volume and velocity for site-specific conditions. During construction, stockpile topsoil and re-spread where necessary to provide a seedbed for the grass. Excess earth should be spread where it will not interfere with flow into the waterway.

Sufficient vegetation must be established in the waterway before it carries runoff from heavy winter rains. Seedbed preparation, time of **seeding**, seeding mixture and rate, and fertilizer requirements are site-specific. Special protection such as a biodegradable **erosion control blanket** may be required to help stabilize the channel until vegetation is fully established. (Use heavy duty blankets in situations with flowing water. Avoid using blankets with plastic netting so that birds and small animals do not become trapped.) Supplemental irrigation will help establish grass sooner.

Maintenance is required to ensure waterway capacity, vegetative cover, and the outlet.

Vegetation damaged by horses, machinery, or erosion must be repaired promptly. Give special attention to outlets and points where concentrated flow enters the **grassed waterway**. Maintenance tasks should include checking for sediment accumulation and erosion, removing debris, and making necessary repairs.

### Lined waterways

These have erosion-resistant linings of concrete, rock riprap, grouted rock riprap, mortared flagstone, or other permanent material that extend up the side slopes of the channel above the anticipated flow. The bare soil on both sides of the waterway above the permanent lining should be vegetated or otherwise protected. **Lined waterways** should be used if concentrated runoff requires a lining to control erosion (flows greater than five cfs); steep grades, prolonged base flow, or seepage may cause erosion; human or animal use of the area precludes using a **grassed waterway**; high-value property or adjacent facilities warrant the extra cost to contain runoff in a limited space; or if soils are highly erosive.



*In areas with flows greater than 5 cubic feet per second, steep grades, prolonged flows, highly erosive soils, or other special conditions, a **lined waterway** should be used. Concrete, rock riprap, grouted rock riprap, mortared flagstone, or other permanent material will line the channel.*

### Drop inlets

**Drop inlets** can be used to transfer channel flow into an **underground pipeline**. Elevating the inlet above the channel bottom will cause water to pool up in the trap before entering the inlet. This ponding of water allows heavier suspended particles to settle. Inlets must be regularly checked and kept free of debris during and after storms.

### Sediment basin

**Sediment basins** can be incorporated into the outlet design. Regular clean out of sediment must be performed. Other maintenance includes clearing debris and inspection during and after storms. Screens or **trash racks** may be required immediately upstream of the basin to stop debris before it can clog the inlet. Without maintenance, inlets and trash racks cease to function and structures can be undermined by water and cause erosion problems that may be worse than the original situation.



*Be sure **underground pipeline** is properly installed by compacting soil around the pipe, and installing cutoff collars, if needed, so water does not seep along the pipeline and wash away soil leaving an exposed pipeline susceptible to damage. Also be sure pipes are properly sized to handle flows.*

### Underground pipelines

These are an effective way to convey water when space is limited and surface channels are not practical. As with all drainage structures, calculation of anticipated flow and proper sizing are crucial.



**Rock energy dissipaters** reduce the velocity and energy of concentrated storm flows. They are used at the outlets of pipelines, culverts, or other conveyance structures. Calculate the size of rock needed and place rock carefully. Make sure dissipaters are in place before the rainy season.

## Discharge Area

“Clean” water can be discharged into another conveyance structure, a seasonal drainage, creek, *constructed wetland*, or directed to a *filter strip* or pasture. Be sure to use *energy dissipaters* to control potential erosion.

## Energy dissipaters

These are placed at channel outlets to reduce the velocity and energy of concentrated storm flows, prevent scour, and minimize downstream erosion. They may be needed at the outlets of *underground pipelines*, *culverts*, or where *lined waterways* discharge to unlined conveyances, e.g., a rock channel discharges into a *grassed waterway*.

Rock is a common *energy dissipater*. The type and size of an *energy dissipater* depends on local factors. Rock should be carefully and tightly placed over a filter fabric. Loose rock can wash away during high flows. Rock should be angular and large enough to withstand heavy flows.

## 4.3 Measures to Manage “Polluted” Water

“Polluted” water must be managed so that it does not reach creeks or leach into ground water. Conservation measures that can help utilize nutrients, or store waste water until it can be utilized are:

- Filter Strip
- Riparian Buffer
- Willow sprigging
- Constructed Wetland
- Waste Pond

### Filter Strip

A *filter strip* is an area of grass designed specifically to trap sediment, horse manure and other pollutants before they enter surface water, such as a creek or a pond. Actively growing grass will use the nutrients in runoff that comes from a manured area. *Filter strips* can be developed downslope of high-use areas to trap sediment and manure that washes off of these areas.

**Filter strips** should be designed and maintained to transport a thin “sheet” of runoff slowly through the vegetation. A gentle slope covered with lush vegetation reduces flow. Thick, sod-forming grass works best to trap sediment. The slow movement of runoff through the vegetation provides an opportunity for sediments to be trapped by vegetation. Nutrients and other pollutants are utilized or degraded through microbial action in the soil.

Obtain professional assistance to determine the size of the strip necessary to treat the water, based on the suitability of the existing soil type, slope, rainfall data, and results of percolation tests. The width of the vegetative **filter strip** will be site-specific and depends upon slope, runoff volume, rate of infiltration, pollutants of concern, amount of pollutants, sediment size, and vegetation height and density. A flow-path length of 20 feet is minimal for most sediment removal. An additional 15 to 80 feet is needed to treat nutrients.<sup>12</sup> The key concept is to move water slowly through the vegetation. Too rapid drainage will not allow vegetation to utilize nutrients in the runoff or infiltration to reduce pollutants.

It is important to maintain **filter strips**. Maintenance activities should include mowing **filter strip** grasses to encourage dense, upright vegetative growth; excluding horses and vehicular traffic to keep the land smooth for sheet flow and to avoid soil compaction; inspecting **filter strips** after storms, and taking other measures to promote “sheet flow” in the **filter strip**; and reseed when necessary.

See Section 5.2 of the Resources Directory for **seeding** and **mulch** specifications.

## Riparian Buffer

Riparian areas are located immediately adjacent to creeks. Unlike **filter strips** that are primarily grassed areas, **riparian buffers** have a dense mix of grasses, trees, and shrubs. These buffers enhance water quality, provide wildlife habitat, and have aesthetic value. Benefits of a buffer include:

- Dense grasses to trap sediment, promote infiltration, and slow runoff flows.



Use grass **filter strips** downslope of high-use areas such as turnouts, arenas, and horse wash areas to trap sediment and manure that washes off. Filter strips should be at least 20 feet wide and require annual monitoring and maintenance.



This **filter strip** is designed and maintained to transport a thin “sheet” of runoff slowly through vegetation. A gentle slope covered with lush vegetation achieves slow flow. Thick, sod-forming grass works best to trap sediment.

<sup>12</sup> USDA, NRCS - California, Field Office Technical Guide, Filter Strip. July 2000.



A **riparian buffer** has a mix of trees, shrubs and grasses and is located adjacent to and upslope from creeks. The riparian buffer reduces excess amounts of sediment, organic material, nutrients, pesticides and other pollutants in surface runoff and reduces excess nutrients and other chemicals in shallow ground water flow. The buffer also creates riparian habitat and corridors for wildlife, as well as shade to lower water temperature to improve habitat for fish and other aquatic organisms.

- Grasses, shrubs, and trees to utilize excess nutrients.
- Trees and shrubs help stabilize streambanks and create a shade canopy to cool water for aquatic life, reduce floodwater velocity and erosive power, and trap debris during floods. A diverse mix of grasses, shrubs, and trees that provide wildlife habitat for a wide range of mammals, reptiles, amphibians, birds, and invertebrates species. Connected stretches of buffers become wildlife corridors.
- A visual screen that also acts as a windbreak and helps capture dust.

Many riparian areas in the San Francisco Bay Area have been cleared of vegetation, or creek channels have been lined with concrete. This section outlines steps to enhance your existing *riparian buffer* or to restore a degraded buffer.

- 1. Evaluate the existing riparian area to identify any repairs** (such as an eroding streambank or bare areas that need replanting) and management constraints (such as the need for livestock control *fencing*, *stream crossing*, and/or an alternative water source).
- 2. Determine the minimum buffer width.** The width may vary a great deal depending on site conditions, vegetation, soil type, and landowner objectives. Generally, the wider the buffer, the greater the overall level of benefit. Although a narrow buffer provides more benefits than no buffer at all, wildlife habitat benefits will be reduced. Narrow buffers require careful consideration of slope and selection of vegetation to insure effectiveness. Greater width may be required for shrub and tree vegetation, on steeper slopes, or where sediment loads are particularly high. Some counties require setbacks from creeks.
- 3. Consider slope when determining infiltration benefits.** Buffers with a gentle slope and even surface will allow water to flow slowly through the buffer in a thin layer as “sheet flow.” These buffers will have more infiltration than buffers in steeper areas where water flow is concentrated or even flows in tiny channels (rills). Riparian areas should not be graded to change the slope. Grading within riparian areas can require a permit from the California Department of Fish and Game and other agencies.

**4. Select appropriate vegetation.** The mix of grasses, forbs, shrubs, and trees will be dependent upon the benefits you want. Select native plant species to benefit wildlife. If flood control is a prime concern, plant a greater proportion of the buffer width to flood-tolerant trees and shrubs. If supplemental water is not available, choose plants that can survive the first few years without irrigation (such as grasses and willows). The following table lists vegetation types and benefits.

**Table 4: Vegetation Type and Riparian Buffer Benefits<sup>13</sup>**

<b>Benefit</b>	<b>Grasses</b>	<b>Shrubs</b>	<b>Trees</b>
Filter sediment	High	Low	Low
Utilize nutrients, microbes bound with sediment	High	Low	Low
Utilize nutrients, soluble (in water)	Medium	Low	High
Stabilize bank erosion	Low	High	High
Flood protection	Low	Medium	High
Habitat (range/pasture/wildlife)	High	Medium	Low
Visual diversity	Low	Medium	High

<sup>13</sup> From "How to Design a Riparian Buffer for Agricultural Land," *AgroForestry Notes* 4, 1997. M. Dosskey, D. Schultz, T. Isenhart. Iowa State University Department of Forestry.

Common native riparian trees in the San Francisco Bay Area can include willows, alders, box elder, California bay, Oregon ash, valley oak, coast live oak, black oak, Oregon oak, coast redwood, California buckeye, and big leaf maple. Common riparian shrubs can include California blackberry, elderberry, California hazelnut, coffeeberry, dogwood, ninebark, salmonberry, snowberry, spicebush, thimbleberry, twinberry, toyon, western azalea, and willow. Check with your local Resource Conservation District or native plant nursery for specific species that will thrive in your area.

**5. Develop an installation and maintenance plan.** An installation and maintenance plan is necessary to obtain successful buffer establishment and long-term benefits.

### Installation Tips

- Use local knowledge to select the best plant species and spacing for each situation. Emphasize native species yielding quick establishment and good growth on the site. Contact your local RCD, UC Cooperative Extension, local chapter of the California Native Plant Society, or a seed supplier for planting ideas. See Section 5.1 of the Resources Directory for contact information.
- Install livestock control *fencing* before planting. Fencing should be set back from the creek to allow the creek to meander naturally.
- Conduct planting and repair work at the appropriate time of year. Grading should occur in the dry season and usually must be completed by October 15. *Seeding* and *mulching* should occur by mid-October, *willow sprigging* should

take place in November or early December when the plants are dormant, and container grown trees and shrubs should be planted between November and February. Planting should occur after the first storms and before soil is saturated during the winter.

- Irrigate and *mulch* to enhance tree and shrub survival. A temporary drip irrigation system (for the critical first three years) will help ensure plant success. Thoroughly composted manure makes good mulch.
- Incorporate existing trees and perennial vegetation into the buffer. Be sure not to plant inside the drip line of mature trees.
- Consider removing non-native exotic species that can crowd out existing and new native vegetation. Invasive non-native species to watch include giant reed (*Arundo donax*); periwinkle (*Vinca major*); Scotch, French, and Spanish broom; Himalayan blackberry; tree-of-heaven; bamboo; pampas grass; German and English ivy; acacia; and ice plant.
- Obtain required permits for grading and certain repairs. See Sections 5.4 and 5.5 of the Resources Directory for more information.

### Maintenance Tips

- Control weeds by mowing and *mulching* until trees and shrubs are large enough to compete on their own. This is typically required for the first two to three years after planting.
- Protect tree and shrub plantings from wildlife, such as deer, rabbits and mice, with short collars of plastic protective tubing, “gopher baskets,” wire cages, or similar forms of protection.
- Check the irrigation system periodically to make sure it is functioning properly.
- Control livestock *grazing* of the buffer area. Once the vegetation is established, you may want to initiate a limited *grazing* regime in the buffer. The best time to graze is in the spring when the rains have subsided and the ground is firm.
- Replant areas where plants do not “take.”
- Periodically mow grasses to help maintain vigorous plant growth and promote additional nutrient uptake.
- Do not apply fertilizers or manure, and limit pesticides and herbicides in the buffer zone.

**6. Develop alternative water sources for horses.** If horses are excluded from the creek, they will need another source of drinking water. Horses consume approximately 8-12 gallons of water per day. Alternative water options include *spring development* with buried *pipelines*, and *troughs*, or extending existing water systems. You may also need a *storage tank*.

## Willow Sprigging

Willows are an effective and inexpensive way to armor creek banks and gullies and to provide important wildlife habitat. Prune and shape willows to keep them from invading the creek channel and potentially causing flooding and bank erosion problems. Allow trees to grow tall to help shade out the lower growing vegetation.

Revegetating with willows is the easiest way to establish woody vegetation on a denuded creek bank. Adequate year-round water and sun are keys for willow establishment and survival. Even if a creek doesn't have year-round, above-ground flows, the ground water may be near enough to the surface to support willows.

Willows can be planted from dormant cuttings or "sprigs" following these steps:

1. Cut willows in the fall as soon as the leaves have dropped, and the ground is soft and wet. It is critical to plant willows as early as possible (November through January, or earlier with irrigation). This gives them a chance to develop good root systems before they sprout leaves in the spring. Planting too late is the most common cause of failure.
2. Willow cuttings should be at least 3/4-inch in diameter. Bigger is better. Cuttings should be at least 14 inches long.
3. Plant dormant cuttings by pushing the cut end into soft soil, or make a hole with a sharp stick or pick. If you make a hole, be sure to compress soil tightly around the cuttings. They may need to be pounded in with a hammer. To give plenty of area for root growth, bury at least two-thirds of the length of the cutting. Angle sprigs slightly downstream to prevent them from being undermined by storm flows.
4. Plant willows low enough on the bank to ensure adequate soil moisture during the summer. Even if streams or gullies have year-round water, willows that are planted too high are likely to dry out and die. Cuttings should not need water if they are planted in an appropriate area.

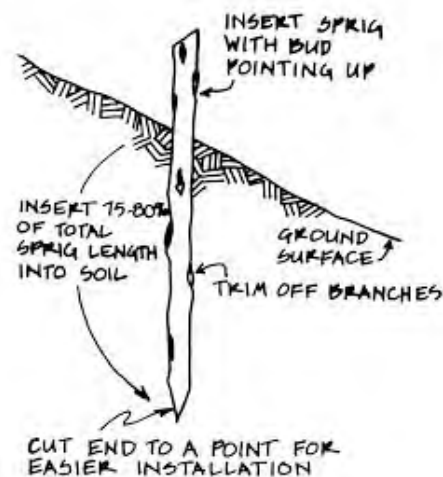

*Install willow cuttings to armor creek banks and gullies in areas with plenty of sunlight. Cuttings should be 3/4 inch in diameter and planted at least two-thirds into the ground. Plant cuttings low enough on the bank where they will receive adequate moisture in the summer. Angle cuttings downstream so they will "go with the flow" of water. Timing is crucial—make sure cuttings are planted from November through January.*

### More on Willow Planting

How to Plant Willows ... for Riparian Rehabilitation, is available at:

<http://plant-materials.nrcs.usda.gov/technical/publications/riparian.html>

Under Technical Notes, Select: Technical Note 23: How to plant willows and cottonwoods for riparian rehabilitation.

## Constructed Wetland

*Constructed wetlands* “treat” waste from confined animal operations, surface runoff, and manure storage area leachate. Approximately two feet deep, these wetlands have water-loving plants that are capable of removing large amounts of nutrients from the water. Retention time and release rate will depend upon the size of the wetland and period needed to extract the nutrients.

*Constructed wetlands* must be professionally designed to handle the volume of waste or stormwater runoff, particularly the “first flush” that contains a high concentration of pollutants. Careful construction is required to ensure that the ground is properly prepared and permits may be needed.

## Waste Pond

Horse manure is best handled as a solid.<sup>14</sup> If a *waste pond* is required by local regulation, then this overview of *waste ponds* can help in the planning stages. A waste storage pond collects runoff of polluted water and gives the manager control over the scheduling and timing of waste distribution over the land. Adequate storage gives flexibility to schedule *manure application* when spreading operations do not interfere with other necessary tasks, when weather and field conditions are suitable, and when pasture or crops can best use the nutrients in the waste.



**Waste ponds** can be used to store polluted runoff. Waste from the pond is typically irrigated or spread on land. Pond maintenance will ensure proper functioning. A professional can assist with pond sizing. Trees and shrubs have been planted around this waste pond to screen it from the road.

Pond location is important. It should be convenient to the operation with suitable soils that when properly compacted, will be impervious to seepage into the ground water. Various materials are available for *pond lining*, such as compacted clay or geotextile fabric.

Utilization of the contents in the *waste pond* is commonly done by land application. This includes selecting the fields, scheduling *manure application*, designing the distribution system, and selecting necessary equipment. It also includes determining application rates and volumes, value of recycled products, and installation and management costs associated with the utilization process.

Pond sizing needs to be done by a professional to take into consideration the required storage volume, storage period, and the type, estimated size, location, and installation cost of the pond. Permits are usually required for *waste pond* construction; contact local and state officials (see Sections 5.4 and 5.5 of the Resources Directory). Maintenance and protection of the pond are needed to ensure its longevity.

<sup>14</sup> *Feedlots Preliminary Data Summary*. December 31, 1998. EPA. Available at <[www.epa.gov/ostwater/guide/feedlots/execsumm.pdf](http://www.epa.gov/ostwater/guide/feedlots/execsumm.pdf)>



## Chapter 5

# Resources Directory

This Resources Directory provides technical background and contact information. Topics include:

- **Section 5.1:** Technical Assistance
- **Section 5.2:** Seeding Recommendations for Horse Facilities in the San Francisco Bay Area
- **Section 5.3:** Winterization Checklist
- **Section 5.4:** Regulations and Permits
- **Section 5.5:** Threatened and Endangered Species
- **Section 5.6:** Photographic Monitoring
- **Section 5.7:** Water Quality Monitoring
- **Section 5.8:** Guidelines for Managing Residual Dry Matter
- **Section 5.9:** Alternatives to Pesticides
- **Section 5.10:** Improving Songbird Habitat on your Horse Ranch
- **Section 5.11:** Helpful Publications and Resources

## 5.1 Technical Assistance

Technical assistance is available from the following organizations. Advice is offered as a free service from the RCDs, NRCS, and UC Cooperative Extension.

### Resource Conservation Districts

Resource Conservation Districts (RCDs) have been helping landowners to apply conservation measures on Bay Area farms and ranches since the 1930s and can help equine facility landowners in a similar way. RCDs provide information, technical assistance, and implementation of natural resource conservation projects. RCDs work in partnership with the USDA Natural Resources Conservation Service. They are non-regulatory special districts governed by a local volunteer board of directors.

Check with your local RCD to learn about specific services provided in your area. RCDs offer workshops and courses for landowners, as well as one-on-one meetings. In the San Francisco Bay Area, nine RCDs are also part of the Council of Bay Area RCDs and work together on shared natural resource issues. The following RCDs participated in the Equine Facilities Assistance Program. To find other RCDs, visit <http://www.carcd.org/>

#### **Marin County RCD**

P.O. Box 1146  
Point Reyes Station, CA 94956  
Phone: (415) 663-1170  
Fax: (415) 663-0421  
<http://www.sonomamarinrcds.org/>

#### **Alameda County RCD**

1996 Holmes Street  
Livermore, CA 94550  
Phone: (925) 371-0154  
Fax: (925) 371-0155  
<http://www.baysavers.org/>

#### **Southern Sonoma County RCD**

1301 Redwood Way, Suite 170  
Petaluma, CA 94954  
Phone: (707) 794-1242, ext 3  
Fax: (707) 794-7902  
<http://www.sonomamarinrcds.org/>

#### **San Mateo County RCD**

625 Miramontes Street, Suite 206  
Half Moon Bay, CA 94019  
Phone: (650) 726-4660  
Fax: (650) 726-0494

#### **Contra Costa RCD**

5552 Clayton Road  
Concord, CA 94521  
Phone: (925) 672-6522  
Fax: (925) 672-8064

## **USDA Natural Resources Conservation Service**

The Natural Resources Conservation Service (NRCS) is an agency of the US Department of Agriculture that provides technical assistance to land users and communities. The NRCS, in cooperation with Resource Conservation Districts, provides free technical information and assistance upon request that address concerns about natural resources such as animal waste management, rangeland, cropland, and watershed management. NRCS also provides free soil survey information, as well as information about local cost-share programs. NRCS offices for the counties participating in the Equine Facilities Assistance Program are listed below. To find offices in other areas, visit <http://www.ca.nrcs.usda.gov/>

### **Alameda County**

3585 Greenville Road, Suite 2  
Livermore, CA 94550-6707  
Phone: (925) 371-0154  
FAX: (925) 371-0155

### **Marin and Sonoma Counties**

1301 Redwood Way, Suite 170  
Petaluma, CA 94954  
Phone: (707) 794-1242, ext 3  
FAX: (707) 794-7902

### **Contra Costa County**

5552 Clayton Road  
Concord, CA 94521  
Phone: (925) 672-4577, ext 3  
FAX: (925) 672-8064

## University of California Cooperative Extension

The University of California Cooperative Extension (UCCE) is part of a state-wide system of specialists and county-based farm advisors who work to bring the University's research-based information to Californians. UCCE's many teaching tools include workshops, demonstrations, field days, meetings, conferences, video programs, newsletters, and manuals. Several publications relate directly to horse keeping and are available from University of California Agriculture and Natural Resources Communication Services, (800) 994-8849. Contact your local office for information about workshops and assistance. Listed below are counties participating in the Equine Facilities Assistance Program. To find a local office in other areas, visit <http://vcnr.org/ce.cfm>

### **Marin County Cooperative Extension**

1682 Novato Boulevard, Suite 150B  
Novato, CA 94947  
Phone: (415) 499-4204  
Fax: (415) 499-4209  
Email: [cemarin@ucdavis.edu](mailto:cemarin@ucdavis.edu)  
<http://cemarin.ucdavis.edu>

### **Alameda County Cooperative Extension**

1131 Harbor Bay Parkway, Suite 131  
Alameda, CA 94502  
Phone: (510) 567-6812  
Fax: (510) 567-6813  
Email: [cealameda@ucdavis.edu](mailto:cealameda@ucdavis.edu)  
<http://cealameda.ucdavis.edu>

### **Sonoma County Cooperative Extension**

133 Aviation Blvd, Suite 109  
Santa Rosa, CA 95403  
Phone: (707) 565-2621  
Fax: (707) 565-2623  
Email: [cesonoma@ucdavis.edu](mailto:cesonoma@ucdavis.edu)  
<http://cesonoma.ucdavis.edu/>

### **San Mateo County Cooperative Extension**

625 Miramontes Street, Suite 200  
Half Moon Bay, CA 94019  
Phone: (650) 726-9059  
Email: [cesanmateo@ucdavis.edu](mailto:cesanmateo@ucdavis.edu)  
<http://cesanmateo.ucdavis.edu/>

### **Contra Costa County**

#### **Cooperative Extension**

75 Santa Barbara Road, 2nd Floor  
Pleasant Hill, CA 94523-4488  
Phone: (925) 646-6540  
Email: [cecontracosta@ucdavis.edu](mailto:cecontracosta@ucdavis.edu)  
<http://cecontracosta.ucdavis.edu/>

## Private Consultants

Private consultants, such as engineers, construction contractors, and certified erosion control specialists, can provide a variety of services related to water quality management including planning, design, and construction of conservation measures. Lists of local consultants may be available from the local RCD or NRCS office.

## Seed Suppliers and Native Plant Information

Some seed supply businesses and nurseries have agronomists and other specialists available to help you select the best seeds to suit your local conditions and needs. For native plant information try the following resources or visit the California Native Plant Society at <http://www.cnps.org/>

Harmony Farm Supply  
3244 Gravenstein Highway North  
Sebastopol, CA 95472  
Phone: (707) 823-9125  
Fax: (707) 823-1734

Elkhorn Native Plant Nursery  
Struve Road (P.O. Box 270)  
Moss Landing, CA 95039  
Phone: (831) 763-1207  
Fax: (831) 763-1659

LeBallister's Seed  
1250 Sebastopol Road  
Santa Rosa, CA 95407  
Phone: (707) 526-6733  
Fax: (707) 542-9740

Clyde Robin Seed Company  
P.O. Box 2366  
Castro Valley, CA 94546  
Phone: (510) 785-0425  
Fax: (510) 785-6463

Native Revival Nursery  
8022 Soquel Drive  
Aptos, CA 95003  
Phone: (831) 684-1811

S&S Seeds  
P.O. Box 1275  
Carpinteria, CA 93014-1275  
Phone (805) 684-0436  
Fax: (805) 684-2798

Central Coast Wilds  
114 Liberty St.  
Santa Cruz, CA 95060  
Phone (831) 459-0656  
Fax (831) 457-1606

Pacific Coast Seed  
6144-A Industrial Way  
Livermore, CA 94550  
Phone: (925) 373-4417  
Fax: (925) 373-6855

Larner Seeds  
235 Grove St./P.O. Box 407  
Bollinas, CA 94924  
Phone: (415) 868-9407  
Fax: (415) 868-2592

## 5.2 Seeding Recommendations for Horse Facilities in the San Francisco Bay Area

### Conservation Measures

You have evaluated your horse facility and come to the conclusion that excessive soil erosion is coming from a **pasture** or high-use area (**critical area**), such as paddocks, turn-out areas, roads, or a parking lot. Perhaps you need to convey water around a barn through a **grassed waterway**. Or maybe rainwater flows through a manured area, and you want to use a **filter strip** to reduce pollutants in the polluted water. The vegetation planted for these conservation practices will reduce soil erosion, increase infiltration, percolation, and ground water recharge.

These seeding recommendation mixtures are for general dryland (non-irrigated) purposes. Specific recommendations will vary based on site evaluation that would take into account rainfall, length of growing season, soils, etc. Since the San Francisco Bay Area has many micro-climates, your local USDA Natural Resources Conservation Service, UC Cooperative Extension Farm Advisor, or local seed supplier can help with specific suggestions. Different grass species are suitable for different purposes. Perennial grasses are deeper rooted and certain species are sod-forming (rather than bunchgrasses), which protects the soil from excessive erosion. Annual grasses provide a quick cover and reseed themselves each year.

#### Filter Strip

A grass filter strip is designed to treat runoff situated between high-use areas and environmentally sensitive areas, such as a creek, seasonal drainage or pond. The filter strip will reduce sediment, sediment adsorbed pollutant loading in runoff, and dissolved contaminant loading in runoff. Also, a filter strip will restore, create or enhance habitat for wildlife and beneficial insects.

A filter strip must be designed so overland flow (runoff) entering it must be primarily sheet flow. Concentrated flow must be dispersed into sheet flow, before entering the filter strip. The minimum width is 20 feet to reduce sediment. Additionally, to reduce dissolved pollutants in runoff, the minimum width is 30 feet. Local site criteria may require filter strip widths of up to 100 feet. (*Reference: USDA NRCS Field Office Technical Guide, Filter Strip.*)

#### Grassed Waterway

Imagine a gentle flat-bottomed ditch, fully clothed in grass, with gentle side slopes. This simple design is a grassed waterway—a designed channel that is mechanically shaped or graded with a bulldozer, and seeded with grass for the stable conveyance of runoff. The grassed waterway will convey runoff without causing erosion or flooding. As with all engineered conveyances, the grassed waterway must be designed to withstand the velocity of water anticipated. The site must be assessed to see if the waterway needs to be lined for higher water velocities with erosion control matting, rock or concrete. Grassed waterways

## Seeding Recommendations

Note: Species in bold are native to California

Seed Mixture	Plant Characteristics	Lbs/Acre	Filter Strip	Grassed Waterway	Critical Area	Pasture
1. Berber orchardgrass <sup>1</sup>	Perennial grass	16	X	X		
2. <b>Creeping wildrye</b> <sup>1,2</sup>	Perennial grass	30 <sup>3</sup>	X	X		
3. 'Blando' brome	Annual grass	18	X	X	X	
'Zorro' annual fescue	Annual grass	10				
Rose clover <sup>4</sup>	Annual legume	9				
<b>California poppy</b> <sup>5</sup>	Annual wildflower	1				
<b>Arroyo lupine</b> <sup>5,6,7</sup>	Annual wildflower	1				
Crimson clover <sup>4</sup>	Annual legume	1				
4. <b>California brome</b> <sup>1</sup>	Perennial grass	25	X		X	
<b>Blue wildrye</b> <sup>1</sup>	Perennial grass	18				
<b>California poppy</b> <sup>5</sup>	Annual wildflower	1				
<b>Arroyo lupine</b> <sup>5,6,7</sup>	Annual wildflower	1				
5. Blando brome	Annual grass	25			X	
Annual ryegrass	Annual grass	24				
6. 'Berber' orchardgrass <sup>1</sup>	Perennial grass	4				X
Tetraploid perennial ryegrass <sup>1</sup>	Perennial grass	6				
Subclover <sup>4,7</sup>	Annual legume	6				
Rose clover <sup>4</sup>	Annual legume	4				
7. 'Blando' brome	Annual grass	6				X
Rose clover <sup>4</sup>	Annual legume	6				
Subclover <sup>4,8</sup>	Annual legume	6				

<sup>1</sup> Mulch must be used to provide initial erosion control when establishing perennials.  
<sup>2</sup> Also known as beardless wildrye.  
<sup>3</sup> Or use plugs at 1 foot x 1 foot spacing.  
<sup>4</sup> Also see "legume inoculation" section below.  
<sup>5</sup> Optional, use for color.  
<sup>6</sup> *Lupinus succulentus*, also known as hollowleaf annual lupine.  
<sup>7</sup> Lupine may be toxic to horses. Use only where horses do not graze.  
<sup>8</sup> Use locally adapted varieties recommended by UC Cooperative Extension.

perform most dependably in areas where dense stands of sod-forming grass will permit anticipated water velocities.

The most critical time in successfully installing a grassed waterway is when vegetation is being established. Special protection such as mulch or an erosion control blanket is warranted at this critical period. Supplemental irrigation is optimal. The vegetation should be well established before large flows are permitted in the channel.

### Critical Area

Critical erosion areas such as road cuts and fills, roadbeds, and gullied areas need to be stabilized to reduce damage from runoff. Seeding is used where vegetation is difficult to establish.

Plants should have the ability to provide adequate ground cover, canopy cover and root mass for erosion protection. High seeding rates are needed to insure adequate vegetative cover because these sites have been severely eroded or disturbed, have low fertility, and few resident seeds.

### **Pasture**

It is time to reseed a pasture when horses excessively use one area of pasture, or selectively graze desirable plants and leave the less desired plants. Nearly all pastures have areas where horses concentrate such as around water and feed areas. Under continuous use, these are always overgrazed.

## **Installation Criteria**

**Timing:** Plant before the rainy season, October 15<sup>th</sup> of the year.

**Seeding rate:** Seeding rates are for 100% Pure Live Seed (PLS), and are broadcast (by hand or broadcast seeder) rates. Seed bag “tags” tell the percent purity for PLS and germination rate. If seed bag tag states less than 100% PLS, increase the amount of seed in proportion to the percentage needed (germination x purity). Time since the date of seed test on the tag should not exceed 9 months.

**Seedbed preparation:** The area to be planted must be weed free and have a firm seedbed which has been previously roughened by disking, harrowing, or otherwise worked to a depth of 2 to 4 inches, except when planting no-till. No implement should be used that would create an excessive amount of downward movement of soil on sloping areas. Weeds and other debris that would interfere with seeding or maintenance should be removed.

**Legume Inoculation:** All legumes (clovers) should be “inoculated” before planting with a pure culture of nitrogen-fixing bacteria and prepared specifically for that plant species. This is done immediately prior to planting. The seeding rate does not include the weight of inoculant and seed coating.

**Why:** All legumes, including clover, have the ability (in cooperation with legume bacteria) to draw nitrogen from the air and store it in the small nodules that form on the roots. Studies have shown an increase in forage production and nitrogen fixation when seed is properly inoculated. On poorer soils, the clover seed may be a complete failure if not properly inoculated. The bacteria are helpful to young plants as roots begin to develop, increasing their chance to grow successfully.

**How:** Put seed on canvas, in tub or other container. Mix the inoculating culture with the seed and stir until the seed is well covered. Mix with grass seed selected. Prevent from drying out by sun or wind. Plant immediately.

**Mulch:** A straw mulch cover should be uniformly distributed over the seeded area within 48 hours following the seeding. Straw mulch should be applied at a rate of

two tons per acre (or one 74-pound bale per 800 square feet, at a uniform depth of 2 to 3 inches). Straw is the preferred mulch and needs to be anchored in place. Hand punching with a shovel or a square-end spade can work for small areas, whereby straw stands perpendicular to the slope and is embedded at least 4 inches into the slope, and punched about 12 inches apart. For larger areas, anchoring with rollers, crimpers, or disks can be used on slopes up to 3-to-1. Use of rice straw will minimize weed seeds, since the type of weeds that grow in the aquatic environment with rice will not survive on dry land sites. Use of wheat straw will result in less volunteer grain compared to barley straw. When using straw grown in the same county, use clean straw to minimize the spread of noxious weeds. Bales of native grass with seed are also a good option.

**Irrigation:** A sprinkler system is optimal for establishment and water should be applied during the establishment period. Maintain adequate moisture in the upper six inches of soil during the first four weeks, and then in the upper 12 inches thereafter until the rainy season.

**Maintenance:** Mowing should be performed for control of noxious weeds or for a firebreak. Periodic mowing can be performed to reduce rank growth and maintain desired species populations. Herbicides should only be used to control noxious weed species.

Limit traffic and do not use as a roadway. Limit livestock use. For filter strips and grassed waterways, eradicate or remove all burrowing rodents and immediately repair any damage caused by their activity.

*Written by Lisa Woo Shanks and Dennis Moore  
USDA Natural Resources Conservation Service*

## 5.3 Winterization Checklist

Preparing for the rainy season while the weather is still nice can save a lot of time in the long run. Take time to inspect your facility before the rains start. Write and post a “winterization” checklist in your barn to help set priorities, organize work, and take action. It is important to check many of these areas throughout the winter, particularly during and after major storms. A sample list below covers management strategies discussed in this guide.

### Buildings

- Inspect, repair, and remove debris from *gutters* and *downspouts*. Make sure *gutters*, *downspouts* and pipelines are connected.
- Clear debris from *diversions*, *pipe inlets*, grates, *culverts*, and *trash racks*.
- Make sure *energy dissipaters* (such as rock) are placed at outlets.

### High-Use Areas

- Replenish footing in high-use areas.
- Make sure kickboards are in place to help keep footing material in place.
- Clear debris from *diversions* and other drainage structures.

### Manure Management

- Scrupulously clean out *paddocks*.
- Remove all horse waste from *manure storage areas* by the fall.
- Cover *manure storage areas* and provide runoff controls. Make sure “clean” water is diverted from manured areas.
- Apply manure to pastures in early fall, and in spring when grasses are actively growing. Do not spread manure near creeks.

### Pasture Management and Filter Strips

- Re-seed pastures and grass *filter strips* by October 15, if needed. Remove weeds regularly.
- Mow, maintain and/or reseed grass *filter strips* downslope of high-use areas.
- In the fall, check *Residual Dry Matter* (RDM) levels in pastures. (See Section 5.8 of the Resources Directory.)

### Roads and Trails

- Clean out *ditches*, *culvert* inlets, and *trash racks*.
- Make sure *waterbars* and *energy dissipaters* are in place and functional.
- Check roads and trails after storms for any emergency repairs.
- Close roads and trails not essential for winter traffic. *Seed* and *mulch* seldom used roads or trails by October 15.

## 5.4 Regulations and Permits

### Regulation Overview

Many federal, state, and local laws pertain to water pollution and its adverse effects on drinking water supplies, recreation, and aquatic life.

The federal Water Pollution Control Act of 1972, commonly called the **Clean Water Act (CWA)**, is the nation's principal protection statute. The CWA delegates the process of setting water quality standards to the states, under the supervision of the Environmental Protection Agency. In 1987, Congress amended the Clean Water Act to include establishment of the **Non-Point Source Pollution Management Program**, requiring each state to develop a program to address this problem.

Division 7 of the California Water Code, commonly referred to as the **Porter-Cologne Water Quality Control Act**, covers water quality protection and management in California. Porter-Cologne designates the State Water Resources Control Board (SWRCB) as the state water pollution control agency. Nine Regional Water Quality Control Boards (RWQCB) establish and enforce water quality objectives to protect beneficial uses of water bodies.

Broadly protecting water quality, California's **Fish and Game Code Section 5650** declares it unlawful to deposit in, permit to pass into, or place where it can pass into water any substance or material harmful to fish, plant life, or bird life. This regulation applies as equally to horse owners as to an oil refinery.

Article 1 of the California Health and Safety Code's **California Safe Drinking Water Act** declares that every citizen of California has the right to pure and safe drinking water. In particular, Section 116995 covers pollution of drinking water by domestic animals.

Penalties for violations can include criminal misdemeanor charges, fines, abatement orders, and civil penalties, as well as the cost of legal fees, time and poor community relations. Enforcement agencies often lack the funds and personnel to search for violations, but they are required to respond to complaints. An agency's response to a complaint may include a site visit to assess the magnitude of the problem. A local or county agency may recommend and agree to specific mitigation measures. The California Department of Fish and Game and the RWQCB may recommend temporary emergency measures but refer violators to USDA Natural Resources Conservation Service or private consultants or engineers for permanent conservation measures.

## Permit Overview

Federal, state, and local water quality or other environmental laws may apply to your project to develop, expand, or renovate a horse facility, or even to control streambank erosion. If you are working in or near streams, you likely need a permit. Consultants can help you navigate the permit maze. Here is a list of agencies and their regulatory requirements that may be applicable to horse keeping facilities. Also see Section 5.5 for threatened and endangered species.

### US Army Corps of Engineers

The Corps of Engineers has regulatory authority under Section 404 of the federal Clean Water Act and Section 10 of the Rivers and Harbors Act. A 404 permit is required for work involving the placement of fill in any “waters of the United States” which includes wetlands as well as perennial, seasonal and ephemeral creeks. A Section 10 permit is required for projects affecting “navigable waters.” Corps jurisdiction extends up to the ordinary high water line for non-tidal waters and up to the high tide line (for dredge and fill) or mean high water line (for work or structures) in tidal waters. Most landowner projects should fall under the Section 404 Nationwide Permit Program. Pre- or post-project notification may be required. There is no filing fee and permit processing can take up to one year.

- Contact the San Francisco District Regulatory Branch at (415) 977-8462 or <http://www.spn.usace.army.mil/regulatory/>

### California Department of Fish and Game

The California Department of Fish and Game (DFG) requires a Stream Alteration Agreement for projects that occur in or near creeks or streambanks. This permit is necessary for any work that will divert or obstruct the natural flow of water, change the bed, channel, or bank of any stream, or use any material from a streambed. DFG will review the application for compliance with the California Environmental Quality Act (CEQA). The application is \$132 and turn-around time can be several months or longer. For permit information or assistance from DFG, contact a regional office or <http://www.dfg.ca.gov/1600>

- Central Coast Regional office is located in Yountville: (707) 944-5500
- Marine Regional Office is located in Monterey: (831) 649-2870
- A Marine Region field office is located in Menlo Park: (650) 688-6340

### Regional Water Quality Control Board

For activities requiring a permit from the US Army Corps of Engineers, the RWQCB must issue a 401 Water Quality certification to ensure that the proposed activity will not violate State water quality standards. A filing fee is required and can be \$500 or greater.

- For creeks and tributaries draining into San Francisco Bay, contact:  
San Francisco Bay Regional Water Quality Control Board  
(510) 622-2300 or <http://www.swrcb.ca.gov/rwqcb2>

- For creeks and tributaries that drain to the ocean in Sonoma County and north, contact:  
North Coast Regional Water Quality Control Board  
(707) 576-2220 or <http://www.swrcb.ca.gov/rwqcb1>
- For creeks and tributaries draining to the Pacific Ocean south of San Mateo County, contact:  
Central Coast Regional Water Quality Control Board  
(805) 549-3147 or <http://www.swrcb.ca.gov/rwqcb3>

### **California Coastal Commission**

Development or activity in the coastal zone requires a Coastal Development permit. The coastal zone extends inland from approximately 500 yards in developed urban areas to five miles in undeveloped areas. “Development” includes the construction or alteration of any structure, grading, quarrying of rock, change in density or intensity of land use (including land divisions), and the removal of major vegetation. Contact your local county coastal program to see if you need a permit from them or the California Coastal Commission.

- Contact the Coastal Commission directly at (415) 904-5200 or <http://www.coastal.ca.gov/>

### **Bay Conservation and Development Commission (BCDC)**

BCDC requires a permit for work within 100 feet of waters of San Francisco Bay or for levee maintenance.

- Contact BCDC at (415) 557-8778 or <http://www.bcdc.ca.gov/>

### **Joint Aquatic Resources Permit Application (JARPA)**

The purpose of JARPA is **one** permit application form that consolidates federal, state and local permits and simplifies the permit process for applicants proposing construction, fill placement, and other development activities in or near aquatic environments and wetlands. The region covered by JARPA is the San Francisco Bay Area only.

The objectives of JARPA are to develop a single form to be submitted by applicants to the necessary permitting agencies; reduce paperwork and processing time for applicants; reduce violations by improving applicant knowledge of permit requirements; and reduce the number of permit revisions and delays due to permit sequencing.

In addition, an excellent “Guide to Creek and Wetland Project Permitting” from San Mateo County is available. Visit the website at:  
<http://www.abag.ca.gov/bayarea/sfep/projects/JARPA/JARPA.html>

### County and City Ordinances

Local cities and counties generally have regulations regarding grading, setbacks, zoning, building, horse density, discharge restrictions, stormwater runoff, odors, pests, and nuisances. Contact your city and county governments for more information.

### California Environmental Quality Act (CEQA) Review

Landowners, as well as state and local governments must comply with the California Environmental Quality Act. The main purpose of a CEQA review is to identify and prevent significant potential environmental impacts. CEQA requires the preparation of an initial study and then a Negative Declaration or an Environmental Impact Report.

Some agencies, such as the California Department of Fish and Game, will review permit applications for CEQA compliance. For large projects, cities and counties may require a CEQA review. For more information, contact your city or county planning departments or the California Department of Fish and Game.

### Permit Tips

These tips can help you with the often complex permit process.

- 1. Find out if your project is regulated or requires a permit.** If you go ahead without the proper permits or without following permit approval conditions, it will very likely cost you time, money, and goodwill.
- 2. Carefully select and design your site** to eliminate or reduce environmental impacts.
- 3. Consult early with permitting and regulatory agencies** so their concerns can be addressed. Your local planning department may be able to give you a good idea of the permitting process.
- 4. Have written descriptions and site plans available.**
- 5. Learn the rules.** Study the regulations of those agencies that must approve your project.
- 6. Pay attention to details.** Follow all the rules. Respond promptly to requests for information. Be on time for meetings. Do not cut corners.
- 7. Be flexible.** While protecting water quality and creeks is a prime responsibility of agencies, they may be willing to consider alternative project designs that still meet your needs.
- 8. Get everything in writing** to help prevent misunderstandings.
- 9. Plan time for permitting and be patient, as well as persistent.**

## 5.5 Threatened and Endangered Species

The presence of, or habitat for threatened or endangered species can influence horse keeping management decisions. It is important not to harm any “listed” species such as the California red-legged frog, Alameda whipsnake, or salmon and steelhead. Some conservation measures may provide habitat benefits.

The federal Endangered Species Act of 1973 prohibits any action that could harm, harass, or further endanger a federally designated, endangered or threatened plant or animal species or the associated critical habitat. Similarly, the California Endangered Species Act of 1984 recognizes the importance of endangered and threatened species and their habitats.

The purpose of the federal Endangered Species Act is to preserve species so depleted in numbers that they are threatened with extinction. A species may be classified for protection as “endangered” when it is in danger of extinction within the foreseeable future throughout all or a significant portion of its range. A “threatened” classification is provided for those animals and plants likely to become endangered within the foreseeable future. The Act provides a program for listed species and the ecosystems upon which they depend. The Act also mandates federal agencies to cooperate with state and local agencies to resolve water resource issues relating to endangered species.

Protecting endangered and threatened species and restoring them to a secure status in the wild is the primary objective of the endangered species programs of the US Fish and Wildlife Service and the National Marine Fisheries Service. These federal agencies also cooperate with the California Department of Fish and Game.

To find out if you might have threatened or endangered species or their habitat on your property, contact the California Department of Fish and Game. A continually refined and updated computerized inventory of the locations and condition of the state’s rarest plants, animals, and natural communities is available through the Natural Diversity Database at <http://www.dfg.ca.gov/whdab/html/cnddb.html>

You can order a text report and map of your county, general area or specific property; contact the Information Services staff at (916) 324-3812. It is helpful to know the name of the USGS 7.5’ quad map that includes your location. (See Section 1.2, Inventory and map your resources.) Reports vary in cost depending on the number of records involved.

### **US Fish and Wildlife Service**

The US Fish and Wildlife Service (USFWS) has regulatory authority to conserve, protect and restore animals and plants, and their habitat, that are in danger of extinction. If endangered species are affected by activities, the work must be in compliance with USFWS regulations. Information is available on their website: <http://endangered.fws.gov/>

**National Marine Fisheries Service**

The National Marine Fisheries Service (NMFS) regulates the recovery of anadromous (ocean-going) species listed under the Endangered Species Act, such as salmon (*coho or silver*, and *Chinook or king*) and steelhead. NMFS is a part of the National Oceanic and Atmospheric Administration (NOAA), and provides expertise in the area of fish passage and fisheries restoration. NMFS identifies issues to protect, conserve and restore habitats vital to self-sustaining populations of salmonids in California. The agency operates under the authority of the Clean Water Act, California water rights, and authorities that influence adequate water for fish, Endangered Species Act, National Environmental Policy Act, and the Fish & Wildlife Coordination Act. For endangered species consultation or assistance to landowners for fisheries restoration efforts, call the National Marine Fisheries Service in Santa Rosa: (707) 575-6050, or visit their website at: <http://swr.nmfs.noaa.gov/sro.htm>

## 5.6 Photographic Monitoring

Photographic monitoring is a simple and convenient method for documenting improvements you have made to your horse facility. Photographs can be kept with your *Conservation Plan*.

Take photographs of specific areas that are addressed in your Conservation Plan to document:

- Before and after conditions to show the short- and long-term effectiveness of conservation measures.
- Changes over time in the condition of natural resources and human-made features.
- Impacts of major events, fires, floods, landslides, etc.
- Sources of pollutants (e.g., manure or chemicals) and how they are transported by stormwater runoff or contained.
- Special management areas (such as creek habitat or oak woodlands).

Take photographs from the same permanent photo points such as a fence post or tree (or create a marker with a wood or steel post). You can return to these exact points at the same time of the year to document changes over time. You may want to take photographs annually or several times per year. For example, you may take photos to correspond with the winter rains (to show runoff patterns) and also during the summer to give a contrasting view. Be sure to record the date of the photograph.

Landscape photographs can show an overview of an area, and close-up photographs can be used to show specific characteristics of an area such as soil surface or plant cover. When taking landscape photographs, always include a permanent identifiable feature in the background such as a building, tree, fence, or rock outcrop. Anticipate possible view obstructions such as tree growth, additions of barns, etc.

For specific details on photographic monitoring, review the *Photographic Monitoring for Equestrian Facilities* fact sheet produced by the Council of Bay Area RCDs. Call your local RCD or the Council of Bay Area RCDs at (707) 794-1242, ext. 121 for a copy.

## 5.7 Water Quality Monitoring

Testing your surface water will help maintain a healthy environment for horses, fish and aquatic life, and human use. With inexpensive equipment and a little training, horse owners can monitor the quality of water on their property. This section presents an overview of monitoring.<sup>15</sup> For complete information on setting up your own monitoring program and obtaining test kits, contact your local RCD or the Council of Bay Area RCDs for a horse owners monitoring information packet.<sup>16</sup>

### Water Quality Variables

The following is a description of the water quality variables and their measurements that are commonly tested by agricultural landowners and regulatory agencies.

**Ammonia.** Ammonia results from decomposition of manure and other organic debris by microbes, and is toxic to fish and aquatic invertebrates. Total ammonia is composed of two forms: ionized ammonia ( $\text{NH}_4^+$ ), and un-ionized ammonia ( $\text{NH}_3$ ). Of these two forms, the un-ionized  $\text{NH}_3$  is far more toxic. The percent of total ammonia in the harmful un-ionized form increases with higher water temperatures and pH values. Un-ionized ammonia can be lethal at concentrations of 0.025 parts per million (ppm.) Higher levels of ammonia are toxic to fish and other organisms. Ammonia is naturally produced by fish and is excreted primarily through their gills. Ammonia excretion is reduced if there are high ammonia levels in surrounding waters, causing high blood ammonia levels in fish. Fish respond to this increase in blood ammonia by reduced feeding that slows metabolic ammonia production. High blood ammonia levels increase a fish's need for oxygen, while at the same time reducing the ability of the fish's blood to transport oxygen. High ammonia levels can damage gills and ultimately kill fish.

Total ammonia can be measured with an electronic ammonia probe or colorimetric kit. Colorimetric kits are inexpensive and relatively accurate. They rely on chemical reactions in which chemicals bind, and then react with ammonia to form a colored product. The intensity of the color then gives a relative indication of the amount of ammonia present.

**Conductivity.** Conductivity is simply a measure of the capacity of water to transmit an electrical current. Conductivity is useful in detecting pollution from livestock urine due to the high concentration of salts in urine, and the fact that the salts persist much longer than ammonia. High salt concentrations in sur-

---

<sup>15</sup> This information was drawn from the *Water Quality Variables and Water Testing for Rural Landowners* fact sheets prepared by the Marin Coastal Watershed Enhancement Project. 1995.

<sup>16</sup> *Simply the Facts on Animal Waste and Water Monitoring*. Fact sheet series. USDA Natural Resources Conservation Service and AmeriCorps. 1995.

rounding waters disrupt the balance of salts in a fish's blood. This causes stress, and for prolonged periods can kill fish. Conductivity is measured in micromhos per centimeter or  $\mu\text{mhos/cm}$ .

**pH.** pH is a measure of the hydrogen ion concentration and ranges in value for 0 to 14. A value of 7 is referred to as neutral, while values below 7 are called acidic, and above 7 are said to be basic or alkaline. The pH of water is influenced by water source, underlying soil, effluent discharges from agricultural, industrial, and urban sources, algae, and microbial activity. The pH of water is important because it influences the amount of total ammonia that is in the most toxic un-ionized ( $\text{NH}_3$ ) form, as well as affecting a variety of chemical reactions and biological functions. High pH values increase ammonia toxicity because a greater percentage of the total ammonia is in the un-ionized form. Electronic meters, small battery operated pH pens, or a litmus paper which changes color according to different pH values can be used to measure pH.

**Temperature.** Temperature is important because it directly affects animals and also influences the physical characteristics of water and pollutants such as ammonia. Extreme temperatures have harmful effects on animal metabolism, feeding, growth, disease resistance, and reproduction. Cool water contains higher levels of dissolved oxygen than warmer water and has lower levels of toxic un-ionized ammonia. Temperature is measured with electronic and mercury thermometers. The optimum water temperature for steelhead is approximately 55-60° F, well below the summer temperature of many local streams.

**Dissolved oxygen.** This is often referred to by the initials DO, and is a measure of the oxygen that is dissolved in water. DO is critical for all aquatic life, just like oxygen in air is essential to humans and other terrestrial organisms. Because DO makes up a very small percentage of water, changes as seemingly minor as 1 part per million (ppm) can have a large impact on aquatic life. At a water temperature of 50° F, DO at saturation would typically be 11 ppm. When water temperature rises to 80° F, DO can drop dramatically to 8.0 ppm, a 27% decrease. DO can be measured with a colorimetric test kit or an oxygen probe.

**Water flow rate.** It is important to note water flow rate when monitoring because it influences the concentration of pollutants. Knowing whether water quality problems were detected following a rainstorm when flows are high, versus a drier period, can help to identify the source and magnitude of the problem. If pollutants are found during high flows when they are apt to be diluted, it is possible that pollutants will be more concentrated when flows are lower. Problems that are detected at low flows, when runoff from surrounding areas is also low, probably come from a source near to the stream. Water flow can be estimated as low, medium, or high. A more accurate determination can be made by calculating the volume of a given stream area and then measuring the flow rate through this pre-measured area.

**Sediment.** Excessive sediment from erosion can fill in gravel beds used by salmon and steelhead for spawning. This can make the beds unsuitable for spawning or smother developing eggs in the gravel. Sediment can also fill in deep pools that remain cool in the summer and provide habitat for young fish. Sediment can be measured by allowing a water sample to stand and measuring the amount of sediment that settles. Imhoff sediment cones or tall glass jars can be used for this purpose.

## Where and When to Test

Testing at your upstream and downstream property boundaries (where water enters and leaves your property) will tell you how clean the water flowing into your property is, and whether or not conditions on your property are contributing to water quality problems. If water is more polluted at the downstream boundary, test water upstream on your property to find pollution sources. Check for problems near areas of high-use, manure storage, field applications of manure, and *horse wash areas*. Also check tributary drainages to see if problems are coming from upslope areas. By actively monitoring the water quality conditions on the property, the monitoring results could be a helpful tool in your defense if a dispute arises.

Tests should be done at least monthly throughout the year (in areas with year round water) and more often in the rainy season. Because runoff from early rains can have high concentrations of animal waste that has accumulated over the summer, it is important to test after the first storm that causes runoff. Test immediately after significant storm events (1 inch or more of rain in 24 hours) as these storms pose big threats to water quality. It may be helpful to have a rain gauge at the facility to track the amount of rain in each major storm as well as the total annual rainfall.

Keep records to provide a comparison of water quality over the years. You should be able to detect changes that show the effectiveness of your conservation measures.

## 5.8 Guidelines for Managing Residual Dry Matter (RDM)

Understanding the life cycle of pasture plants will help you to keep them productive. Annual grasses and forbs (broad-leaf plants) dominate dryland (unirrigated) pastures in the San Francisco Bay Area. Annual plants grow from seed each year. Because their seeds germinate with the onset of fall and winter rains, weather has a great impact on the early growth of annual plants. The growth period continues through the winter and early spring.

In the late spring and summer, annual plants mature and die. The residue or dry plant material that is left on the ground not only provides a seed source for the following year's plants, it also protects the soil from erosion and decreases the potential for manure to be transported downstream. Managing dryland pastures dominated by annual plants is really about managing this residue or "*residual dry matter*" (RDM).

Managing RDM in pastures dominated by annual plants is the most effective way to improve the condition of the soil surface, increase its water holding capacity, increase plant productivity, and minimize the invasion of weedy plants. Mapping of pastures to show areas with varying amounts of *residual dry matter* will help determine where pasture distribution can be improved.

The amount of RDM left in horse pastures before the start of the winter rains to protect the soil will vary according to soil type, slope, and climate. For example, areas with erosive soils or steep hills require more RDM than flat, stable soil. The following guidelines represent a range of minimum levels for annual grassland sites in the San Francisco Bay Area.

RDM monitoring can involve actual measurement of plant residues or visually estimating plant residues based on appearance.<sup>17</sup> Clipping and weighing involves measuring patches or "quadrats" of plant residue and can be a time consuming method. Your measurements will be more accurate if you take more quadrat samples.

Minimum Recommended Residual Dry Matter (RDM) <sup>18</sup> to Protect Soil and Water Resources in the San Francisco Bay Area		
	Flat to Gentle Slopes (less than 30% slope) RDM	Steep Slopes (over 30% slope) RDM
San Francisco Bay Area	800 lb/ac	1000 lb/ac

<sup>17</sup> This information is drawn from the fact sheet *Vegetation Monitoring* produced by the Marin Coastal Watershed Enhancement Project.

<sup>18</sup> Wildlands Solutions Field Guide Series. 1998. *Residual Dry Matter (RDM) Monitoring Photo-Guide*.

Visual estimation can be done using the following descriptions:

- High RDM – Little or no patchy appearance. Unused plant matter averages three or more inches in height and small objects are hidden. Light grazing results in high RDM.
- Medium RDM – Patchy appearance with an average of 2 inches of unused plant matter and little bare soil. Small objects will not show at a distance of 20 feet or more.
- Low RDM – Less than two inches of unused plant matter. Small objects and areas of bare soil are visible at 20 feet or more. Heavy grazing results in low RDM.

For more information on conducting RDM monitoring, contact your local RCD or NRCS office.

## Common Grazing Terms

**Carrying capacity.** The maximum number of horses a pasture will provide feed for, while leaving adequate vegetation for pasture regeneration and protection from soil erosion. Carrying capacity depends on the soil's fertility and potential for erosion, slope, climate, the length of the growing season, and management. Carrying capacity can vary from year to year due to weather and previous use.

**Grazing distribution.** Ideal grazing distribution results in pastures with a uniform cover of *residual dry matter* (RDM) remaining at the start of the winter rains to protect the soil surface from erosion and reduce the establishment of unwanted weeds. However, horses are selective grazers and will selectively graze immature forage, which results in spot grazing. Areas with short, new growth are repeatedly grazed while other areas mature past the point of being desirable forage. As desirable plants are grazed out, weedy species tend to increase. Good grazing distribution prevents horses from too heavily "overgrazing" their favorite grass. Even with the proper stocking rate, grazing distribution can be a problem in larger pastures.

**Residual Dry Matter (RDM).** This is the amount of plant residue left in the field after grazing, expressed in pounds per acre.

**Rotation grazing.** Moving horses to a fresh pasture after the old pasture has been grazed to the desired level.

**Season of Use.** Optimal pasture productivity depends on controlling "when" and "how long" horses have access to pasture. Year-round access to pastures may not be an option. When to have horses on pasture depends on soil moisture and amount of forage available. Horses can compact wet soil, making it harder for grasses to grow and can readily trample wet turf.

## 5.9 Alternatives to Pesticides<sup>19</sup>

For most horse owners, insect control is a prime concern. Flies can carry diseases and cause problems such as conjunctivitis and wound infections. Biting flies, mosquitoes, and insects such as “no-see-ums” aggravate your horse and cause complications related to itching. Chemical fly sprays, as well as herbicides, fungicides, and other pesticides can severely impair water quality if direct application, airborne transport, or runoff carries the products to creeks.

Environmentally sensitive methods to reduce and manage the fly and insect population at your horse facility include reducing insect habitat, using beneficial insects, putting the local wildlife to work, and setting traps. Using these controls will help you reduce the use of insecticides. Plus, having fewer flies and chemicals will make your place healthier for you and your horses, and more pleasing for your neighbors.

### What is Integrated Pest Management?

Integrated pest management is an ecosystem-based strategy that focuses on long-term prevention of pests or their damage through a combination of techniques such as biological control, habitat manipulation, and modification of management measures. Pesticides are used only after monitoring indicates they are needed according to established guidelines, and treatments are made with the goal of removing only the target organism. Pest control materials are selected and applied in a manner that minimizes risks to human health, beneficial and non-target organisms, and the environment.

Check with University of California Cooperative Extension or your county agriculture commissioner for more information on alternatives to control undesirable plants or insects.

### Ways to reduce pesticide use

#### Address the source of the fly problem first

The crux of effective fly control is to identify and eliminate breeding areas. Virtually any situation that combines moisture and organic material (e.g., mud, manure, or soiled bedding) can support fly maggot development. Mosquito eggs only hatch in water. Contact your local mosquito abatement or vector control district if you have mosquito problems. Practicing sound manure management and having



*Use a fly mask to reduce the need for chemical fly control. Also, help control flies by eliminating breeding areas such as mud, manure, or soiled bedding. Managing manure and improving drainage can help create a better environment for horses.*

<sup>19</sup> Adapted from *Fight Nature with Nature: Environmentally Friendly Insect Control for Horse Farms* by Alayne Blicke, Horses for Clean Water. 1999.

proper drainage will greatly reduce the amount of mud and water insects in which flies can breed.

### **Encourage beneficial insects, birds, and bats**

- **Good bugs.** “Fly parasites” are gnat-sized, nocturnal wasps, which lay their eggs in the developing pupae of flies, thereby reducing or nearly eliminating the fly population. They do not harm humans or animals in any way—in fact, you won’t even notice their presence. To find the parasites, try local garden stores, check the ads in horse publications, and look in farm supply catalogs. Discuss with the supplier the number of fly parasites and the frequency of release your conditions require to optimize effectiveness.
- **Helpful birds.** Encourage insect-eating birds to move into your barn area as an excellent means to reduce the flying insect population. Swallows are voracious insect eaters consuming up to 6,000 insects per day! Cliff swallows build mud nests when they arrive in spring. Help them along by providing puddles of water where they can gather mud. Screen off areas (using 1/2 inch or smaller wire mesh) where you don’t want them. Nest boxes for bluebirds, tree swallows and violet-green swallows can be built or purchased. Nest box plans are available from the Natural Resources Conservation Service. Consult your local Audubon Society, birding organization, or wild bird store for more information. Also see *Steps to Improving Songbird Habitat at your Horse Ranch* in Section 5.10 of the Resources Directory.
- **Bat friends.** Bats eat nocturnal flying insects such as mosquitoes. One bat can eat up to 600 mosquitoes per hour, more than 5,000 per night. They also eat other agricultural pests. Bat houses can be placed on a barn, pole, tree, or the side of a house. The best habitat for bats is within a half mile of a stream, pond, or wetland. Bat houses need to be placed by early April, and it can take up to two years for a bat colony to find the house. Bat houses can be built or ordered through garden catalogs. Bat Conservation International is a good source for more information.

Be sure to consult your veterinarian for recommendations on vaccinating your horses against rabies. Bat rabies accounts for approximately one human death per year in the United States.

### **Trap insects**

Several types of simple insect traps can be useful for reducing the flying insect population. Flypaper is one of the easiest and cheapest. Pheromone traps are simple jars with one-way lids. A small amount of pheromone solution, a natural substance that attracts flies, is placed in the jar. The flies (and yellow jackets!) buzz into the jar, can’t get out, and die. Traps are sold by different companies under various names. Check farm and horse supply outlets.

You can make your own bait jars to trap flies very cheaply and easily. Take an old mayonnaise or similarly sized jar and punch several holes through the lid. Put in

a few pieces of raw hamburger or fish and about an inch of water. Flies make their way into the jar and drown. This method can be smelly and attract other unwanted pests, as well as your dog!

### **Be cautious when using pesticides**

No matter how much fly control you use, there are still likely to be some flies around, especially on hot, sunny days. Regular application of pesticides may still be necessary to control insects that bother horses, especially for those horses hypersensitive to insect bites. If you use chemicals:

- Consult your veterinarian for the type of fly spray recommended and the frequency of application.
- Read and follow instructions carefully to be sure you protect yourself, your horses, and the environment.
- Cover feed *troughs*, mangers, and water devices to prevent contamination of feed and water. Do not spray inside feed storage rooms.
- Do not apply pesticides near creeks, rivers, lakes, ponds, or other aquatic areas.
- Watch weather conditions to avoid drift of chemical sprays onto other properties.

## 5.10 Improving Songbird Habitat on Your Horse Ranch



*Fact sheet prepared by Point Reyes Bird Observatory  
California Partners in Flight and the Riparian Habitat Joint Venture*

Equestrians are people who love horses and enjoy being with them outdoors. Many stables or breeding facilities are located on large sections of land, often including creeks or sections of wooded habitat that could sustain a healthy population of native birds. These guidelines are beneficial for both birds and the horse owner, whether you have one horse or an entire stable.

The songbird-breeding season lasts from late March through August in California. During this period, songbirds are constantly busy building nests and raising their young. It is during this period that they are most vulnerable to predators, changes in vegetation and food supply. There are many steps that can be taken to make this time a productive one for birds on your land. We'd like to encourage horse and wildlife lovers to turn their stables into a productive place for bird populations. By providing habitat – especially natural nest sites and foraging areas – you can play an important role in ensuring healthy bird populations for the future. In turn, riding around your property will be more enjoyable with healthy habitat and birds to look at.

### Preserve and restore existing “on ranch” native habitat

- The best way to begin helping birds is by leaving and enhancing the native vegetation on and around your horse ranch. Native vegetation provides the best nest cover and feeding sites for breeding birds. The following are steps you can take to enhance the existing native habitat on your horse ranch:
- **Fence horses and livestock out of creeks, wetlands, lakes and ponds**—this will increase the native vegetation around creeks and streams which is crucial for breeding songbirds as well as to help reduce muddy areas around water sources that can cause horse ailments such as thrush, mud fever and scratches. Cost effective watering sources are available to supply your horses with water on dry ground.
  - **Build water crossings** across creeks to enable horses to move between pastures without damaging the creek or other drainages.
  - **Line pastures and driveways** with native trees, shrubs, and grasses to create habitat for birds. This will also eliminate wind, help control weeds toxic to horses such as star thistle, and provide shade for horses. Make sure these areas are *fenced* to prevent horses from entering these areas. When possible, connect these rows to existing habitat on creeks or other natural areas on your ranch.
  - **Avoid non-native** trees and shrubs such as eucalyptus, tamarisk and broom, when designing your jumping, cross-country, and trail courses. Contact your native plant society for suggestions on native plants and shrubs appropriate to your area. For a list of native plant societies see PRBO's website at <http://www.prbo.org/>
  - **Leave dead trees or dead limbs** for cavity nesting species such as woodpeckers, bluebirds, nuthatches, and titmice.
  - **Provide nest material** such as grass clippings, leaf litter, and horsehair.

### Manage Your Waste!

Runoff from manure piles, wash racks, and grooming areas can pollute the creeks and seasonal drainages on your ranch. This affects the birds and other wildlife that breed in streamside areas. The following are ways to safely manage your waste:

- **Keep manure** piles far away from creeks, ponds, lakes, and wetlands.
- **Reduce manure** piles by either *composting manure* or arranging for removal by local farmers, mushroom growers or other interested parties.
- **Make sure** wash rack drains are not emptying into creeks or other drainages.
- **Use non-toxic** and biodegradable products when grooming and bathing your horse.

### Control Predators and Pests!

Eliminate stable pests such as mice, rats, and non-native birds such as house sparrows and starlings.

- **Use traps**, not cats, to control rodents in hay barns and tack rooms. Cats kill an estimated 4.4 million birds a day in North America. For more information see the Cats Indoors Program! at <http://www.audubon.org/bird/cat/index.html>
- **Keep grain** in sealed containers in designated feed rooms, and clean up spilled grain immediately to keep from attracting rodents.
- **Feed horses in feeders** and remove uneaten hay daily. This not only prevents grain and hay from attracting rodents and flocks of non-native birds to stalls and paddocks, it prevents mud accumulation in winter and can help prevent your horse from ingesting mud or dirt which can lead to sand colic.

Control introduced (non-native) predators:

- **Keep cats indoors**, especially during the songbird breeding season when vulnerable young birds are just out of the nest. Bells on the collar are not enough. Control mice and rodent populations by the methods suggested above, eliminating the need for stable cats.
- **Reduce feral cat** populations, don't feed strays, and spay and neuter all house cats.
- **Eliminate sources** of food such as open garbage, compost, and outdoor pet dishes that attract raccoons, opossums, jays, and stray cats.

### Swallows

Barn and Cliff Swallows are insectivorous birds that like to nest under the eaves of roofs on barns and houses. Colonies of swallows provide the invaluable service of free, natural insect control. The large number of flies associated with stables is one of the reasons swallows choose to breed on so many barns. However, if you prefer not to have swallows, there are a few things that you can do to safely discourage them from nesting on your property.

- Discourage swallows from nesting on your house or barn **before** they get their nest started by eliminating space under eaves. You can place boards or a fine wire mesh (1/2 inch or smaller) at an angle to close up the space under roof overhangs.
- Designate one section of your barn or house to allow swallows to nest.
- Don't use Tanglefoot or other sticky substances to discourage the birds as it harms their feet and feathers.

## 5.11 Helpful Publications and References

### Equine Facilities Assistance Program Fact Sheets

The following fact sheets were developed as part of the Equine Facilities Assistance Program. To obtain copies, contact the Council of Bay Area Resource Conservation Districts at (707) 794-1242, ext. 121, or your local Resource Conservation District.

- Number 1: Program Background*
- Number 2: Composting Horse Manure*
- Number 3: Conservation Measures to Reduce Non-point Source Pollution at Horse Facilities*
- Number 4: Photographic Monitoring for Equestrian Facilities*
- Number 5: Horse Paddocks: Designed and Managed to Protect Water Quality*
- Number 6: Controlling Yellow Starthistle*
- Number 7: Dryland Pasture for Horses*
- Number 8: Portable Backyard Garden*
- Number 9: Horse Manure Management*
- Number 10: Stormwater Runoff Management at High-use Areas*

*Horse Owners Guide to Water Quality Protection* brochure is also available.

### Erosion and sediment control

- Erosion and Sediment Control Field Manual*. 1999. San Francisco Bay Regional Water Quality Control Board. 1999. Contact: Friends of the San Francisco Estuary at (510) 622-2419.
- Groundwork: A Handbook for Erosion Control in North Coastal California*. 1987. Liza Prunuske. Marin County Resource Conservation District. Contact Marin County RCD at (415) 663-1170 or: [marinrcd@svn.net](mailto:marinrcd@svn.net)
- Principles & Practices of Erosion Control*. Santa Cruz County Resource Conservation District. Contact: Santa Cruz RCD at (831) 464-2950.
- Repairing Streambank Erosion*. 1997. Brochure prepared by Prunuske Chatham, Inc. for Marin County Stormwater Pollution Prevention Program.
- Start at the Source: Design Guidance Manual for Stormwater Quality Protection*. 1997. Tom Richmond and Associates. Bay Area Stormwater Management Agencies Association (BASMAA). New York: Forbes Custom Publishing.

### Water resources/watersheds/riparian environments

- Creek Care: A Guide for Urban Marin Residents*. Martha Neuman. Marin County Stormwater Pollution Prevention Program. Contact MCSTOPP at (415) 485-3363.
- Guide to Stream Project Permitting for the State of California*. California Association of Resource Conservation Districts. Call (916) 447-7237 or contact <http://www.carcd.org/>

*Riparian Buffers for Agricultural Land*. 1997. Mike Dosskey, et al. Iowa State University. Department of Forestry. Agroforestry Notes AF Note-3.  
*Stewards of our Streams; Riparian Buffer Systems*. 1997. Richard C. Schultz, et al. Iowa State University. University Extension Pm-1626a.

## Water quality

California Rangelands website at UC Davis. Fact sheets on water quality and more. Search the web using keywords: California Rangeland Watershed Program Fact Sheets.

*Simply the Facts on Animal Waste and Water Monitoring (for Landowners, Farmers, & General Public)*. A series of fact sheets from USDA Natural Resources Conservation Service and AmeriCorps. Contact the Council of Bay Area RCDs at (707) 794-1242, ext. 121.

## Manure and waste management

California Materials Exchange (CalMAX): <http://www.ciwmb.ca.gov/calmax>  
*Good Horse Keeping—Managing Manure to Protect the Environment* (video). 1999.

King's Mark Resource Conservation & Development Area, Connecticut.  
 Horse Environmental Awareness Program. Cost is \$10. Call (203) 284-3663.

*Horse Wastes and Composting*. Adda Quinn. EnviroHorse. Contact:  
<http://www.californiastatehorsemen.com/envirohorse.htm> or email at  
[envirohorse@yahoo.com](mailto:envirohorse@yahoo.com)

*How to Compost and Use Horse Manure*. Alayne Blickle. Horses for Clean Water  
 Tipsheet. Contact <http://members.aol.com/arblickle/>

*Livestock Waste Facilities Handbook*. 1993. Midwest Plan Service. MWPS-18.  
 Iowa State University.

*Manure and Waste Management for the Horseowner*. 1983. Division of Agricultural Sciences,  
 University of California. Leaflet 21397. Call (800) 994-8849.

*On-Farm Composting Handbook*. 1992. New York: Northeast Regional Agricultural  
 Engineering Service, Cooperative Extension. NRAES-54. (152 Riley-  
 Robb Hall Ithaca, NY 14853-5701. Call (607) 255-7654 or email  
[nraes@cornell.edu](mailto:nraes@cornell.edu)

*Recommended Best Management Practices for Dairies and Other Animal Facility  
 Operations in Region I*. 2000. California Regional Water Quality Control  
 Board. North Coast Region.

*The Rodale Book of Composting*. 1992. Deborah Martin and Grace Gershuny,  
 editors. New York: Rodale Press.

## Equine facilities management and site planning

*Home\*A\*Syst, An Environmental Risk-Assessment Guide for the Home*. 1997. New  
 York: Northeast Regional Agricultural Engineering Service. NRAES-87. Call  
 (607) 255-7654 or email: [nraes@cornell.edu](mailto:nraes@cornell.edu)

- Horse Handbook, Housing and Equipment.* 1971. Midwest Plan Service. Iowa State University. MWPS-15.
- Horse Industry Handbook, A Guide to Equine Care and Management.* 1993. Kentucky: American Youth Horse Council. Call (606) 226-6011.
- Horse Management Program* (video). 1998. Resource Conservation District of the Santa Monica Mountains. 122 North Topanga Canyon Blvd, Topanga CA 90290. Call: (310) 455-1030. Cost is \$5.
- Horsekeeping on a Small Acreage, Facilities Design and Management.* 1990. Cherry Hill. Vermont: Storey Books.
- Pollution Control for Horse Stables and Backyard Livestock.* 1994. Terrene Institute.
- San Diego County Association of Resource Conservation Districts.* 1990. Backyard Ranches, A Horse Management Program for San Diego County.
- Shelter and Care of the Backyard Horse.* 1983. University of California. Division of Agricultural Sciences. Leaflet 21337. Call (800) 994-8849.
- Small Ranch Manual, A Guide to Management for Green Pastures and Clean Water.* 1995. University of Nevada Cooperative Extension. University of Nevada Reno.
- Stable and Horse Management in the Santa Monica Mountains, A Manual on Best Management Practices for the Reduction of Non-point Source Pollution.* 1999. Resource Conservation District of the Santa Monica Mountains.
- Tips on Land and Water Management for Small Farms and Livestock Owners in Western Washington.* 1998. King Conservation District. Washington. For more information, call: (206) 764-3410, email: [district@kingcd.org](mailto:district@kingcd.org) or visit: [www.kingcd.org](http://www.kingcd.org)
- Workbook: Water Quality Planning Course for Equine Facilities.* 1999. Alameda County Resource Conservation District. Contact ACRCDD at (925) 371-0154.

## Pasture management

- Establishing and Managing Irrigated Pasture for Horses.* 1982. Division of Agricultural Sciences, University of California, Leaflet 21164. Call (800) 994-8849.
- How Grass Grows – The “REST” of the Story.* USDA Natural Resources Conservation Service.
- Management of Small Pastures.* 1980. Division of Agricultural Sciences, University of California, Leaflet 2906. Call (800) 994-8849.
- National Range and Pasture Handbook.* 1997. USDA Natural Resources Conservation Service. Website: <http://www.glti.nrcs.usda.gov/technical/publications/nrph.html>
- Residual Dry Matter Monitoring Photo-Guide.* 1998. Wildland Solutions, 234 Park St., Clyde, CA 94520.

## Roads and trails

- Does Horse Manure Pose A Significant Risk to Human Health?* Adda Quinn. Email: [envirohorse@yahoo.com](mailto:envirohorse@yahoo.com) or <http://www.californiastatehorsemen.com/envirohorse.htm>

*Handbook for Forest and Ranch Roads: A guide for planning, designing, constructing, reconstructing, maintaining, and closing wildland roads.* 1994. William Weaver, PhD., and Danny Hagans for the Mendocino County Resource Conservation District. This \$20 book is available from the Mendocino County RCD at (707) 468-9223.

## **Integrated pest management**

Bat Conservation International. Contact: <http://www.batcon.org/>

*Fight Nature with Nature: Environmentally Friendly Insect Control for Horse Farms.* 1999. Alayne Blickle. Washington: Horses for Clean Water. Contact: <http://members.aol.com/arblickle/>

*Integrated Management of Pest Flies on Horse Ranches.* 1981. University of California. Division of Agricultural Sciences. Leaflet 2335. Call (800) 994-8849.

North American Bluebird Society. For plans for bluebird nest boxes, contact: <http://www.nabluebirdsociety.org/>

## Glossary

- Aquatic life.** Plants or animals that require water and associated riparian habitat to live.
- Clean water.** Rainfall that has not come into contact with a pollutant such as horse manure, or picked up pollutants such as sediment.
- Concentrated water.** Water flow that has increased in volume and velocity due to either natural drainage or human-made diversion of drainage.
- Conservation measure.** Any management practice, activity, or structure to prevent or reduce water pollution and/or enhance natural resources.
- Conservation plan.** A set of decisions for a long-term management strategy to protect and enhance natural resources for a property. These decisions are recorded in a conservation plan, which documents decisions made and describes the schedule of operations and activities needed to solve identified problems. Maintenance and monitoring are also included.
- Polluted water.** Water that has become adversely affected physically, chemically, or biologically by chemicals or other additives, such as manure or sediment.
- Contaminant.** The impairment of water quality by waste to a degree that creates a hazard to public health through the spread of disease.
- Creek.** A watercourse smaller than a river. Used in this guide to cover all sizes and types of fresh water bodies such as rivers and streams. May or may not have year-round surface flow.
- Diversion.** A channel or structure to divert water at a non-erosive velocity to sites where it can be used or discharged at an erosion resistant outlet.
- Downslope.** Downhill.
- Drainage.** Movement of water downward through the soil or across land.
- Erosion.** The wearing away of land surface by wind or water. Occurs naturally from weather or runoff, but can be intensified or accelerated by human activity.
- Ground water.** Water stored underground that fills the spaces between soil particles or rock fractures. (Also see near-surface ground water.)
- Horse facility.** In this guide, the areas used in caring for horses (i.e., barns, paddocks, turnouts, arenas, etc.) whether for a single backyard horse or a larger boarding operation.
- Horse waste.** Manure, urine, used bedding, and spoiled hay.
- Impervious/ impermeable surface.** Any surface that cannot be easily penetrated by water, such as roofs, compacted soils, and paved areas.
- Leachate.** Liquid which has come into contact with or percolated through manure being stockpiled or stored; contains dissolved or suspended particles and nutrients.
- Manure.** In this guide, manure includes both the feces and urine from horses.
- Near-surface ground water.** Ground water just below the soil surface and above the normal water table due to water-saturated soils. As well as slowly moving downward, near-surface ground water generally flows in the same direction as the surface runoff above until it reemerges to the surface at a creek.
- Nonpoint source pollution.** The diffuse discharge of pollutants that can occur

over an extensive area, such as a pasture, as opposed to point source pollution that can be pinpointed to a specific location, such as an outlet at a sewage treatment plant. Nonpoint source pollution occurs as water from rainfall or snowmelt moves over and through the ground, it picks up and transports natural and human-created pollutants, eventually depositing them into surface and ground water.

**Nutrient.** The portion of any element or compound that can be readily absorbed and assimilated to nourish plants; examples include nitrogen and phosphorus.

Even in small amounts these same nutrients can have a harmful effect on water quality. Horse manure can degrade water quality because it is rich in nutrients.

**Organic material.** Substance derived from living organisms (plants or animals).

**Outlet.** The area where water is discharged from a downspout, culvert, pipe, channel, or ditch.

**Overgrazing.** Severe grazing that causes a decrease in plant cover and correspondingly causes plant roots to die back.

**Pollutant.** The presence of a substance in such quantities that when it reaches a body of water, soil, or air, it is degrading in effect that it impairs their usefulness or renders them offensive.

**Pool.** A depression in the streambed used by aquatic life.

**Residual Dry Matter (RDM).** The amount of plant residue, expressed in pounds per acre, left in the field after being grazed.

**Riffle.** Sections of a stream with moderate turbulence caused by water flowing over rocks.

**Rill erosion.** Small, well-defined channels several inches deep that form when loose particles of soil and rock are transported downhill by water.

**Riparian area.** The area immediately adjacent to the banks of a creek, lake, or other waterbody. The riparian area is distinctly different from surrounding lands because of unique soil and vegetation characteristics that are strongly influenced by free or unbound water in the soil.

**Riprap.** Heavy rock used to protect soil from the erosive action of fast-moving water. Minimum size is typically 12 inches x 12 inches x 6 inches with a bulk specific gravity of 2.5 or greater.

**Rolling dip.** A shallow, rounded dip in the road to provide effective drainage where surface runoff is directed in the dip to the side of the road.

**Runoff.** Water from rain or other sources (for example, from a hose or a *horse wash area*) that does not infiltrate into the ground but runs over the land surface and into creeks.

**Seasonal drainages.** Small, natural or human created swales, depressions, or drainages that carry water only after a rainfall.

**Sediment.** The soil material, both mineral and organic, that is suspended, is being transported, or has been moved from its site of origin by erosion and has come to rest on the land surface or at the bottom of creeks, ditches, reservoirs, or bays.

**Sheet flow.** A shallow flow of water that is spread uniformly over the land surface. Sheet flow will concentrate into rills and gullies.

**Soil type.** Soil is unconsolidated mineral and organic surface material with

specific physical, chemical, and biological properties to support plant growth. Soil is grouped into three basic types based on particle size: clay has small particles; silt/loam has medium size particles; and sand/gravel has large particles.

**Stormwater runoff.** Clean rain water that flows over the land surface without entering the soil.

**Turnout.** A high-use area where horses are “turned out” for exercise after being confined in stalls. Turnouts can be exercise lots, small paddocks, pens, or corrals. These areas are typically bare and not managed as pastures.

**Upslope.** Uphill.

**Water quality.** Describes the chemical, biological, and physical characteristics of water. The quality of water can limit its specific use or ability to support various beneficial uses such as water supplies for municipalities, industry, agriculture, recreation, and fish and wildlife habitat.

**Watershed.** Total land area that drains into a particular creek, river system, or bay. It includes major and minor creeks, seasonal drainages, hillsides, and floodplains. Watershed boundaries are defined by the ridges that separate drainage between watersheds.

**Water table.** The underground boundary below which all spaces between soil particles are saturated with water. Water tables fluctuate throughout the year but are usually highest in early spring.

**Wetlands.** Areas that are inundated or saturated by surface or ground water at a frequency and duration sufficient to support a prevalence of vegetation typically adapted for life in saturated soil conditions.

## Index

### A

ammonia 3, 9, 10, 27, 90, 91  
 aquatic life  
     2, 3, 7, 9, 10, 32, 44, 56, 68, 83, 90, 91, 104, 105

### B

bacteria 8, 10, 38, 39, 40  
 bats 96  
 bedding 10, 17, 23, 24, 25, 27, 29, 95, 104  
*berm* 8, 20, 31, 42, 49, 59, 62, 63  
 birds 96, 98  
 bridge 13, 44, 48

### C

*check dam* 36, 44, 48, 53, 60  
 clean water 8, 61, 104  
*compost area* 25, 26, 30, 49  
*composting manure* 25, 29, 49, 100, 101  
 concentrated water 60, 61, 104  
 conservation measure 16, 17, 19, 51, 104  
*conservation plan*  
     11, 12, 18, 23, 24, 26, 48, 89, 104  
*constructed wetland* 31, 49, 66, 72  
 construction management 46  
 contaminant 39, 104  
 conveyance 31, 49, 63, 78  
 creeks 2, 3, 37, 67, 100, 104  
*cross-fencing. See fencing*  
*culvert* 42, 43, 44, 48, 59, 66, 82

### D

discharge area 66  
 ditch 7, 20, 41, 43, 44, 55, 63, 82  
*diversion* 7, 20, 23, 49, 62, 63, 82, 104  
*downspout* 16, 20, 49, 62, 63, 82  
 drainage 46, 104  
 drainfield 40  
*drop inlet* 48, 49, 59, 61, 64, 65  
 dust 22, 24, 30, 43, 68

### E

emergency measures 17, 58  
 endangered species 87  
*energy dissipater* 20, 41, 42, 43, 49, 62, 66, 82

erosion 2, 5, 6, 21, 22, 36, 37, 52, 104  
 erosion control 6, 7, 32, 40, 46, 52, 100  
*erosion control blanket* 44, 48, 53, 59, 64

### F

*fencing* 22, 33, 36, 37, 48, 53, 68  
 fertilizer 26, 27, 28, 38, 52, 64, 70  
 filter fabric 22, 23, 43, 66  
*filter strip*  
     7, 9, 16, 20, 22, 26, 30, 31, 37, 49, 52, 63, 66, 78, 82  
 flies 29, 95, 97, 103  
 footing 7, 8, 22, 23, 82  
*ford* 44, 48

### G

grading  
     8, 17, 20, 26, 36, 40, 41, 45, 46, 57, 68, 69, 70  
*grassed waterway*  
     8, 20, 31, 49, 52, 53, 63, 64, 66, 78  
 grazing 34, 36, 40, 70, 94  
*grazing distribution* 33, 48, 94  
 ground water  
     2, 4, 9, 15, 26, 27, 29, 31, 38, 39, 40, 55, 72, 104  
*gully repair* 36, 48, 53  
*gutter* 16, 20, 49, 62, 82

### H

headcut 36, 53  
 herbicides 7, 81, 95  
 high-use areas 20, 21, 37, 66, 67, 82, 100  
*horse wash area* 2, 16, 31, 37, 49, 92

### L

leachate 21, 23, 26, 27, 72, 104  
*lined waterway* 42, 49, 53, 63, 64, 65, 66

### M

manure 9, 25, 27, 49, 82, 100, 101, 104  
*manure application* 26, 49, 72  
 manure management 16, 23, 24, 29, 95  
*manure storage area*  
     9, 16, 20, 27, 30, 37, 49, 62, 63, 82  
 monitoring  
     17, 18, 26, 38, 61, 89, 90, 93, 100, 101  
*mulch*  
     16, 35, 36, 44, 45, 48, 52, 53, 59, 69, 70, 79, 80

**N**

near-surface ground water 4, 15, 24, 104  
 nitrogen 5, 9, 10, 26, 27, 29  
*nose pump* 37  
 nutrient management 26  
 nutrients  
     3, 5, 9, 10, 26, 27, 29, 38, 40, 52, 66, 67, 68,  
     69, 72, 105

**O**

odor 26, 29, 30  
 outlet 20, 42, 43, 59, 64, 66, 82, 105  
 overgrazing 33, 36, 94, 105

**P**

*paddock*  
     7, 20, 23, 24, 25, 34, 35, 49, 61, 82, 99, 100  
 pasture 7, 26, 32, 80, 82, 100, 102  
 permits 38, 45, 46, 57, 68, 72, 83, 100  
 pesticides 7, 38, 39, 70, 95  
 pests 99  
*pipeline* 70  
 pollutant 10, 20, 23, 78, 89  
 pollutants 6, 8, 37, 38, 39, 67, 72, 105.  
     *See* contaminant  
 polluted water 2, 9, 66, 104

**R**

regulations 30, 83  
*residual dry matter* 34, 48, 93, 105  
 riparian area 3, 8, 33, 37, 38, 67, 105  
*riparian buffer* 7, 37, 38, 42, 49, 67  
 road base 22, 23  
 roads 7, 40, 41, 82, 102  
 roof runoff management 20, 49, 61  
*rotation grazing* 94

**S**

*sandbag pipeline drop inlet* 48, 61  
*sandbags* 48, 59  
 scratches 23  
 seasonal drainages 44  
 sediment 2, 3, 6, 7, 9, 10, 23, 31, 38, 40, 66,  
     69, 92, 100, 105  
*sediment basin* 49, 65  
*seed* 16, 35, 36, 43, 44, 45, 48, 52, 53, 64, 69  
 seed suppliers 77  
 seeding recommendations 22, 78  
 septic systems 15, 37, 40

*silt fence* 7, 48, 61  
 site map 13, 15  
 soil survey 13, 75  
*splash pad* 49, 62  
*spring development* 34, 37, 48, 70  
*storage tank* 37, 48, 70  
 stormwater runoff 106. *See* clean water  
*straw bale check dam* 48, 60  
*straw bale sediment barrier* 7, 48, 60  
*straw bale waterbar* 48  
 stream crossing 40  
*streambank stabilization* 48, 55  
*subsurface drain* 20, 49, 62  
 surface water 66

**T**

threatened species 87  
 trails. *See* roads  
*trash rack* 43, 48, 65, 82  
*trough* 37, 48, 70  
*turnout* 7, 20, 35, 49, 106

**U**

*underground pipeline*  
     8, 37, 42, 49, 63, 64, 65, 66

**W**

wash area. *See* horse wash area  
*waste pond* 30, 31, 49, 72  
 water quality  
     1, 10, 15, 39, 46, 51, 83, 90, 95, 100, 101, 106  
 water table 3, 4, 5, 30, 31, 39, 106  
*waterbar* 42, 43, 48, 59, 82  
 watershed 2, 100, 106  
 weeds 33, 36, 52, 70, 80, 81, 82, 100  
 wells 15, 22, 25, 37, 38  
 wildlife habitat 2, 15, 38, 57, 67, 68, 71  
*willow sprigging* 49, 69, 71  
 winterization 82

# Horse Keeping:

## A Guide to Land Management for Clean Water



This is a manual for everyone who enjoys horses and is concerned with managing them in a way that protects our land and water resources. It is interesting, informative, and written so that even the layman with no prior knowledge of land management issues will be able to operate his facility in an environmentally friendly manner.

*Joel Bartlett*  
*Horseman and meteorologist*

It was a pleasure reviewing this guide, *Horse Keeping: A Guide to Land Management for Clean Water*. When someone says to me, "There's no problem with backyard horse keeping," I disagree. The Sonoma County Horse Council found in the 1999 Horse Census and Economic Survey that the majority of horses in the county are in back yards. When you have over 14,000 horses in the County, the cumulative effect could be drastic to local water bodies. The information used in the manual comes from years of dealing with the same issues concerning the dairy industry.

I work as the equestrian representative on the Animal Resource Committee, a committee that deals with manure and pollution with agriculture producers. I contact the local horse owners who receive complaints from neighbors or agencies. This allows the producer to correct any problems before any fines are levied. During the rainy season one or two situations arise each month. This manual will allow the horse owners easy access to information for improving their horse keeping practices. It is essential to have a Ranch Conservation Plan.

I teach classes at Santa Rosa Junior College titled "Water Quality and Equine Facilities Planning" and "Animal Stewardship and Water Quality." I use the Ranch Plan Workbook from the Marin Coastal Watershed Enhancement Project, and the Water Quality Planning Course for Equine Facilities, created by Alameda County Resource Conservation District. I hope to use this *Horse Keeping* manual in my classes. It is ideal to have the information located in one convenient text.

The equestrian community should be thankful that individuals involved in horse keeping were asked to review this guide and to contribute to its content.

*Michael Murphy*  
*Sonoma County Horse Council*

## Horse Keeping: A Guide to Land Management for Clean Water

This is the label for the spine of a binder.

- Obtain a 1” binder with clear windows in the front, back, and spine.
- Cut out this label, and insert it in the spine of the binder.

Place the front cover in the front of the binder, and the back cover sheet in the back of the binder.